

Dell PowerEdge C6220
Systems
Hardware Owner's
Manual

Regulatory Model B08S



Notes, Cautions, and Warnings



NOTE: A NOTE indicates important information that helps you make better user of your computer.



CAUTION: A CAUTION indicates potential damage to hardware or loss of data if instructions are not followed.



WARNING: A WARNING indicates a potential for property damage, personal injury, or death.

**Information in this publication is subject to change without notice.
© 2013 Dell Inc. All rights reserved.**

Reproduction of these materials in any manner whatsoever without the written permission of Dell Inc. is strictly forbidden.

Trademarks used in this text: Dell™, the DELL logo, and PowerEdge™ are trademarks of Dell Inc. Intel® and Intel® Xeon® are registered trademarks of Intel Corporation in the U.S. and other countries.

Other trademarks and trade names may be used in this publication to refer to either the entities claiming the marks and names or their products. Dell Inc. disclaims any proprietary interest in trademarks and trade names other than its own.

Regulatory Model B08S

August 2013

Rev. A07

Contents

1	About Your System.....	12
	Accessing System Features During Startup	12
	Front-Panel Features and Indicators.....	13
	Hard-Drive Indicator Patterns.....	18
	Service Tag	21
	Back Panel Features and Indicators	24
	System-Board Assembly Configurations.....	27
	LAN Indicator Codes	29
	Power and System Board Indicator Codes	31
	Power Supply Indicator Codes	32
	1400W	32
	1200W	33
	BMC Heart Beat LED	34
	Post Error Code.....	35
	Collecting System Event Log (SEL) for Investigation	35
	System Event Log.....	39
	Processor Error.....	39
	Memory ECC	40
	PCI-E Error	41
	IOH Core Error	42
	SB Error.....	43
	POST Start Event.....	44

POST End Event.....	44
POST Error Code Event	45
BIOS Recovery Event	46
ME Fail Event.....	47
SEL Generator ID	47
Sensor Data Record	48
Other Information You May Need	53
Fresh Air Support.....	53
Micro SD Card and SD Card Socket Location	57
2 Using the System Setup Program	58
Start Menu	58
System Setup Options at Boot.....	58
Boot Manager	59
Console Redirection	61
Enabling and Configuring Console Redirection	62
Main Menu	66
Main Screen	66
Advanced Menu	68
Power Management.....	69
Chassis Power Management.....	70
CPU Configuration	71
Prefetch Configuration	75
Memory Configuration	76
SATA Configuration	78
PCI Configuration	81

Embedded Network Devices.....	83
iSCSI Remote Boot	85
Active State Power Management Configuration.....	86
PCI Slot Configuration	87
USB Configuration	88
Security Menu	89
Server Menu.....	91
Set BMC LAN Configuration	93
Remote Access Configuration	94
Boot Menu	96
Exit Menu.....	97
Command Line Interfaces for Setup options	98
3 Installing System Components	130
Safety Instructions	130
Recommended Tools	130
Inside the System	131
Hard Drives.....	133
Removing a 3.5-inch Hard-Drive Blank	133
Installing a 3.5-inch Hard-Drive Blank	133
Removing a 2.5-inch Hard-Drive Blank	134
Installing a 2.5-inch Hard-Drive Blank	134
Removing a Hard-Drive Carrier.....	135
Installing a Hard-Drive Carrier.....	136
Removing a Hard Drive from a Hard-Drive Carrier.....	136
Installing a Hard Drive into a Hard-Drive Carrier	138

Power Supplies	138
Removing a Power Supply	139
Installing a Power Supply	140
System-Board Assembly	141
Removing a System-Board Blank Tray	141
Installing a System-Board Blank Tray	142
Removing a System-Board Assembly	142
Installing a System-Board Assembly	143
Air Baffle	144
Removing the Air Baffle	144
Installing the Air Baffle	145
Heat Sinks	145
Removing the Heat Sink	145
Installing the Heat Sink	146
Processors.....	147
Removing a Processor	147
Installing a Processor	149
Interposer Extender for 2U Node	151
Removing the Interposer Extender for 2U Node	151
Installing the Interposer Extender for 2U Node	152
Removing the Interposer Extender Tray for 2U Node	153
Installing the Interposer Extender Tray for 2U Node Tray	154
Expansion-Card Assembly and Expansion Card	154
Removing the Expansion Card for 1U Node	154
Installing the Expansion Card for 1U Node.....	157

Removing the Expansion Card for 2U Node	158
Installing the Expansion Card for 2U Node.....	162
Raid Card	164
Summary of LSI 9265-8i with RAID Battery, LSI 9210-8i HBA and LSI 9285-8e with RAID Battery.....	164
LSI 9265-8i Card	165
Removing the LSI 9265-8i Card for 1U Node.....	165
Installing the LSI 9265-8i Card for 1U Node.....	168
Cable Routing for LSI 9265-8i Card (1U Node).....	169
Removing the LSI 9265-8i Card for 2U Node.....	171
Installing the LSI 9265-8i Card for 2U Node.....	175
Cable Routing for LSI 9265-8i Card (2U Node).....	176
LSI 9265-8i RAID Battery.....	180
Removing the LSI 9265-8i raid battery Assembly.....	180
Installing the LSI 9265-8i raid Battery Assembly	181
Removing the LSI 9265-8i RAID Battery	182
Installing the LSI 9265-8i RAID Battery	183
Riser card	184
Optional Riser Cards.....	184
Removing the Riser card for 1U Node.....	186
Installing the Riser card for 1U Node	187
Cable Routing for Riser Card (1U Node)	187
Removing the Riser card for 2U Node.....	188
Installing the Riser card for 2U Node	191
Cable Routing for Riser Card (2U Node)	192

Optional Mezzanine Cards	193
Removing the LSI 2008 SAS Mezzanine Card	193
Installing the LSI 2008 SAS Mezzanine Card.....	194
Cable Routing for LSI 2008 SAS Mezzanine Card (1U Node)	195
Cable Routing for LSI 2008 SAS Mezzanine Card (2U Node)	196
Removing the 1GbE Mezzanine Card	199
Installing the 1GbE Mezzanine Card.....	201
Removing the 10GbE Mezzanine Card	202
Installing the 10GbE Mezzanine Card.....	205
Mezzanine-Card Bridge Board	206
Removing the Mezzanine-Card Bridge Board	206
Installing the Mezzanine-Card Bridge Board.....	207
System Memory	208
Memory Slot Features	208
Supported Memory Module Configuration.....	208
Removing the Memory Modules.....	210
Installing the Memory Modules	212
System Battery	214
Replacing the System Battery.....	214
System Board	216
Removing a System Board.....	216
Installing a System Board.....	217
Opening and Closing the System	218
Opening the System.....	218
Closing the System	219

Cooling Fans	220
Removing a Cooling Fan.....	220
Installing a Cooling Fan.....	222
Power Distribution Boards	223
Removing a Power Distribution Board.....	223
Installing a Power Distribution Board	228
Cable Routing for Power Distribution Board	230
Middle Planes	233
Removing the Middle Planes.....	233
Installing the Middle Planes	240
Cable Routing for Middle Plane to Direct Hard-Drive Backplane	242
Cable Routing for Middle Plane to 2.5" Hard-Drive Backplane for Expander Configuration	247
Direct Backplanes	249
Removing the Direct Backplane	249
Installing the Direct Backplane	254
2.5-inch Hard Drive Expander Configuration	256
Removing the 2.5-inch Hard Drive Backplane for Expander Configuration	256
Installing the 2.5-inch Hard Drive Backplane for Expander Configuration	264
Front Panels	265
Removing the Front Panel.....	265
Installing the Front Panel.....	267
Sensor Boards	269
Removing the Sensor Board for 3.5" Hard-Drive System.....	269

Installing the Sensor Board for 3.5" Hard-Drive System	270
Cable Routing for Sensor Board and Front Panel for 3.5" Hard Drive System	271
Removing the Sensor Board for 2.5" Hard-Drive System.....	273
Installing the Sensor Board for 2.5" Hard-Drive System.....	275
Cable Routing for Sensor Board and Front Panel for 2.5" Hard Drive System.....	276
4 Troubleshooting Your System	278
Minimum Configuration to POST	278
Safety First – For You and Your System.....	278
Installation Problems	279
Troubleshooting System Startup Failure	279
Troubleshooting External Connections	279
Troubleshooting the Video Subsystem	280
Troubleshooting a USB Device	280
Troubleshooting a Serial I/O Device	281
Troubleshooting a NIC.....	281
Troubleshooting a Wet System	282
Troubleshooting a Damaged System	283
Troubleshooting the System Battery	284
Troubleshooting Power Supplies	285
Troubleshooting System Cooling Problems	285
Troubleshooting a Fan	286
Troubleshooting System Memory.....	287
Troubleshooting a Hard Drive	289

	Troubleshooting a Storage Controller	290
	Troubleshooting Expansion Cards.....	291
	Troubleshooting Processors	292
	IRQ Assignment Conflicts	293
5	Jumpers and Connectors.....	294
	System Board Connectors.....	294
	Backplane Connectors	295
	3.5" Hard-Drive Direct Backplane	295
	2.5" Hard-Drive Direct Backplane	298
	2.5" Hard-Drive Expander Backplane	300
	Middle Plane Connectors	301
	Interposer Extender for 2U Node Connectors	302
	LSI 2008 SAS Mezzanine Card Connectors.....	303
	1GbE Mezzanine Card Connectors.....	304
	10GbE Mezzanine Card Connectors.....	305
	Power Distribution Board 1 Connectors	306
	Power Distribution Board 2 Connectors	307
	Sensor Board Connectors	307
	Jumper Settings	308
	System Configuration Jumper Settings	308
	Direct Backplane Jumper Settings	309
6	Getting Help.....	310
	Contacting Dell	310
7	Index.....	311

About Your System

Accessing System Features During Startup

The following keystrokes provide access to system features during startup. Note that the hot-keys of SAS/SATA card or PXE support are available in BIOS boot mode only. There is no hot-key to boot through the UEFI.

Keystroke	Description
<F2>	Enters the System Setup program. See “Start Menu” on page 58.
<F11>	Enters the BIOS Boot Manager. See “Boot Manager” to select boot device on page 59.
<F12>	Starts Preboot eXecution Environment (PXE) / iSCSI boot.
<Ctrl><C>	Enters the LSI 2008 SAS Mezzanine Card Configuration Utility. For more information, see the SAS adapter documentation.
<Ctrl><H>	Enters the LSI 9265-8i Card Configuration Utility. For more information, see the documentation for your SAS RAID card.
<Ctrl><Y>	Enters the MegaCLI SAS RAID Management Tool.
<Ctrl><S>	Enters the utility to configure onboard LAN settings for PXE boot. For more information, see the documentation for your integrated LAN.
<Ctrl><I>	Enters onboard SATA Controller’s Configuration Utility.
<Ctrl><D>	Enter the Intel iSCSI setup menu.

Front-Panel Features and Indicators

Figure 1-1. Front Panel –3.5" x12 Hard Drives With Four System Boards

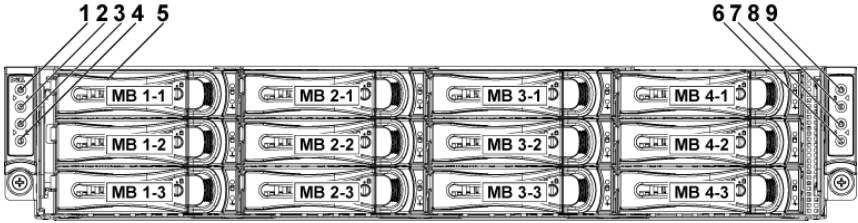

Figure 1-2. Front Panel –3.5" x12 Hard Drives With Two System Boards

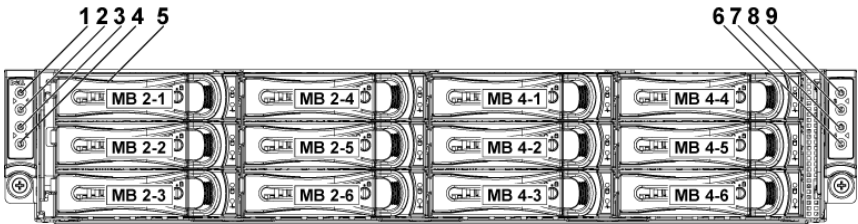
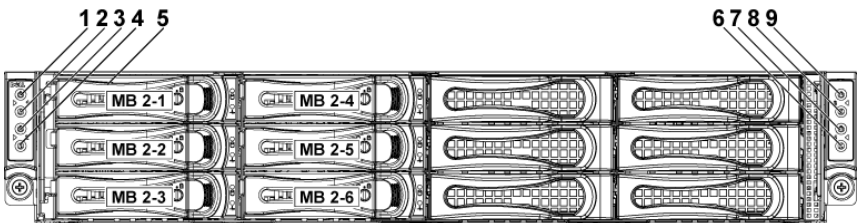

Figure 1-3. Front Panel –3.5" x6 Hard Drives With One System Board



NOTE: Figure 1-3 supports at most 6 hard drives.

Figure 1-4. Front Panel –2.5" x24 Hard Drives With Four System Boards

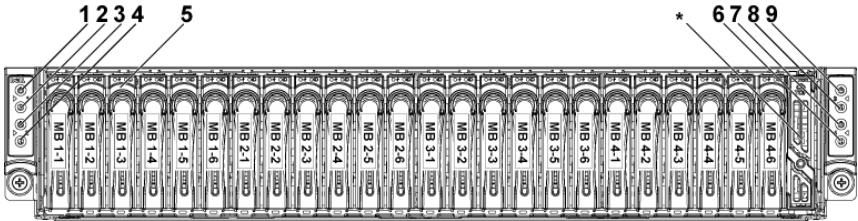

Figure 1-5. Front Panel –2.5" x8 Hard Drives With One System Board

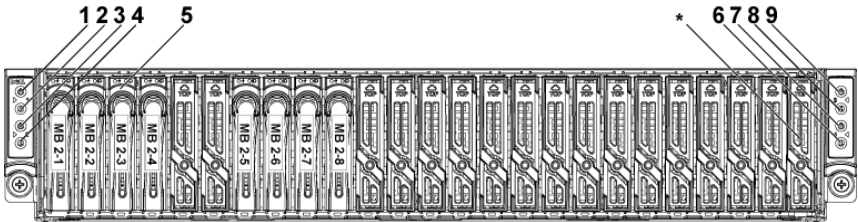
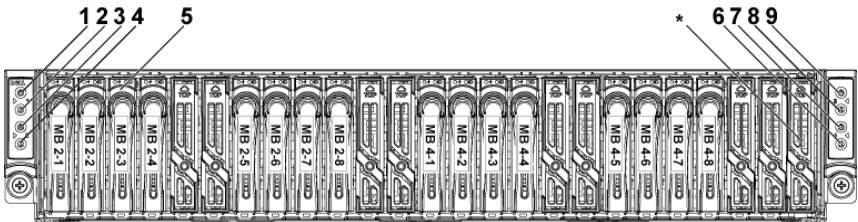

Figure 1-6. Front Panel –2.5" x16 Hard Drives With Two System Boards



NOTE: Figure 1-2, Figure 1-3, Figure 1-5 and Figure 1-6 only support the 2U-node system with the configurations of interposer extender and LSI9265-8i card (or LSI 2008 SAS mezzanine card).

Figure 1-7. Front Panel – 2.5" x24 Hard Drives With One System Board

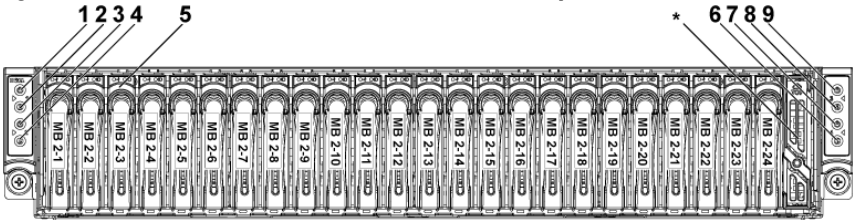

Figure 1-8. Front Panel – 2.5" x24 Hard Drives With Two System Boards

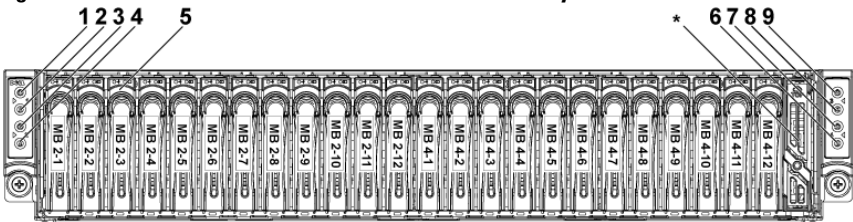

Figure 1-9. Front Panel – 2.5" x24 Hard Drives With Three System Boards

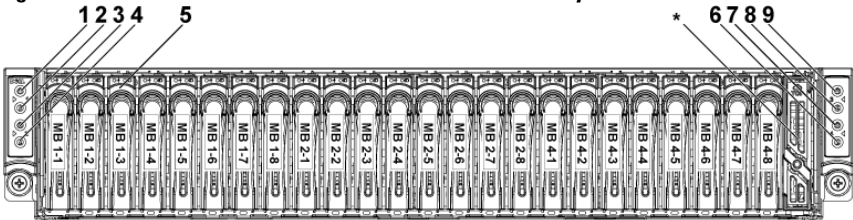
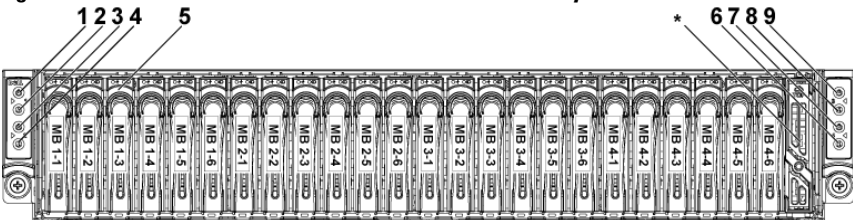



Figure 1-10. Front Panel – 2.5" x24 Hard Drives With Four System Boards





NOTE: Figure 1-7, Figure 1-8, Figure 1-9 and Figure 1-10 support the 2.5-inch Hard Drive Expander Config, For more information on direction details, see the HDD Zoning configuration tool at dell.com/support.

Item	Indicator, Button Or Connector	Icon	Description
1	Power-on indicator/ system state indicator/ power button for system board 1		The power-on indicator turns to green when the system power is on. The power-on indicator turns to amber when the system critical event occurs.
3	Power-on indicator/ system state indicator/ power button for system board 2		The power button controls the DC power supply output to the system. NOTE: When powering on the system, the video monitor can take from several seconds to over 2 minutes to display an image, depending on the amount of DIMM installed in the system.
7	Power-on indicator/ system state indicator/ power button for system board 4		NOTE: On ACPI-compliant operating systems, turning off the system using the power button causes the system to perform a graceful shutdown before power to the system is turned off.
9	Power-on indicator/ system state indicator/ power button for system board 3		NOTE: To force an ungraceful shutdown, press and hold the power button for 5 seconds.

Item	Indicator, Button Or Connector	Icon	Description
2	System identification indicator/button for system board 1		The identification button can be used to locate a particular system and system board within a chassis. When the button is pushed, the blue system status indicator on the front and back blink until the button is pushed again.
4	System identification indicator/button for system board 2		
6	System identification indicator/button for system board 4		
8	System identification indicator/button for system board 3		
5	Hard Drives		Up to twelve hot-swappable 3.5-inch hard drives. Up to twenty four hot-swappable 2.5-inch hard drives.
*	Drive Cover		Applicable only for 2.5-inch hard drive system. This is not a usable drive slot.

Hard-Drive Indicator Patterns

Figure 1-11. 3.5-inch Hard Drive Indicators

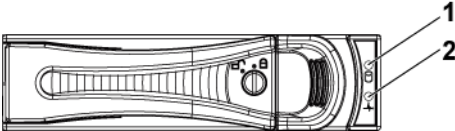

1 hard-drive activity indicator (green)

2 hard-drive status indicator (green and amber)

Figure 1-12. 2.5-inch Hard Drive Indicators



1 hard-drive status indicator (green and amber)

2 hard-drive activity indicator (green)

Table 1-1. Hard-Drive Status Indicators – For 3.5"/2.5" Direct Hard-Drive Backplane

Controller	Hard Drive Type	Function	Activity LED	Status LED	
			Green	Green	Amber
Onboard Controller	SATA2	Drive on-line	Off/ Blinking when active	On	Off
		Fail	Off	On	Off
LSI 9265 /LSI 2008 /LSI 9210	SAS /SATA2	Slot Empty	Off	Off	Off
		Drive On-line/Access	Blinking when active	On	Off
		Drive Fail	Off	Off	On 150 ms Off 150 ms
		Drive Rebuild	Blinking when active	On 400 ms Off 100 ms	Off
		Drive Identify	Blinking when active	On 250 ms Off 250 ms	Off

Table 1-2. Hard-Drive Status Indicators – For 2.5” Hard-Drive Backplane for Expander Configuration

Controller	Hard Drive Type	Function	Activity LED	Status LED		
			Green	Green	Amber	
LSI 9265 /LSI 2008 /LSI 9210	SAS /SATA2	Slot Empty	Off	Off	Off	
		Drive On-line	Blinking when active	On	Off	
		Drive Identify / Preparing for Removal	Blinking when active	On 250 ms Off 250 ms	Off	
		Drive Rebuild	Blinking when active	On 400 ms Off 100 ms	Off	
		Drive Failed	Off	Off	On 150 ms Off 150 ms	
		Predicted Failure (SMART)	Blinking when active	On 500 ms Off 500 ms Off 1000 ms	Off 500 ms On 500 ms Off 1000 ms	
		Rebuild Abort	Off	On 3000 ms Off 9000 ms	Off 6000 ms On 3000 ms Off 000 ms	

Service Tag

The Service Tag locations for 1U node, 2U node and chassis are as follows.

Figure 1-13 Service Tag Location for 1U Node

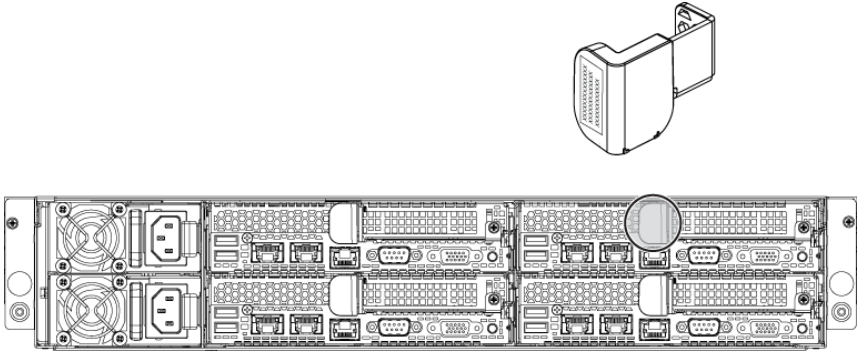

Figure 1-14 Service Tag Location for 2U Node

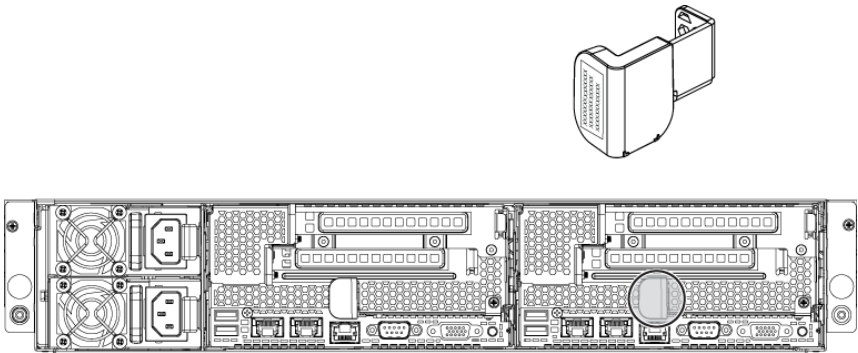

Figure 1-15 Service Tag Location on the Left Front Panel

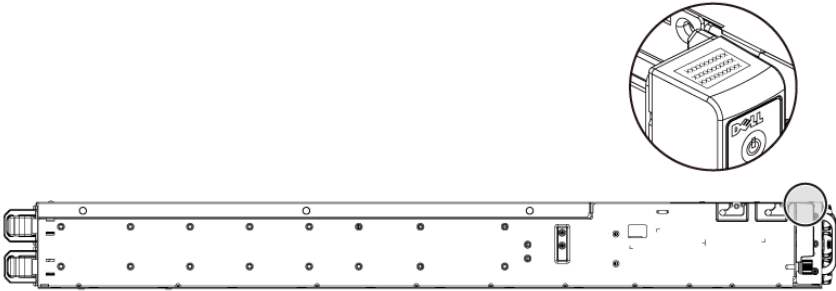
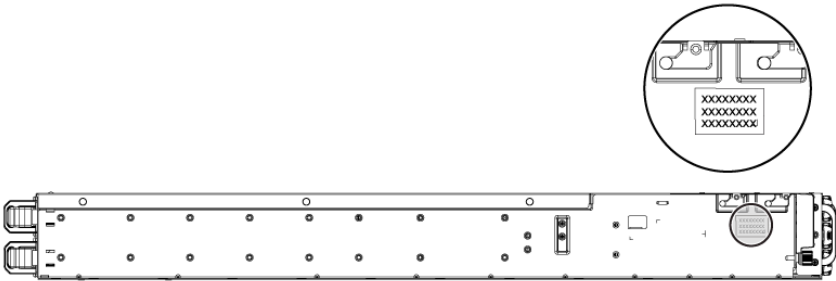
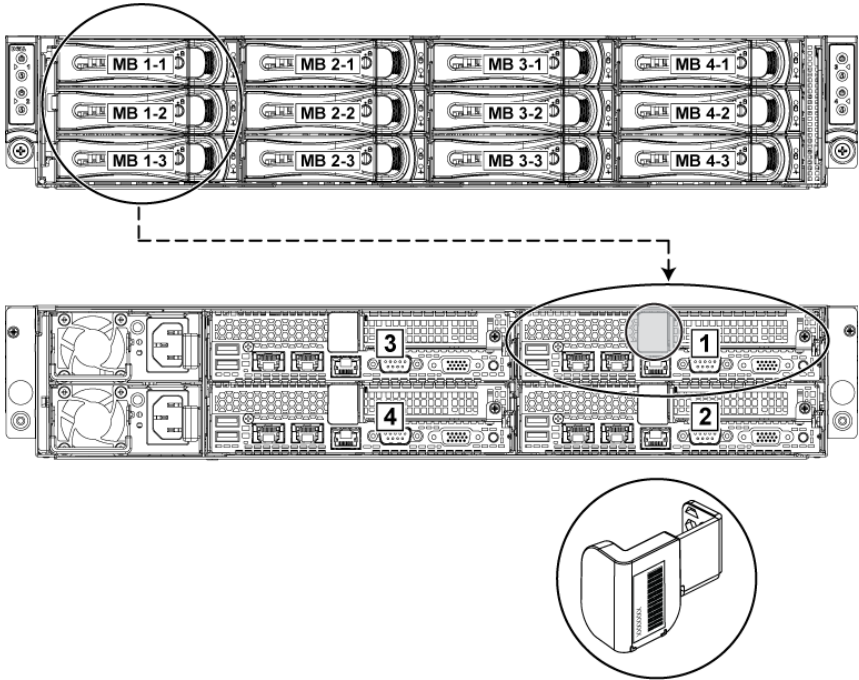

Figure 1-16 Service Tag Location on the Chassis



The linkage of 12 hard drives for four system boards is presented as below. Please refer to Front-Panel Features and Indicators on page 13 for other configurations.

Figure 1-17 Service Tag Linkage



NOTE: HDD's under warranty would be linked to the appropriate service tag of the node.

Back Panel Features and Indicators

Figure 1-18 Back Panel with Four System Boards

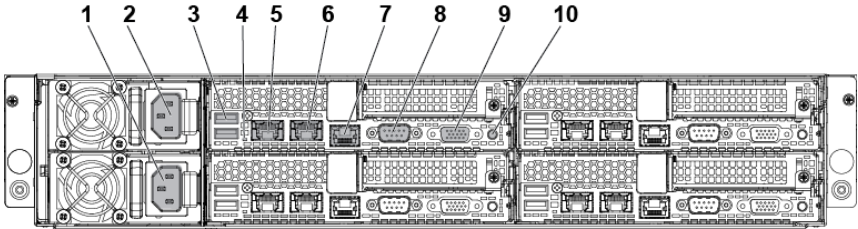
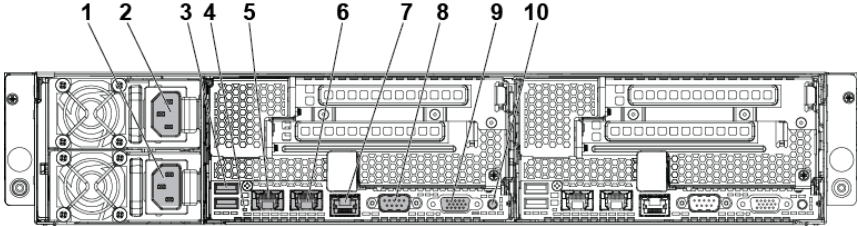









Figure 1-19 Back Panel with Two System Boards



Item	Indicator, Button Or Connector	Icon	Description
1	Power supply 2		1200 W/1400 W
2	Power supply 1		1200 W/1400 W
3	USB ports (2)		Connect USB devices to the system. The ports are USB 2.0-compliant.

Item	Indicator, Button Or Connector	Icon	Description
4	System identification indicator		Both the systems management software and the identification buttons located on the front can cause the indicator to flash blue to identify a particular system and system board. Lights amber when the system needs attention due to a problem.
5	LAN connector 1		Embedded 10/100/1000 NIC connectors.
6	LAN connector 2		Embedded 10/100/1000 NIC connectors.
7	Management port		Dedicated management port.
8	Serial port		Connects a serial device to the system.
9	VGA port		Connects a VGA display to the system.

Item	Indicator, Button Or Connector	Icon	Description
10	Power-on indicator/ system state indicator/ power button		<p>The power-on indicator turns to green when the system power is on.</p> <p>The power-on indicator turns to amber when the system critical event occurs.</p> <p>The power button controls the DC power supply output to the system.</p> <p>NOTE: When powering on the system, the video monitor can take from several seconds to over 2 minutes to display an image, depending on the amount of memory installed in the system.</p> <p>NOTE: On ACPI-compliant operating systems, turning off the system using the power button causes the system to perform a graceful shutdown before power to the system is turned off.</p> <p>NOTE: To force an ungraceful shutdown, press and hold the power button for five seconds.</p>

System-Board Assembly Configurations

Figure 1-20. Enumeration Four System Boards for 1U Node

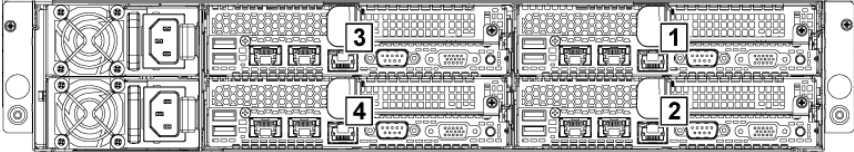

Figure 1-21. Enumeration Three System Boards for 1U Node

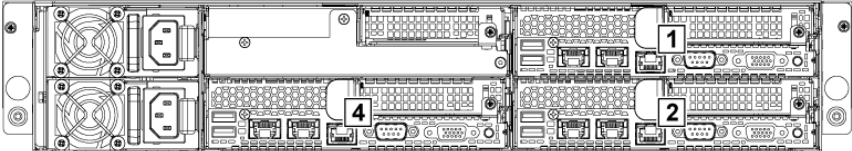

Figure 1-22. Enumeration Two System Boards for 1U Node

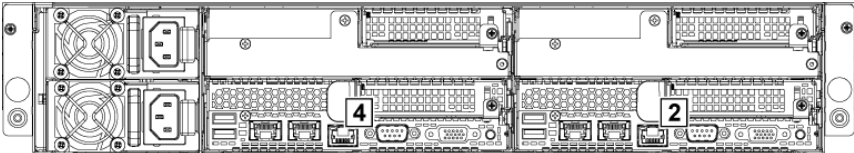

Figure 1-23. Enumeration One System Board for 1U Node

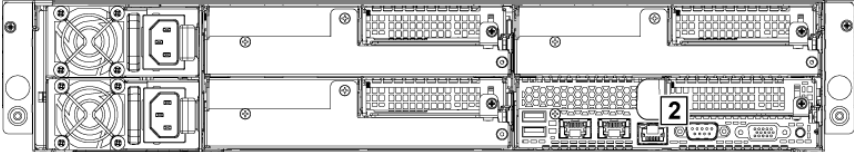

Figure 1-24. Enumeration Two System Boards for 2U Node

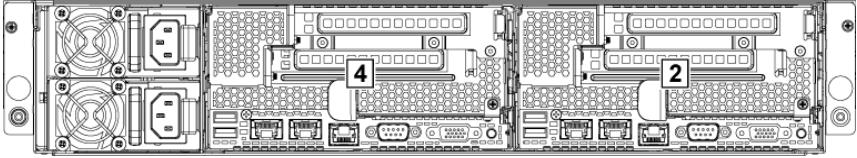
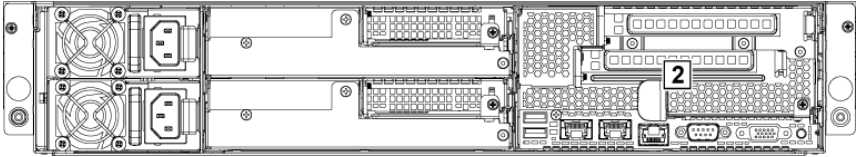
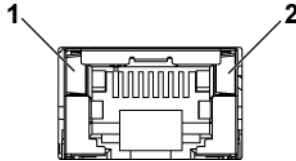

Figure 1-25. Enumeration One System Boards for 2U Node



LAN Indicator Codes

Figure 1-26. LAN Indicators



1 speed indicator

2 link/activity indicator

Component	Indicator	Condition
Speed indicator	Solid amber	Linking at 100Mbps speed
	Solid green	Linking at 1Gbps speed (maximum)
	Blinking green	Linking at 1Gbps speed. Activity is present: <ul style="list-style-type: none"> - Pre OS POST - OS without driver - OS with driver Blinking at speed relative to packet density.
	Off	Linking at 10Mbps speed
Link/activity indicator	Solid green	No access
	Blinking green	LAN accessing / Link up
	Off	Idle

Figure 1-27. LAN Indicators (Management Port)

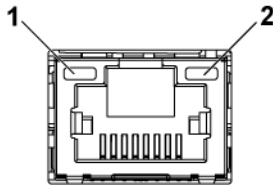

1 speed indicator

2 link/activity indicator

Component	Indicator	Condition
Speed indicator	Blinking green	Linking at 100Mbps speed (maximum)
	Blinking amber	Linking at 10Mbps speed
Link/activity indicator	Solid green	No access
	Blinking green	LAN accessing / Link up
	Off	Idle

Power and System Board Indicator Codes

The LEDs on the system front panel and back panel display status codes during system startup. For location of the LEDs on the front panel, see Figure 1-1 for 3.5” hard drive and Figure 1-4 for 2.5” hard drive systems. For location of the LEDs on the back panel, see Figure 1-18 and Figure 1-19. Table 1-3 lists the status associated with the status codes.

Table 1-3. Status Indicator Codes

Component	Indicator		Condition
Power-on indicator (A bi-color LED on power button)	Green	Solid	Power On (S0)
	Amber	Off	
	Green	Off	BMC critical condition event in Power Off mode (S4/S5)
	Amber	Solid	
	Green	Off	BMC critical condition event in Power On mode (S0)
Amber	Solid		
System identification indicator	Steady Blue		IPMI via Chassis Identify Command On or ID Button Press ID On
	Blinking Blue		Only IPMI via Chassis Identify Command Blink On
	Off		IPMI via Chassis Identify Command Off or ID Button Press ID Off

Power Supply Indicator Codes

1400W

Figure 1-28. Power Supply Status Indicator

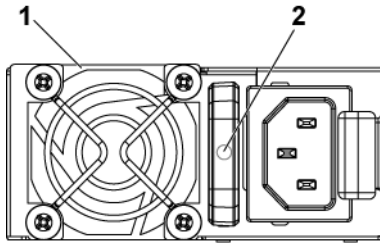

1 power supply

2 AC power indicator

Component	Indicator	Condition
AC power indicator	Solid green	System is on.
	Blinking green	System is off.
	Off	AC off.

1200W

Figure 1-29. Power Supply Status Indicator

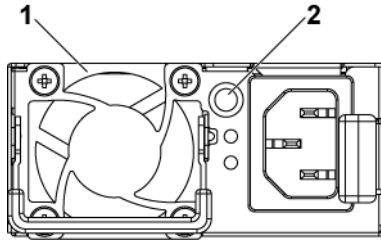

1 power supply

2 AC power Indicator

Component	Indicator	Condition
AC power indicator	Solid green	AC on.
	Yellow	Fault.
	Off	AC off.

BMC Heart Beat LED

The system board provides BMC heart beat LED (LED17) for BMC debugs. The BMC heart beat LED is green. When the system AC power is connected, this LED lights. When BMC firmware is ready, the BMC heart beat LED blinks.

Figure 1-30. BMC Heart Beat LED

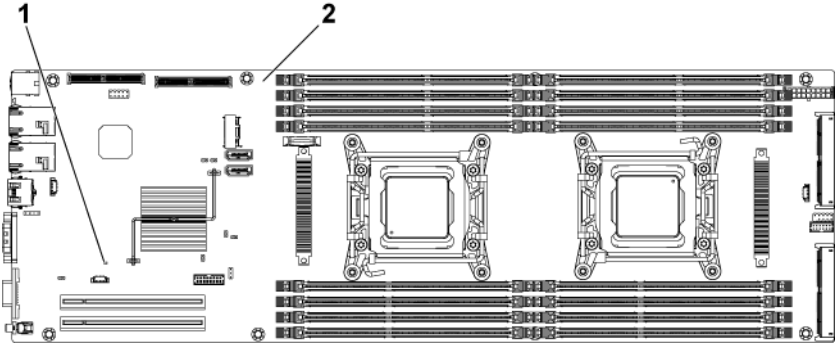

1 BMC heart beat LED

2 system board

Post Error Code

Collecting System Event Log (SEL) for Investigation

Whenever possible, the BIOS will output the current boot progress codes on the video screen. Progress codes are 32-bit quantities plus optional data. The 32-bit numbers include class, subclass, and operation information. The class and subclass fields point to the type of hardware that is being initialized.

The operation field represents the specific initialization activity. Based on the data bit availability to display progress codes, a progress code can be customized to fit the data width. The higher the data bit, the higher the granularity of information that can be sent on the progress port. The progress codes may be reported by the system BIOS or option ROMs.

The Response section in the following table is divided into 3 types:

- 1 **Warning or Not an error** – The message is displayed on the screen. An error record is logged to the SEL. The system will continue booting with a degraded state. The user may want to replace the erroneous unit.
- 2 **Pause** – The message is displayed on the screen, an error is logged to the SEL, and user input is required to continue or not depending on SETUP option. The user can take immediate corrective action or choose to continue booting.
- 3 **Halt** – The message is displayed on the screen, an error is logged to the SEL, and the system cannot boot unless the error is resolved. The user needs to replace the faulty part and restart the system.

Error Code	Error Message	Error Cause	Recovery Method
0010h	Local Console Resource Conflict	Video device initialization failed	Make sure video device is well
0011h	Local Console Controller Error	Video device initialization failed	Make sure video device is well

Error Code	Error Message	Error Cause	Recovery Method
0012h	Local Console Output Error	Video device initialization failed	Make sure video device is well
0013h	ISA IO Controller Error	ISA device's IO initialization failed	Make sure ISA device is well
0014h	ISA IO Resource Conflict	ISA device's IO initialization failed	Make sure ISA device is well
0015h	ISA IO Controller Error	ISA device's IO initialization failed	Make sure ISA device is well
0016h	ISA Floppy Controller Error	Floppy initialization failed	Make sure floppy device is well
0017h	ISA Floppy Input Error	Floppy initialization failed	Make sure floppy device is well
0018h	ISA Floppy Output Error	Floppy initialization failed	Make sure floppy device is well
0019h	USB Read Error	USB initialization failed	Check USB port is well
001Ah	USB Write Error	USB initialization failed	Check USB port is well
001Bh	USB Interface Error	USB port initialization failed	Check USB port is well
001Ch	Mouse Interface Error	Mouse device initialization failed	Make sure mouse device is well
001Eh	Keyboard not Detected	No keyboard be detected	Install keyboard
001Fh	Keyboard Controller Error	KBC initialization failed	Make sure KBC is well
0020h	Keyboard Stuck Key Error	Keyboard Stuck Key Error	Make sure PS2 KB device is well

Error Code	Error Message	Error Cause	Recovery Method
0021h	Keyboard Locked Error	Keyboard Locked Error	Make sure PS2 KB device is well
0023h	Memory Correctable Error	Memory correctable error be detected	Reset power or change new memory
0024h	Memory Uncorrectable Error	Memory uncorrectable error be detected	Reset power or change new memory
0025h	Memory Non-Specific Error	Memory non-specific error	Change new memory
0026h	MP Service Self Test Error	MP service self test error	Change processor
0027h	PCI IO Controller Error	PCI device initialization failed	Make sure PCI device is well
0028h	PCI IO Read Error	PCI device initialization failed	Make sure PCI device is well
0029h	PCI IO Write Error	PCI device initialization failed	Make sure PCI device is well
002Ah	Serial Port not Detected	Serial controller initialization failed	Make sure serial controller is well
002Bh	Serial Port Controller Error	Serial controller initialization failed	Make sure serial controller is well
002Ch	Serial Port Input Error	Serial controller initialization failed	Make sure serial controller is well
002Dh	Serial Port Output Error	Serial controller initialization failed	Make sure serial controller is well
002Eh	Microcode Update Error	Processor microcode load failed	Check microcode

Error Code	Error Message	Error Cause	Recovery Method
002Fh	No Microcode be Updated	Processor microcode load failed	Check processor stepping and microcode are match
8012h	SATA 0 Device not Found!!	SATA 0 device not found	Install SATA device to port 0
8013h	SATA 1 Device not Found!!	SATA 1 device not found	Install SATA device to port 1
8014h	SATA 2 Device not Found!!	SATA 2 device not found	Install SATA device to port 2
8015h	SATA 3 Device not Found!!	SATA 3 device not found	Install SATA device to port 3
8016h	SATA 4 Device not Found!!	SATA 4 device not found	Install SATA device to port 4
8017h	SATA 5 Device not Found!!	SATA 5 device not found	Install SATA device to port 5
8018h	Sparing Mode is not be Configured!!, Please check Memory Configuration!!	Memory sparing mode failed	Change memory configuration for sparing mode
8019h	Mirror Mode is not be Configured!! Please check Memory Configuration!!	Memory mirror mode failed	Change memory configuration for mirror mode
8020h	Supervisor and User passwords have been cleared	SCU password be cleared	Check password jumper status
8021h	CMOS Battery Fault!!	No CMOS battery	Install CMOS battery
8100h	Memory Device disable by BIOS.	Memory Device Error.	Change memory device

System Event Log

Processor Error

Message: "Processor Sensor, IERR error, Processor 1"

Byte	Field	Value	Description
1	NetFunLun	10h	
2	Platform Event Command	02h	
3	Generator ID	01h	Generated by BIOS
4	Event Message Format Version	04h	Event Message Format Revision. 04h for this specification
5	Sensor Type	07h	Processor
6	Sensor Number	04h	Processor Sensor Number (depends on platform)
7	Event Direction Event Type	6Fh	Bit 7: 0 = Assert Event Bit 6: 0 = Event Type Code
8	Event Data1	AXh	00h: IERR 01h: Thermal Trip 02h: FRB1/BIST Failure 03h: FRB2/Hang in POST Failure 04h: FBR3/Processor Startup/Initialization Failure 0Ah: Processor Automatically Throttled
9	Event Data2	XXh	00h: Processor1 01h: Processor2 02h: Processor3 04h: Processor4
10	Event Data3	FFh	FFh: Not Present

Memory ECC

Message: “Memory Sensor, Correctable ECC error, SBE warning threshold, CPU1 DIMM_A1”

Byte	Field	Value	Description
1	NetFunLun	10h	
2	Platform Event Command	02h	
3	Generator ID	01h	Generated by BIOS
4	Event Message Format Version	04h	Event Message Format Revision. 04h for this specification (IPMI 2.0)
5	Sensor Type	0Ch	Memory
6	Sensor Number	60h	Memory Sensor Number (depend on platform)
7	Event Direction Event Type	6Fh	Bit 7: 0 = Assert Event Bit 6: 0 = Event Type Code
8	Event Data1	AXh	00h: Correctable ECC Error 01h: Uncorrectable ECC Error 03h: Memory Scrub Failed 04h: Memory Device Disabled 08h: Spare
9	Event Data2	XXh	Bit 7:4 0x00: SBE warning threshold 0x01: SBE critical threshold 0x0F: Unspecified Bit 3:0 0x00: CPU1 DIMM A1-8 slots (1~8) 0x01: CPU2 DIMM B1-8 slots (9~16) 0x02: CPU3 DIMM C1-8 slots (17~24) 0x03: CPU4 DIMM D1-8 slots (25~32) And so on...

10	Event Data3	XXh	DIMM bit-map location of bits Bit 0=1: DIMM1 error event Bit 1=1: DIMM2 error event ... Bit7=1: DIMM8 error event
----	-------------	-----	---

PCI-E Error

Message: “Critical Interrupt Sensor, PCI PERR, Device#, Function#, Bus#
“

Byte	Field	Value	Description
1	NetFunLun	10h	
2	Platform Event Command	02h	
3	Generator ID	01h	Generated by BIOS
4	Event Message Format Version	04h	Event Message Format Revision. 04h for this specification.
5	Sensor Type	13h	Critical Interrupt
6	Sensor Number	73h	PCI Sensor ID (depend on platform)
7	Event Direction Event Type	6Fh	Bit 7: 0 = Assert Event Bit 6: 0 = Event Type Code
8	Event Data1	AXh	04h: PCI PERR 05h: PCI SERR 07h: Bus Correctable Error 08h: Bus Uncorrectable Error 0Ah: Bus Fatal Error
9	Event Data2	XXh	Bit 7:3 Device Number Bit 2:0 Function Number
10	Event Data3	XXh	Bit 7:0 Bus Number

IOH Core Error

Message: “Critical Interrupt Sensor, Fatal Error, xxxx bit, QPI[0] Error”

Byte	Field	Value	Description
1	NetFunLun	10h	
2	Platform Event Command	02h	
3	Generator ID	01h	Generated by BIOS
4	Event Message Format Version	04h	Event Message Format Revision. 04h for this specification.
5	Sensor Type	C0h	OEM Defined Interrupt
6	Sensor Number	XXh	71h: QPI Sensor ID (depend on platform) 72h: INT Sensor ID (depend on platform)
7	Event Direction Event Type	6Fh	Bit 7: 0 = Assert Event Bit 6: 0 = Event Type Code
8	Event Data1	AXh	07h: Core 08h: Non-Fatal 0Ah: Fatal
9	Event Data2	XXh	Local Error Bit
10	Event Data3	XXh	00h: QPI[0] Error 01h: QPI[1] Error 02h: QPI[2] Error 03h: QPI[3] Error 04h: QPI[0] Protocol Error 05h: QPI[1] Protocol Error 06h: QPI[2] Protocol Error 07h: QPI[3] Protocol Error 23h: Miscellaneous Error 24h: IOH Core Error

SB Error

Message: “Critical Interrupt Sensor, Correctable, MCU Parity Error”

Byte	Field	Value	Description
1	NetFunLun	10h	
2	Platform Event Command	02h	
3	Generator ID	01h	Generated by BIOS
4	Event Message Format Version	04h	Event Message Format Revision. 04h for this specification.
5	Sensor Type	13h	Critical Interrupt
6	Sensor Number	77h	SB Sensor ID (depend on platform)
7	Event Direction Event Type	6Fh	Bit 7: 0 = Assert Event Bit 6: 0 = Event Type Code
8	Event Data1	AXh	07h: Correctable 08h: Uncorrectable
9	Event Data2	XXh	Bit 7:5Reserved Local error bit number (4 ~ 0) 00000b: HT Periodic CRC Error 00001b: HT Protocol Error 00010b: HT Flow-Control Buffer Overflow 00011b: HT Response Error 00100b: HT Per-Packet CRC Error 00101b: HT Retry Counter Error 00111b: MCU Parity Error
10	Event Data3	FFh	FFh: Not Present

POST Start Event

Message: "System Event, POST starts with BIOS xx.xx.xx"

Byte	Field	Value	Description
1	NetFunLun	10h	
2	Platform Event Command	02h	
3	Generator ID	01h	Generated by BIOS
4	Event Message Format Version	04h	Event Message Format Revision. 04h for this specification.
5	Sensor Type	12h	System Event
6	Sensor Number	81h	POST Start (depend on platform)
7	Event Direction Event Type	6Fh	Bit 7: 0 = Assert Event Bit 6: 0 = Event Type Code
8	Event Data1	AXh	01h: OEM System Boot Event
9	Event Data2	XXh	7~4: BIOS 1st Field Version (0~15) 3~0: BIOS 2nd Field Version higher 4bits (0~63)
10	Event Data3	XXh	7~6: BIOS 2nd Field Version lower 2bits (0~63) 5~0: BIOS 3rd Field Version (0~63)

POST End Event

Byte	Field	Value	Description
1	NetFunLun	10h	
2	Platform Event Command	02h	
3	Generator ID	01h	Generated by BIOS
4	Event Message Format Version	04h	Event Message Format Revision. 04h for this specification.

5	Sensor Type	12h	System Event
6	Sensor Number	85h	POST End (depend on platform)
7	Event Direction Event Type	6Fh	Bit 7: 0 = Assert Event Bit 6: 0 = Event Type Code
8	Event Data1	AXh	01h: OEM System Boot Event
9	Event Data2	XXh	Bit 7 = Boot Type 0b: PC Compatible Boot (Legacy) 1b: uEFI Boot Bit 3:0 = Boot Device 0001b: Force PXE Boot 0010b: NIC PXE Boot 0011b: Hard Disk Boot 0100b: RAID HDD Boot 0101b: USB Storage Boot 0111b: CD/DVD ROM Boot 1000b: iSCSI Boot 1001b: uEFI Shell 1010b: ePSA Diagnostic Boot
10	Event Data3	FFh	FFh: Not Present

POST Error Code Event

Message: "System Firmware Progress, POST error code: UBLBh."

Byte	Field	Value	Description
1	NetFunLun	10h	
2	Platform Event Command	02h	
3	Generator ID	01h	Generated by BIOS
4	Event Message Format Version	04h	Event Message Format Revision. 04h for this specification.

5	Sensor Type	0Fh	System Firmware Progress
6	Sensor Number	86h	POST Error (depend on platform)
7	Event Direction Event Type	6Fh	Bit 7: 0 = Assert Event Bit 6: 0 = Event Type Code
8	Event Data1	AXh	00: System Firmware Error (POST Error)
9	Event Data2	XXh	Upper Byte
10	Event Data3	XXh	Lower Byte

BIOS Recovery Event

Byte	Field	Value	Description
1	NetFunLun	10h	
2	Platform Event Command	02h	
3	Generator ID	01h	Generated by BIOS
4	Event Message Format Version	04h	Event Message Format Revision. 04h for this specification.
5	Sensor Type	12h	System Event
6	Sensor Number	89h	BIOS Recovery fail (depend on platform)
7	Event Direction Event Type	6Fh	Bit 7: 0 = Assert Event Bit 6: 0 = Event Type Code
8	Event Data1	AXh	01h: OEM BIOS recovery Event
9	Event Data2	XXh	01h:Start Recovery 02h:Recovery Success 03h:Load Image Fail 04h:Signed Fail
10	Event Data3	FFh	FFh: Not Present

ME Fail Event

Byte	Field	Value	Description
1	NetFunLun	10h	
2	Platform Event Command	02h	
3	Generator ID	01h	Generated by BIOS
4	Event Message Format Version	04h	Event Message Format Revision. 04h for this specification.
5	Sensor Type	12h	System Event
6	Sensor Number	8Ah	ME fail (depend on platform)
7	Event Direction Event Type	6Fh	Bit 7: 0 = Assert Event Bit 6: 0 = Event Type Code
8	Event Data1	AXh	01h: OEM ME fail Event
9	Event Data2	XXh	01h:ME fail
10	Event Data3	FFh	FFh: Not Present

SEL Generator ID

Generator ID	
BIOS	0x0001
BMC	0x0020
ME	0x002C
Windows 2008	0x0137

Sensor Data Record



NOTE: The abbreviations used in the following table are:

SI: Sensor Initialization

DM: Deassertion Mask

SC: Sensor Capabilities

RM: Reading Mask

AM: Assertion Mask

TM: Settable/Readable Threshold Mask

Event Log Only: the sensor will be only used to explain event log, and will show disable about sensor state.

Record ID	Sensor Number	Sensor Name	Sensor Type	Event/Reading Type	Offset
0004h	0x01	SEL Fullness	Event Logging Disabled (10h)	Sensor-specific (6Fh)	SI: 67h SC: 40h AM: 0035h DM: 0000h RM: 0035h
0001h	0x02	P1 ThermalTrip	Processor (07h)	Sensor-specific (6Fh)	SI: 01h SC: 40h AM: 0002h DM: 0000h RM: 0002h
0002h	0x03	P2 ThermalTrip	Processor (07h)	Sensor-specific (6Fh)	SI: 01h SC: 40h AM: 0002h DM: 0000h RM: 0002h
0003h	0x04	CPU ERR2	Processor (07h)	Sensor-specific (6Fh)	SI: 01h SC: 40h AM: 0001h DM: 0000h RM: 0001h
0005h	0x05	12V Standby Voltage	(02h)	Threshold (01h)	SI: 7Fh SC: 59h AM: 7A95h DM: 7A95h TM: 3F3Fh

Record ID	Sensor Number	Sensor Name	Sensor Type	Event/Reading Type	Offset
0007h	0x06	5V	Voltage (02h)	Threshold (01h)	SI: 7Fh SC: 59h AM: 7A95h DM: 7A95h TM: 3F3Fh
0006h	0x07	5V Standby	Voltage (02h)	Threshold (01h)	SI: 7Fh SC: 59h AM: 7A95h DM: 7A95h TM: 3F3Fh
0009h	0x08	3.3V	Voltage (02h)	Threshold (01h)	SI: 7Fh SC: 59h AM: 7A95h DM: 7A95h TM: 3F3Fh
0008h	0x09	3.3V Standby	Voltage (02h)	Threshold (01h)	SI: 7Fh SC: 59h AM: 7A95h DM: 7A95h TM: 3F3Fh
001Ah	0x0A	Battery low	Battery (29h)	Sensor-specific (6Fh)	SI: 67h SC: 40h AM: 0001h DM: 0000h TM: 0001h
000Bh	0x40	MEZZ1 TEMP	Temperature (01h)	Threshold (01h)	SI: 7Fh SC: 68h AM: 0A95h DM: 7A95h TM: 3838h
000Ch	0x41	CPU1 Temp	Temperature (01h)	Threshold (01h)	SI: 7Fh SC: 68h AM: 0A95h DM: 7A95h TM: 3838h

Record ID	Sensor Number	Sensor Name	Sensor Type	Event/Reading Type	Offset
000Dh	0x42	CPU2 Temp	Temperature (01h)	Threshold (01h)	SI: 7Fh SC: 68h AM: 0A95h DM: 7A95h TM: 3838h
000Eh	0x43	DIMM ZONE 1 Temp	Temperature (01h)	Threshold (01h)	SI: 7Fh SC: 68h AM: 0A95h DM: 7A95h TM: 3838h
000Fh	0x44	DIMM ZONE 2 Temp	Temperature (01h)	Threshold (01h)	SI: 7Fh SC: 68h AM: 0A95h DM: 7A95h TM: 3838h
0012h	0x45	PCH Temp	Temperature (01h)	Threshold (01h)	SI: 7Fh SC: 68h AM: 0A95h DM: 7A95h TM: 3838h
0017h	0x60	Memory	Memory (0Ch)	Sensor-specific (6Fh)	SI: 01h SC: 40h AM: 0023h DM: 0000h RM: 0023h
0013h	0xA0	Watchdog	Watchdog 2 (23h)	Sensor-specific (6Fh)	SI: 67h SC: 40h AM: 000Fh DM: 0000h RM: 000Fh
0016h	0xA2	AC lost (Event Log Only)	Power Unit (09h)	Sensor-specific (6Fh)	SI: 01h SC: 40h AM: 0010h DM: 0000h RM: 0010h

Record ID	Sensor Number	Sensor Name	Sensor Type	Event/Reading Type	Offset
N/A	0x2F	Session Audit (Event Log Only)	Session Audit (2Ah)	N/A	N/A
0019h	0xA3	Sys Pwr Monitor	System ACPI Power State (22h)	Sensor-specific (6Fh)	SI: 01h SC: 40h AM: 0021h DM: 0000h RM: 0021h
Dynamic	0xB6	PSU1 Status	Power Supply (08h)	Sensor-specific (74h)	SI: 67h SC: 40h AM: 000Bh DM: 000Bh RM: 000Bh
Dynamic	0xB7	PSU2 Status	Power Supply (08h)	Sensor-specific (74h)	SI: 67h SC: 40h AM: 000Bh DM: 000Bh RM: 000Bh
Dynamic	0xB8	PSU3 Status	Power Supply (08h)	Sensor-specific (74h)	SI: 67h SC: 40h AM: 000Bh DM: 000Bh RM: 000Bh
Dynamic	0xB9	PSU4 Status	Power Supply (08h)	Sensor-specific (74h)	SI: 67h SC: 40h AM: 000Bh DM: 000Bh RM: 000Bh
Dynamic	0xE1	PSU Mismatch	Power Supply (08h)	Sensor-specific (0x6F)	SI: 67h SC: 40h AM: 0040h DM: 0040h RM: 0040h

Record ID	Sensor Number	Sensor Name	Sensor Type	Event/Reading Type	Offset
Dynamic	0xE2	PSU Redundancy	Power Supply (08h)	Discrete(0x0Bh)	SI: 67h SC: 00h AM: 002Fh DM: 000Bh RM: 002Fh
Dynamic	0x64	12V	Voltage(02h)	Threshold(01h)	Variable
Dynamic	0xB1	Inlet Temp	Temperature (01h)	Threshold(01h)	Variable
Dynamic	0xB3	Input Voltage	Voltage(02h)	Threshold(01h)	Variable
Dynamic	0xB4	Input Current	Current(03h)	Threshold(01h)	Variable
Dynamic	0xB5	SC FW Status	Management Subsystem Health(28h)	Sensor-specific (0x6F)	Variable
Dynamic	0xC7	HDD 1 Status	Drive Slot (Bay) (0Dh)	Sensor-specific (0x6F)	Variable
Dynamic	0xC8	HDD 2 Status	Drive Slot (Bay) (0Dh)	Sensor-specific (0x6F)	Variable
Dynamic	0xC9	HDD 3 Status	Drive Slot (Bay) (0Dh)	Sensor-specific (0x6F)	Variable
Dynamic	0xCA	HDD 4 Status	Drive Slot (Bay) (0Dh)	Sensor-specific (0x6F)	Variable
Dynamic	0xCB	HDD 5 Status	Drive Slot (Bay) (0Dh)	Sensor-specific (0x6F)	Variable
Dynamic	0xCC	HDD 6 Status	Drive Slot (Bay) (0Dh)	Sensor-specific (0x6F)	Variable
Dynamic	0xD3	FAN_1	Fan(04h)	Threshold (01h)	Variable
Dynamic	0xD4	FAN_2	Fan(04h)	Threshold (01h)	Variable
Dynamic	0xD5	FAN_3	Fan(04h)	Threshold (01h)	Variable
Dynamic	0xD6	FAN_5	Fan(04h)	Threshold (01h)	Variable
Dynamic	0xD7	FAN_6	Fan(04h)	Threshold (01h)	Variable

Other Information You May Need



WARNING: See the safety and regulatory information that shipped with your system. Warranty information may be included within this document or as a separate document.

The *Getting Started Guide* provides an overview of rack installation, system features, setting up your system, and technical specifications.



NOTE: Always check for updates on support.dell.com/manuals and read the updates first because they often supersede information in other documents.

Fresh Air Support

Expanded Operating Temperature	
10% of annual operating hours	<p>5 °C to 40 °C, 5% to 85% RH with 26 °C max. dew point.</p> <p>For temperatures between 35 °C and 40 °C, de-rate maximum allowable dry bulb temperature by 1 °C/175 meters above 950 meters (1 °F per 319 feet).</p>
1% of annual operating hours	<p>-5 °C to 45 °C, 5% to 90% RH with 26 °C dew point.</p> <p>For temperatures between 40 °C and 45 °C, de-rate maximum allowable dry bulb temperature by 1 °C/125 meters above 950 meters (1 °F per 228 feet).</p> <p>NOTE: When operating in the expanded temperature range, ambient temperature warnings may be reported in the System Event Log.</p> <p>NOTE: No cold start up below 5 °C.</p> <p>NOTE: The operating temperature specification is for a maximum altitude of 3050 meters (10,000 feet).</p> <p>NOTE: 1U and 2U nodes support the 130W (8 core), 130W (4 core) and 135W processors with the specific configurations of HDD, PCI-E and Mezzanine card. Please refer to the following statements and matrixes of Fresh Air Support for details.</p> <ul style="list-style-type: none">• The numbers of HDD in the tables below list the total quantity supported per chassis.• No GPU support.

	<ul style="list-style-type: none"> • 1U node can't support PCI-E and Mezzanine card at the same time. • 2U node only can be installed one PCI-E and Mezzanine card by each MB.
--	--

Matrix of Fresh Air Support of 1U node with 3.5" HDD configuration				
	10 ~ 30 °C	35 °C	40 °C	45 °C
130W (8 core)	12 * HDD	10 * HDD	4* HDD	4 * HDD w/o PCI-E card, w/o mezzanine card
130W (4 core)	8 * HDD	4 * HDD w/o PCI-E card, w/o mezzanine card	not support	not support
135W	4 * HDD w/o PCI-E card, 1 * mezzanine card	not support	not support	not support

Matrix of Fresh Air Support of 1U node with 2.5" HDD configuration				
	10 ~ 30 °C	35 °C	40 °C	45 °C
130W (8 core)	24 * HDD	24 * HDD	8* HDD	4 * HDD w/o PCI-E card, w/o mezzanine card
130W (4 core)	16 * HDD	4 * HDD w/o PCI-E card, 1 * mezzanine card	not support	not support
135W	8 * HDD w/o PCI-E card, 1 * mezzanine card	not support	not support	not support

Matrix of Fresh Air Support of 2U node with 3.5" HDD configuration				
	10 ~ 30 °C	35 °C	40 °C	45 °C
130W (8 core)	12 * HDD	12 * HDD	8 * HDD	8 * HDD 1 * PCI-E card, w/o mezzanine card
130W (4 core)	12 * HDD	10 * HDD	8 * HDD	8 * HDD 1 * PCI-E card, w/o mezzanine card
135W	12 * HDD	8 * HDD 1 * PCI-E card, 1 * mezzanine card	4 * HDD 1 * PCI-E card, w/o mezzanine card	not support

Matrix of Fresh Air Support of 2U node with 2.5" HDD configuration				
	10 ~ 30 °C	35 °C	40 °C	45 °C
130W (8 core)	24 * HDD	24 * HDD	16 * HDD	16 * HDD 1 * PCI-E card, w/o mezzanine card
130W (4 core)	24 * HDD ,	24 * HDD	16 * HDD	8 * HDD 1 * PCI-E card, w/o mezzanine card
135W	16 * HDD	8 * HDD 1 * PCI-E card, 1 *mezzanine card	4 * HDD 1 * PCI-E card, w/o mezzanine card	not support

Micro SD Card and SD Card Socket Location

Micro SD Card Socket Location	Located on the 1U riser card, see Figure 3-33.
SD Card Socket Location	Located on the 2U riser card, see Figure 3-35.

Using the System Setup Program

Start Menu

The system employs the latest Insyde® BIOS, which is stored in Flash memory. The Flash memory supports the Plug and Play specification, and contains a System Setup program, the Power On Self Test (POST) routine, and the PCI auto-configuration utility.

This system board supports system BIOS shadowing, enabling the BIOS to execute from 64-bit onboard write-protected DRAM.

This Setup utility should be executed under the following conditions:

- When changing the system configuration, configure items such as:
 - Hard drives, diskette drives, and peripherals
 - Password protection from unauthorized use
 - Power management features
- When a configuration error is detected by the system and you are prompted to make changes to the Setup utility
- When redefining the communication ports to prevent any conflicts.
- When changing the password or making other changes to the security setup.



NOTE: Only items in brackets [] can be modified. Items that are not in brackets are display only.

System Setup Options at Boot

<F2>	Initiate Setup during POST
<F8>	Load customized defaults
<F9>	Load optimal defaults in Setup menu.

<F10>

Save Settings and exit in BIOS Setup

Boot Manager

During BIOS POST, press F11 can enter Boot Manager to select boot device.



If UEFI OS was installed, the UEFI OS partition will be present on the boot option.

- Boot Manager - UEFI Mode

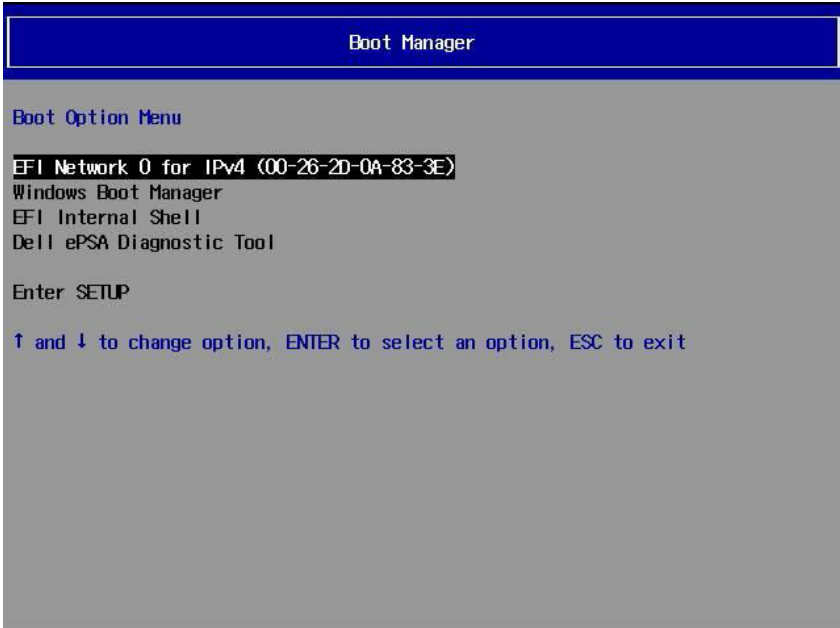

- Boot Manager – Legacy Mode

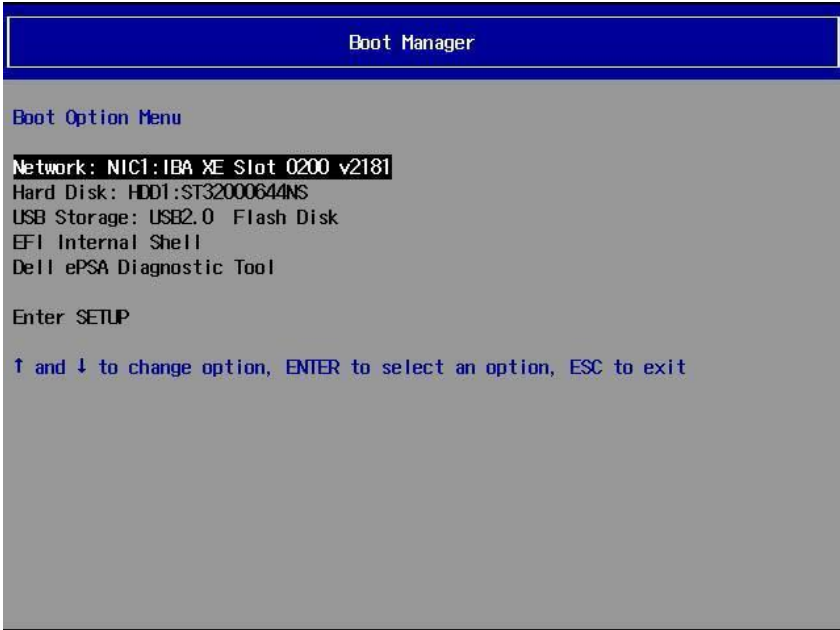

Console Redirection

The console redirection allows a remote user to diagnose and fix problems on a server, which has not successfully booted the OS. The centerpiece of the console redirection is the BIOS Console. The BIOS Console is a Flash ROM-resident utility that redirects input and output over a serial or modem connection.

The BIOS supports console redirection to a serial port. If serial port based headless server support is provided by the system, the system must provide support for redirection of all BIOS driven console I/O to the serial port. The

driver for the serial console must be capable of supporting the functionality documented in the ANSI Terminal Definition.

After reconnecting the console, if the display is abnormal it is recommended that you reflash the screen by pressing the <Ctrl> <R>.

The following are different modes for Console Redirection:

- 1 External serial port.
- 2 Internal serial connector as Serial Over LAN (SOL).
- 3 BMC SOL.

Enabling and Configuring Console Redirection

External Serial Port

To enable SOL feature in the mode of external serial port, please perform the following steps:

- 1 Connect the serial cable to the serial port and host system. For location of the serial port on the back panel, see Figure 1-18 item 8.
- 2 Enter the server BIOS setup screen.
- 3 Enter Set BMC LAN Configuration screen and verify the following settings:
 - Remote Access: enabled
 - Serial port number: COM1
 - Serial Port Mode: 115200 8,n,1
 - Flow Control: None
 - Redirection After BIOS POST: Always
 - Terminal Type: VT100

To do this, see “Remote Access Configuration” on page 94. Note that the last four options need to sync with the host and client.

Internal Serial Connector as SOL

- 1 Connect the serial cable with internal serial connector and host system. For the location of internal serial connector on the system board, please see Figure 5-1 item 15.
- 2 Enter the server BIOS setup screen.

3 Enter Set BMC LAN Configuration screen and verify the following settings:

- Remote Access: enabled
- Serial port number: COM2 as SOL
- Serial Port Mode: 115200 8,n,1
- Flow Control: None
- Redirection After BIOS POST: Always
- Terminal Type: VT100

To do this, see “Remote Access Configuration” on page 94. Note that the host and client need to have the same network section.

BMC Serial Over LAN

There are two modes of BMC LAN port configuration-Dedicated NIC and Shared NIC to enable Serial Over LAN (SOL) feature. The following steps show setup process about the LAN connection and BIOS setup settings for Dedicated-NIC and Shared-NIC.

To enable SOL feature in the mode of Dedicated-NIC, please perform the following steps:

- 1 Connect the LAN cable to management port. For location of management port on the back panel, see Figure 1-18 item 7.
- 2 Enter the server BIOS setup screen.
- 3 Enter Set BMC LAN Configuration screen and verify the following settings:
 - Remote Access: enabled
 - Serial port number: COM2 as SOL
 - Serial Port Mode: 115200 8, n, 1
 - Flow Control: None
 - Redirection After BIOS POST: Always
 - Terminal Type: VT100

To do this, see “Remote Access Configuration” on page 94. Note that the last four options need to sync with the host and client.

- 4 Enter LAN Configuration screen and verify the following settings:

- BMC LAN Port Configuration: Dedicated-NIC
- DHCP Enabled: Disabled or Enabled (Enabled if DHCP server support)
- IP Address: 192.168.001.003
- Subnet Mask: 255.255.255.000
- Gateway Address: 000.000.000.000

To do this, see “Set BMC LAN Configuration” on page 93. Note that the host and client need to have the same network section.

To enable SOL feature in the mode of Shared-NIC, please perform the following steps:

- 1 Connect the LAN cable to NIC connector 1. For location of NIC connector 1 on the back panel, see Figure 1-18 item 5.
- 2 Enter the server BIOS setup screen.
- 3 Enter Set BMC LAN Configuration screen and verify the following settings:
 - Remote Access: enabled
 - Serial port number: COM2
 - Serial Port Mode: 115200 8, n, 1
 - Flow Control: None
 - Redirection After BIOS POST: Always
 - Terminal Type: ANSI

To do this, see “Remote Access Configuration” on page 94. Note that the last four options need to sync with the host and client.

- 4 Enter LAN Configuration screen and verify the following settings:
 - BMC LAN Port Configuration: Shared-NIC
 - DHCP Enabled: Disabled or Enabled (Enabled if DHCP server support)
 - IP Address: 192.168.001.003
 - Subnet Mask: 255.255.255.000
 - Gateway Address: 000.000.000.000

To do this, see “Set BMC LAN Configuration” on page 93. Note that the host and client need to have the same network section.

Serial Port Connection List

Signal Type	Setup Option			OS Setting	Output
	Remote Access	Serial Port Number	Serial Port Address		
Serial Console Redirection	Enabled	COM1	3F8h/2F8h	ttyS0	Serial Port
	Enabled	COM1	2F8h/3F8h	ttyS1	
BMC Serial Over LAN	Enabled	COM2 as SOL	3F8h/2F8h	ttyS1	Management Port
	Enabled	COM2 as SOL	2F8h/3F8h	ttyS0	
Scorpion Serial Over LAN	Enabled	COM2 as SOL	3F8h/2F8h	ttyS1	Internal Serial Connector
	Enabled	COM2 as SOL	2F8h/3F8h	ttyS0	

Main Menu

The main menu displays information about your system boards and BIOS.

Main Screen

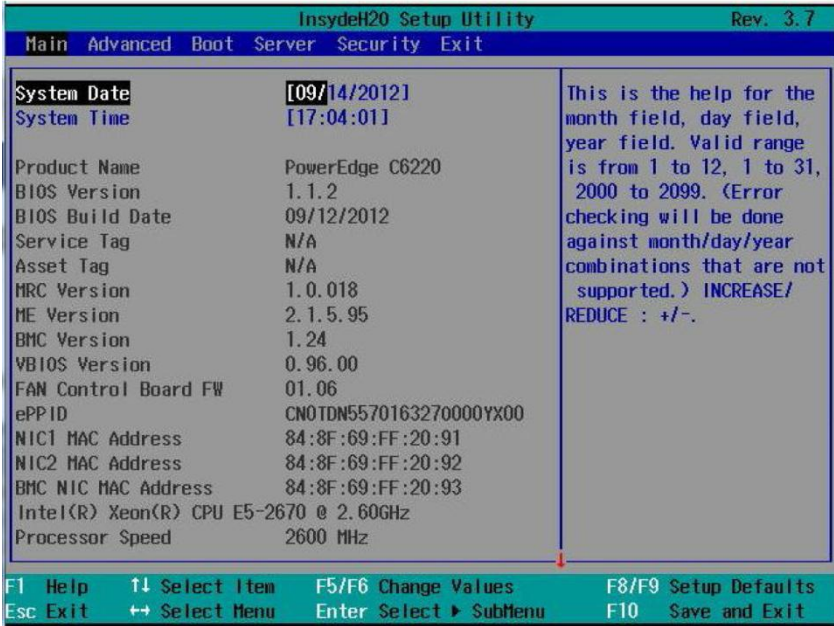

NOTE: The options for the System Setup program change based on the system configuration.



NOTE: The System Setup program defaults are listed under their respective options in the following sections, where applicable.

Option	Description
System Date	Displays the current date.
System Time	Displays the current time.
Product Name	Displays the product name.

BIOS Version	Displays the BIOS version.
BIOS Build Date	Displays the Build date.
Service Tag	Displays the service tag of the product. The service tag field should match what is physically on the service tag of the node.
Asset Tag	Displays the asset tag of the product.
MRC Version	Displays the version of MRC.
ME Version	Displays the current ME version.
BMC Version	Displays the version of BMC. Note: BMC version will not present if not detected.
VBIOS Version	Displays the current Video BIOS version.
Fan Control Board FW	Displays the current fan control board firmware version. Note: Fan Control Board FW version will not present if not detected.
ePPID	Displays the eppid of the product.
NIC1 MAC Address	Displays the MAC address of NIC1.
NIC2 MAC Address	Displays the MAC address of NIC2.
BMC NIC MAC Address	Displays the MAC address of BMC NIC.
Processor Type	Displays the processor type.
Processor Speed	Displays the processor speed.
Processor Core	Displays the processor core.
System Memory Size	Displays total memory size.
System Memory Speed	Displays the current speed of the memory.
System Memory Voltage	Displays total memory voltage.

Advanced Menu

This option displays a table of items that defines advanced information about your system.



CAUTION: Making incorrect settings to items on these pages may cause the system to malfunction. Unless you have experience adjusting these items, we recommend that you leave these settings at the default values. If making settings to items on these pages causes your system to malfunction or prevents the system from booting, open BIOS and choose Load Optimal Defaults in the Exit menu to boot up normally.

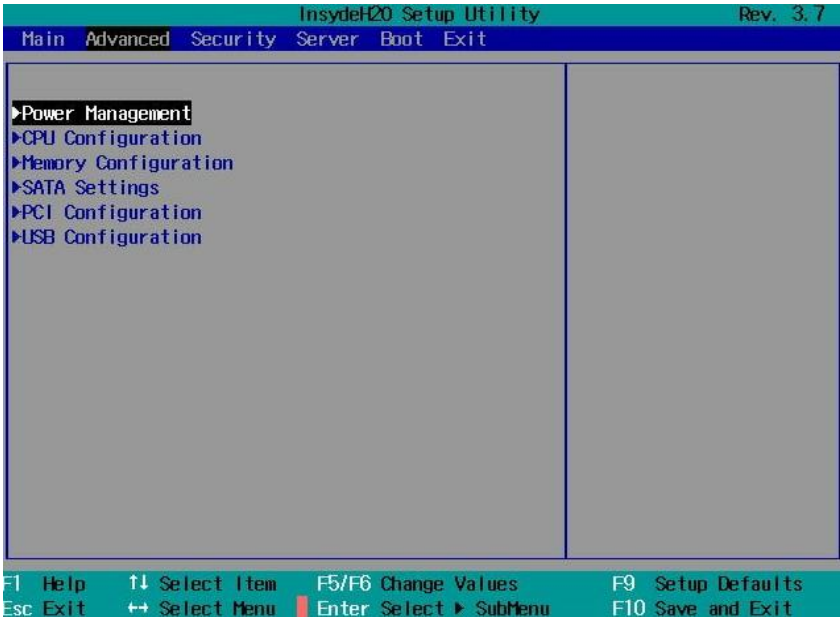

Power Management

Scroll to this item and press **Enter** to view the following screen:

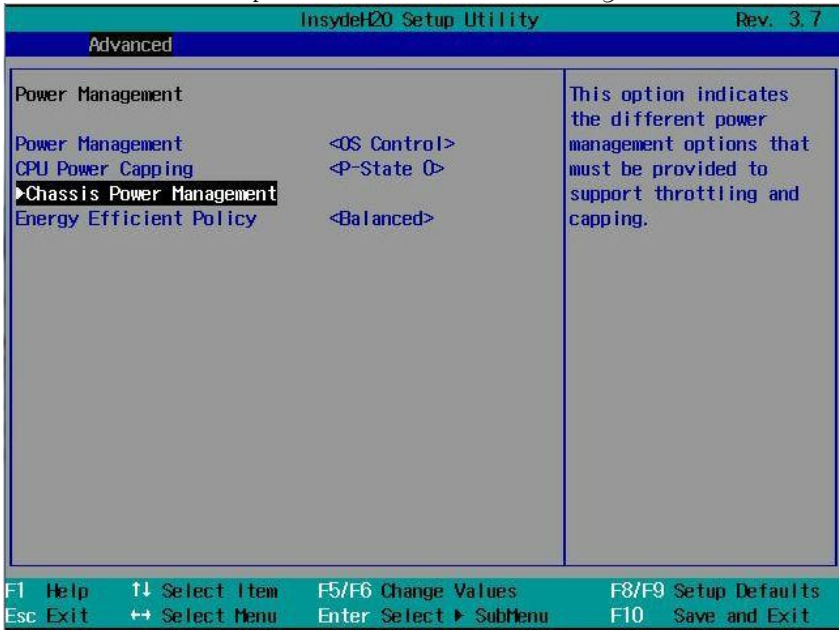

Option	Description
Power Management (OS Control default)	This field sets the System Power Management to Maximum Performance mode, OS Control mode, or Node Manager mode.
CPU Power Capping (P-state 0 default)	This option can decide the highest performance P-state in OS. This setting only can be seen when “Power Management” be selected to “OS Control” mode.
Chassis Power Management	This option indicates the different power management options that must be provided to support throttling and capping.
Energy Efficient Policy (Balanced default)	This field sets the Energy Efficient Policy to Maximum Performance mode, Balanced mode, or Low Power mode.

Option	Description
	This option works while the OS is not supported power management control of processor only.

Chassis Power Management

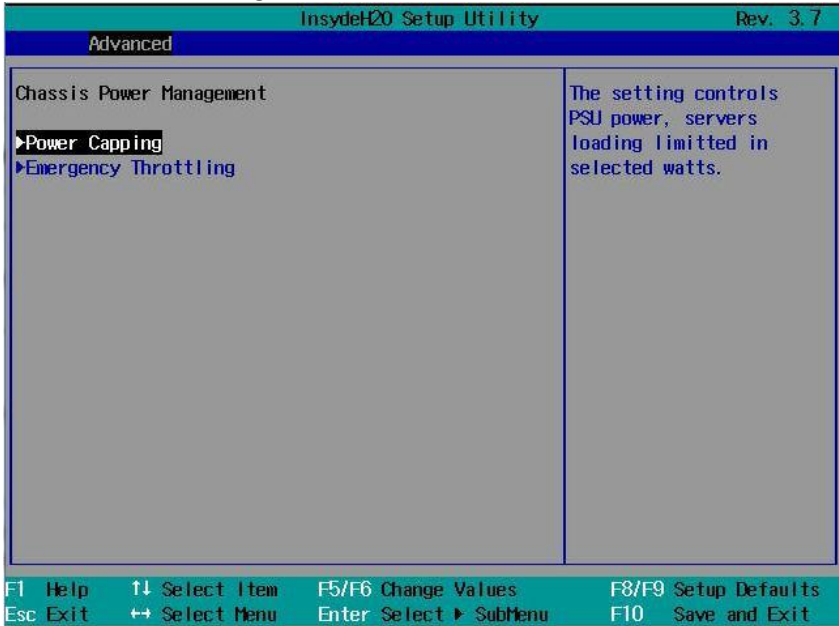

Option	Description
Power Capping	The setting controls PSU power, servers loading limited in selected watts.
Energy Throttling	This is the policy to take effect when the server detects a PSU emergency failure.

CPU Configuration

Scroll to this item and press **Enter** to view the following screen:

Advanced InsydeH2O Setup Utility Rev. 3.7

CPU Configuration

Genuine Intel(R) CPU @ 2.00GHz
Family 6, Model 2D, Stepping 2
64-Bit YES
Processor Speed 2000 MHz
Bus Speed 100 MHz
Level 2 Cache 1536 KB
Level 3 Cache 15360 KB
Processor Core 6
Installed CPU1
Installed CPU2

Active Processor Cores **<ALL Cores>**
Frequency Ratio <Auto>
Max CPUID Value Limit <Disabled>
Virtualization Technology <Disabled>
QPI Frequency <Auto>
Turbo Mode <Enabled>

This field controls the number of enabled cores in each processor.

By default, the maximum number of cores per processor will be enabled.

F1 Help ↑↓ Select Item F5/F6 Change Values F9 Setup Defaults
Esc Exit ↔ Select Menu Enter Select ▶ SubMenu F10 Save and Exit

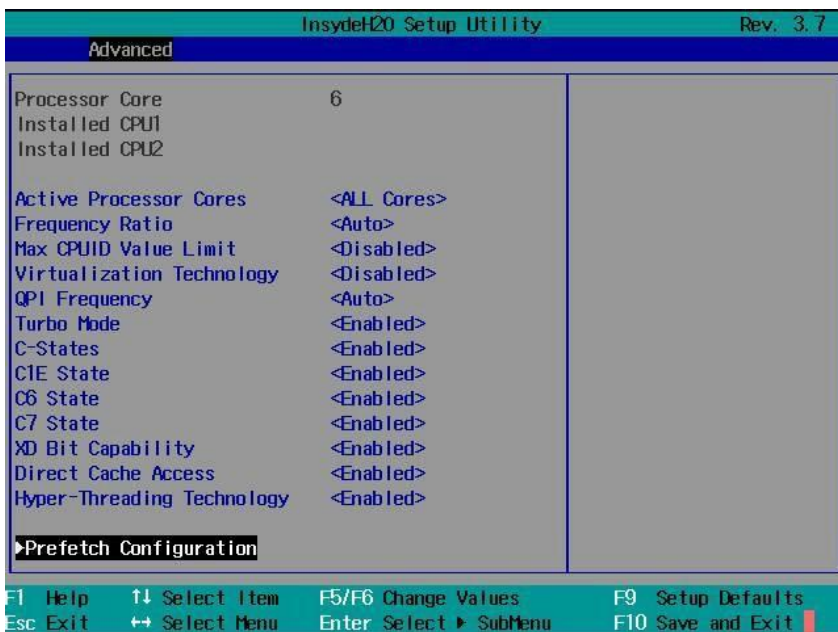

Option	Description
Active Processor Cores (All Cores default)	This field controls the number of enabled core in each processor.
Frequency Ratio (Auto default)	Sets frequency multiplier as maximum level. Downgrade- set multiplier 1~3 levels.
Max CPUID Value Limit (Disabled default)	Some OS, which is (NT4), fails if the value returned in EAX is >3 when CPUID instruction is executed with EAX=0. Disabled - this setting disables the 3 or less. Enabled - this setting limits CPUID function to 3
Virtualization Technology (Disabled default)	Enabled (applicable processors) / Disabled (unusable in any OS). This feature allows the users to set the VT technology in applicable processors.
QPI Frequency (Auto default)	Selects link speed: 6.4GTs/7.2GTs/8.0GTs

Option	Description
Turbo Mode (Enabled default)	Enables processor Turbo Mode (requires EMTTM enabled too.)
C-States (Enabled default)	Enabled - The processor can operate in all available Power C States. Disabled - There are no C States available for the processor.
C1E State (Enabled default)	Enabled - The C1-E is enabled by default. Disabled - The C1-E is disabled by users in their own liability. There are warning messages in both the BIOS Setup help text and the pop up message when the option is changing.
C6 State (Enabled default)	Enabled - The C6 is disabled by default. Disabled - The C6 is disabled by user in their own liability. There will be warning message in both the BIOS Setup help text and the pop up message when the option is changing.
C7 State (Enabled default)	Enabled-The C7 is enabled by default. Disabled-The C7 is disabled by users in their own liability. There will be warning message in both the BIOS Setup help text and the pop up message when the option is changing.
XD Bit Capability (Enabled default)	Intel processors that support the eXecute Disabled (XD) feature will Enable/ Disable report the support to the operating system. If the operating system supports this extended paging mechanism, it will provide sum.
Direct Cache Access (Enabled default)	Enables/Disables the Direct Cache Access.

Option	Description
Hyper Threading Technology (Enabled default)	Enables/Disables Hyper-Threading Technology.
CPU RAPL Big Dial (Scorpion, Nemo only) (Off default)	Sets off to disable CPU RAPL feature. Power Limit (Watt#) = CPU RAPL Big Dial – CPU RAPL Small Dial.
CPU RAPL Small Dial (Scorpion, Nemo only) (0 default)	Power Limit (Watt#) = CPU RAPL Big Dial – CPU RAPL Small Dial.
Prefetch Configuration	Configures Prefetch. (Invisible if CPU do not support.)

Prefetch Configuration

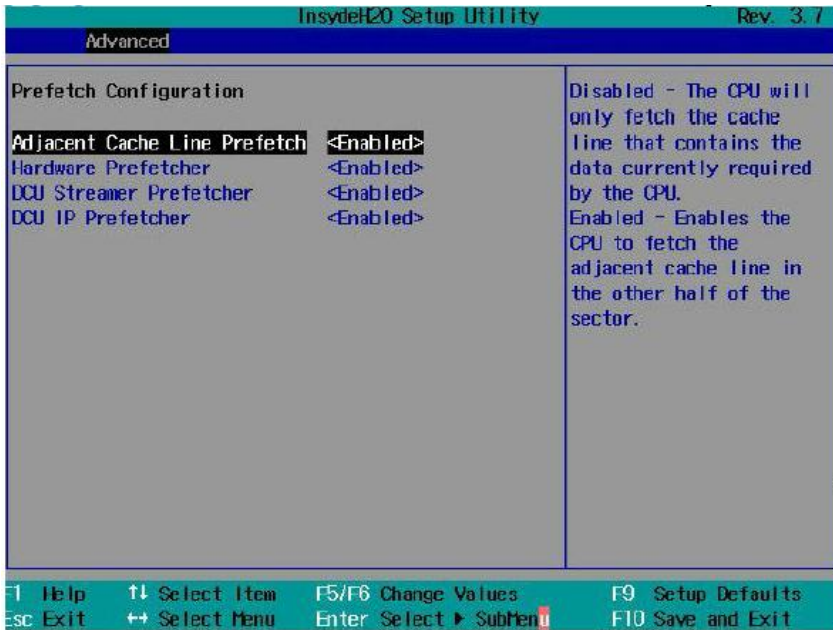

Option	Description
Adjacent Cache Prefetch (Enabled default)	Includes MLC Spatial Prefetcher. Disabled - The processor will only fetch the cache line that contains the data currently required by processor. Enabled - Enables the processor to fetch the adjacent cache line in the other half of the sector.
Hardware Prefetcher (Enabled default)	Includes MLC Streamer Prefetcher. Enables/ Disables the Hardware Prefetcher.
DCU Streamer Prefetcher (Enabled default)	This field enables/ disables the DCU Streamer Prefetcher. (Invisible if CPU do not support.)
DCU IP Prefetcher (Enabled default)	This field enables/ disables the DCU IP Prefetcher. (Invisible if CPU do not support.)

Memory Configuration

Scroll to this item and press **Enter** to view the following screen:

Advanced		InsydeH2O Setup Utility		Rev. 3.7
Memory Configuration				
System Available Memory Size	16384 MB			
System Memory Installed Size	16384 MB			
System Memory Type	DDR3			
System Memory Speed	1333 MHz			
System Memory Voltage	1.35V			
Memory Frequency	<Auto>			
Memory Throttling Mode	<Enabled>			
Memory Operating Mode	<Optimizer Mode>			
Demand Scrubbing	<Enabled>			
Patrol Scrubbing	<Enabled>			
Memory Operating Voltage	<Auto>			
NUMA Support	<Enabled>			
Memory-Mapped I/O	<Auto>			
Memory Refresh Rate	<X1>			
F1 Help	↑↓ Select Item	F5/F6 Change Values	F8/F9 Setup Defaults	
Esc Exit	↔ Select Menu	Enter Select ▶ SubMenu	F10 Save and Exit	

Option	Description
Memory Frequency (Auto default)	Memory frequency selections in MHz.
Memory Throttling Mode (Enabled default)	Sets memory running as closed loop thermal throttling. Set to support memory throttling to optimize power/acoustics.
Memory Operating Mode (Optimizer Mode default)	Memory operating mode is set to support Optimizer/Sparing/Memory mirroring/Advanced ECC.
Demand Scrubbing (Enabled default)	To disable or enable dram scrubbing is the ability to write corrected data back to the memory once a correctable error is detected on read transaction.
Patrol Scrubbing (Enabled default)	To disable or enable patrol scrubbing proactively searching the system memory, repairing correctable error.

Option	Description
Memory Operating Voltage (Auto default)	<p>Auto – this setting indicates the memory operating voltage will be set automatically by the memory initialization code and depends upon the installed DIMM's capability and the memory configuration of the system. This is the default setting and will set the Memory Operating Voltage to the POR voltage.</p> <p>1.5 V indicates all DIMMs in the system are operating at 1.5 volts.</p> <p>1.35 V indicates all DIMMs in the system are operating at 1.35 volts.</p> <p>1.25 V indicates all DIMMs in the system are operating at 1.25 volts.</p> <p>NOTE: BIOS will auto restrict selection if DIMM does not support low voltage.</p>
NUMA Support (Enabled default)	<p>Disabled – for BIOS setup to allow users enable the node interleave option. This is for NUMA systems that allow memory interleaving across all processor nodes.</p> <p>Enabled – for BIOS setup to allow users disable the node interleave option. This is for NUMA systems that allows memory interleaving across all processor nodes.</p>
Memory-Mapped I/O (Auto default)	<p>Auto - Supports PCI-E 32-bit BAR (base address register) in default and sets PCI-E 64-bit BAR automatically while PowerEdge C410x or Knights Corner GPU card are installed.</p> <p>32-bit – Forced to support PCI-E 32-bit BAR.</p> <p>64-bit – Forced to support PCI-E 64-bit BAR."</p>
Memory Refresh Rate (X1 default)	To disable or enable 2X refresh.

SATA Configuration

Scroll to this item and press **Enter** to view the following screen:

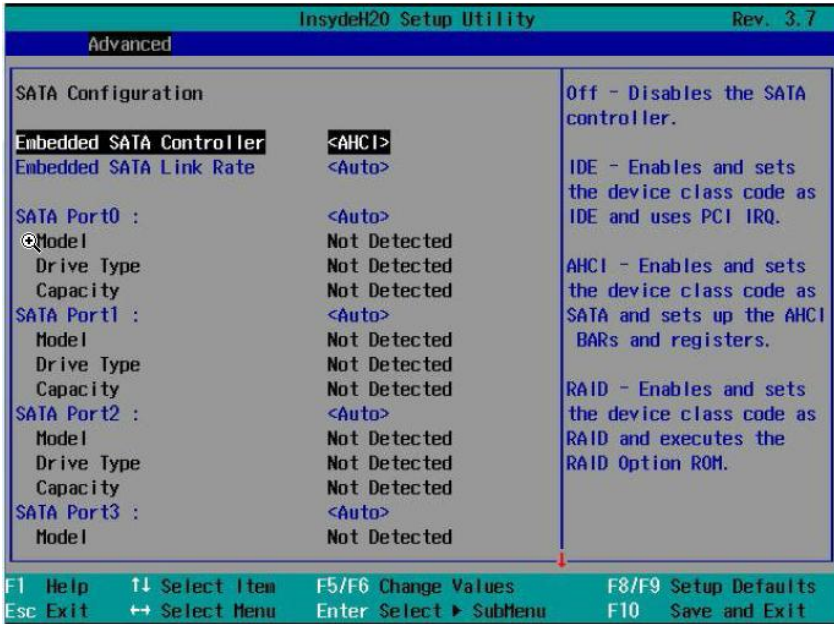

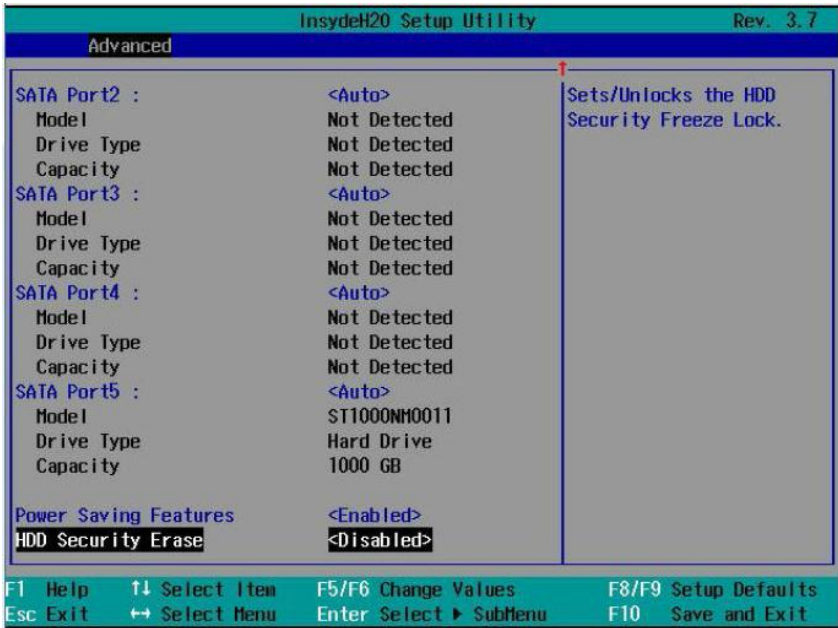

Option	Description
Embedded SATA Controller (AHCI default)	<p>Off – Disables the SATA controller. The token applies to the first on-board SATA controller.</p> <p>IDE – Enables the SATA controller. Sets the device class code as IDE and uses PCI IRQ (referred as Native mode). This token applies to the first on-board SATA controller.</p> <p>AHCI – Enables the SATA controller. Sets the device class code as SATA and sets up the AHCI BARs and registers. This token applies to the first on-board SATA controller.</p> <p>RAID – Enables the SATA controller. Sets the device class code as RAID and executes the RAID Option ROM. This token applies to the first on-board SATA controller.</p>

Option	Description
Embedded SATA Link Rate (Auto default)	Auto – Sets the SATA link rate at maximum. 1.5 Gbps – Sets the SATA link rate at minimum as 1.5 Gbps. For power consumption. 3.0 Gbps – Sets the SATA link rate at minimum as 3.0 Gbps.
SATA Port 0 (Auto default)	Off – Sets the 1st Serial ATA drive controller to Off. Auto – Sets the 1st Serial ATA drive controller to Auto (enabled if present, POST error if not present).
SATA Port 1 (Auto default)	Off – Sets the 2nd Serial ATA drive controller to Off. Auto – Sets the 2nd Serial ATA drive controller to Auto (enabled if present, POST error if not present).
SATA Port 2 (Auto default)	Off – Sets the 3rd Serial ATA drive controller to Off. Auto – Sets the 3rd Serial ATA drive controller to Auto (enabled if present, POST error if not present).
SATA Port 3 (Auto default)	Off – Sets the 4th Serial ATA drive controller to Off. Auto – Sets the 4th Serial ATA drive controller to Auto (enabled if present, POST error if not present).
SATA Port 4 (Auto default)	Off – Sets the 5th Serial ATA drive controller to off. Auto – Sets the 6th Serial ATA drive controller to Auto (enabled if present, POST error if not present).
SATA Port 5 (Auto default)	Off – Sets the 6th Serial ATA drive controller to off. Auto – Sets the 6th Serial ATA drive controller to Auto (enabled if present, POST error if not present).
Power Saving Features (Enabled default)	This feature will allow users to disable/enable the feature that allows SATA HDDs to initiate link power management transitions.
HDD Security Erase (Disabled default)	Sets/Unlocks the HDD Security Freeze Lock.

PCI Configuration

Scroll to this item and press **Enter** to view the following screen:

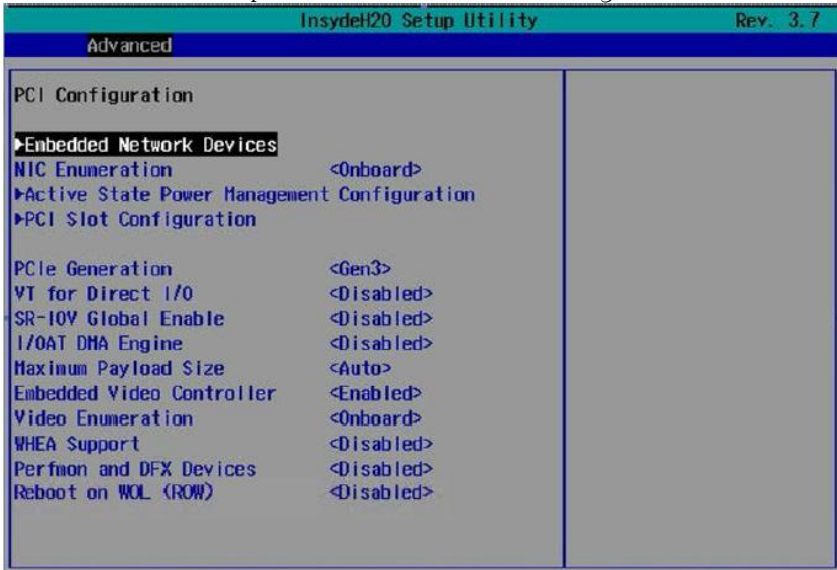

NOTE: The PCI-E Gen2 x16 slot 1 and slot 2 are supported up to Gen2 5.0 Gigabits bandwidth. If user inserts Gen3 .0 devices into the 2 slots that will only train at Gen 2.0 speed, not Gen 3.0.

Option	Description
Embedded Network Devices	Configure embedded network devices.
NIC Enumeration (Onboard default)	Onboard – Default. Sets PXE boot from on-board NIC then Add-on NIC adapter. Add-in – Sets PXE boot from Add-on NIC adapter then on-board NIC.
Active State Power Management Configuration	To control Active State Power Management (ASPM).
PCI Slot Configuration	Configures PCI add-in card.
PCIe Generation (Gen3 default)	Sets the PCI signaling rate at Gen3 8.0/Gen2 5.0/Gen1 2.5 Gigabits bandwidth.

VT for Direct I/O (Disabled default)	Enables/Disables I/O VTd Error.
SR-IOV Global Enable (Disabled default)	Enables/Disables BIOS support for SRIOV devices.
I/OAT DMA Engine (Disabled default)	Enables/Disables the I/O Acceleration Technology (I/OAT) DMA Engine option. This feature should be enabled only if the hardware and software support I/OAT.
Maximum Payload Size (Auto default)	Auto – Auto detects the PCI-E maximum payload size. 128 Bytes – Sets the PCI-E maximum payload size to 128 Bytes. 256 Bytes – Sets the PCI-E maximum payload size to 256 Bytes.
Embedded Video Controller (Enabled default)	Enabled - The embedded video controller is enabled, and it is the primary video device. Disabled - The embedded video controller is disabled.
Video Enumeration (Onboard default)	Onboard - The onboard video controller is used for boot-time messages. Add-in - The first add-in video controller is used for boot-time messages. Depending on the BIOS search order and system slot layout.
WHEA Support (Disabled default)	Disables/Enables Windows Hardware Error Architecture
Perfmon and DFX Devices (Disabled default)	Selects enabled if devices 8 and 9, function2 and 6 if CPUBUSN(0) are desired to be visible.
Reboot on WOL (ROW) (Disabled default)	Reboot On WOL targeted at network controllers when network controller receives a magic packet. Note: Reboot on WOL feature is opened by customized, need EEPROM supported.

Embedded Network Devices

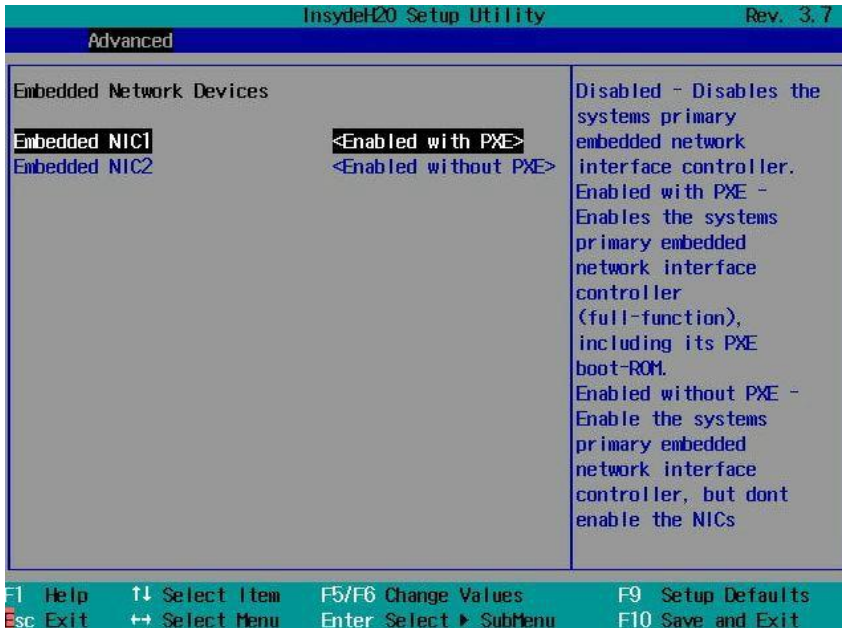

Option	Description
Embedded NIC1 (Enabled with PXE default)	<p>Disabled – Disables the system’s primary embedded network interface controller.</p> <p>Enabled with PXE – Enables the system’s primary embedded network interface controller (full-function), including its PXE boot-ROM.</p> <p>Enabled without PXE – Enables the system’s primary embedded network interface controller, but don’t enable the NIC’s associated PXE or RPL boot-ROM.</p> <p>iSCSI Remote Boot – Enables NIC1 with iSCSI Remote Boot.</p>

Option	Description
Embedded NIC2 (Enabled without PXE default)	<p>Disabled – Disables the system’s secondary embedded network interface controller.</p> <p>Enabled with PXE – Enables the system’s secondary embedded network interface controller (full-function), including its PXE boot-ROM.</p> <p>Enabled without PXE – Enables the system’s secondary embedded network interface controller, but don’t enable the NIC’s associated PXE or RPL boot-ROM.</p> <p>iSCSI Remote Boot – Enables NIC2 with iSCSI Remote Boot.</p>

ISCSI Remote Boot

Advanced		InsydeH2O Setup Utility	Rev. 3.7
iSCSI Configuration		Embedded NIC 1	The worldwide unique name of the initiator. Only iqn. format is accepted.
iSCSI Initiator Name	<Unknow>		
Enable DHCP	<Disabled>		
Initiator IP Address	0.0.0.0		
Initiator Subnet Mask	0.0.0.0		
Gateway	0.0.0.0		
Target Name	<Unknow>		
Target IP Address	0.0.0.0		
Target Port	[3260]		
Boot LUN	0		
CHAP Type	<None>		
F1 Help	↑↓ Select Item	F5/F6 Change Values	F9 Setup Defaults
Esc Exit	↔ Select Menu	Enter Select ▶ SubMenu	F10 Save and Exit

Option	Description
iSCSI Initiator Name	The worldwide unique name if the uninitiator. Only iqn format is accepted.
Enable DHCP (Disabled default)	Disables/Enables DHCP.
Initiator IP Address Initiator Subnet Mask Gateway	Enters IP address in dotted-decimal notation.
Target IP Target IP Address Target Port Boot LUN	Targets Name Enters IP address in dotted-decimal notation Targets Port Hexadecimal representation of LU number
CHAP Type (None default)	None, one way CHAP or mutual CHAP.

Active State Power Management Configuration

InsydeH2O Setup Utility		Rev. 3.7
Advanced		
Active State Power Management Configuration		
PCIe Slot ASPM	<Disabled>	<p>Disabled - Controls the level of ASPM supported on the PCI Express Link of port 2. All entry disabled.</p> <p>L0 - Controls the level of ASPM supported on the given PCI Express Link of port 2. L0s entry enabled.</p> <p>L1 - Controls the level of ASPM supported on the given PCI Express Link of port 2. L1 entry enabled.</p>
Onboard LAN ASPM	<Disabled>	
Mezzanine Slot ASPM	<Disabled>	
NB-SB Link ASPM	<L1>	
F1 Help	↑↓ Select Item	F5/F6 Change Values
Esc Exit	↔ Select Menu	Enter Select ▶ SubMenu
		F9 Setup Defaults
		F10 Save and Exit

Option	Description
PCIe Slot ASPM (Disabled default)	<p>Disabled - Controls the level of ASPM supported on the PCI-E Link of port 2. All entry is disabled.</p> <p>L1 - Controls the level of ASPM supported on the given PCI-E Link of port 2. L1 entry is enabled.</p>
Onboard LAN ASPM (Disabled default)	<p>Disabled - Controls the level of ASPM supported on the PCI-E Link of port4. All entry is disabled.</p> <p>L1 - Controls the level of ASPM supported on the given PCI-E Link of port4. L1 entry is enabled.</p>
Mezzanine Slot ASPM	<p>Disabled - Controls the level of ASPM supported on the PCI-E Link of port11. All entry is disabled.</p>

Option	Description
(Disabled default)	L1 - Controls the level of ASPM supported on the given PCI-E Link of port11. L1 entry is enabled.
NB-SB Link ASPM (L1 default)	Disabled - Controls the level of ASPM supported on the NB-SB. All entry is disabled. L1 - Controls the level of ASPM supported on the NB-SB. L1 entry is enabled.

PCI Slot Configuration

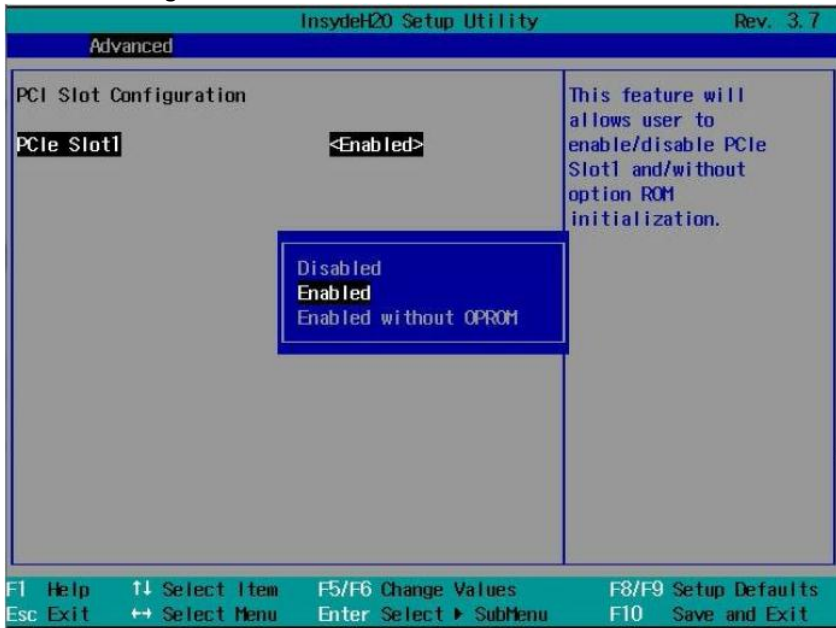

Option	Description
PCIe Slot (Enabled default)	This feature will allow user to enable/disable PCI-E Slot and without option ROM initialization.

USB Configuration

Scroll to this item and press **Enter** to view the following screen:

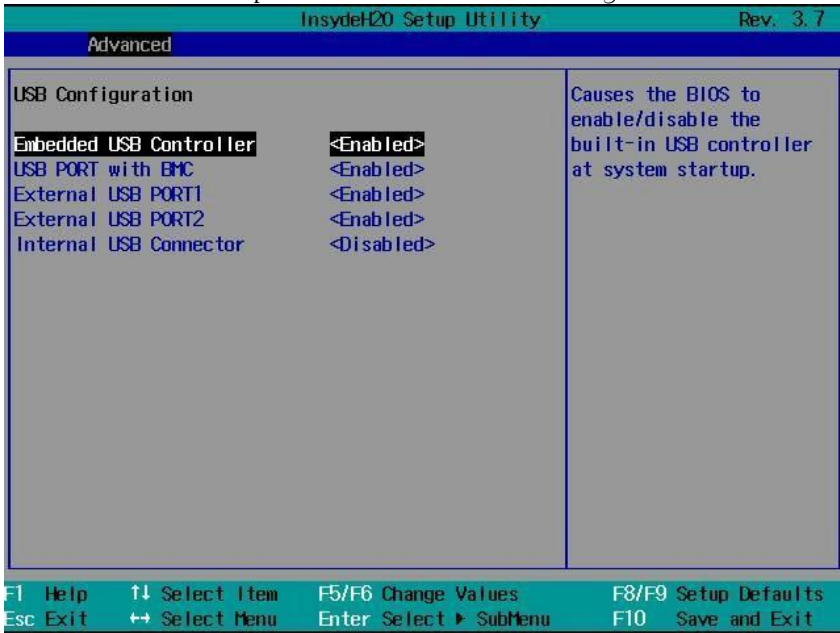

Option	Description
Embedded USB Controller (Enabled default)	Causes the BIOS to enable/disable the built-in USB controller at system startup.
USB Port with BMC (Enabled default)	This feature allows the users to electrically disable / enable the internal USB port which contacts to BMC.
External USB Port1 (Enabled default)	This feature allows the users to electrically disable / enable the external USB port 1.
External USB Port2 (Enabled default)	This feature allows the users to electrically disable/ enable the external USB port 2.
Internal USB Connector (Enabled default)	This field disables/enables the internal USB port.

Security Menu

This page enables you to set the security parameters. Scroll to this item and press **Enter** to view the following screen:



Option	Description
Supervisor Password	Displays whether the supervisor password is installed or not.
User Password	Displays whether the user password is installed or not.
Change Supervisor Password	Installs or changes the password.
Change User Password	Installs or changes the password.



Option	Description
Change Supervisor Password	Install or change the password.
Password Check (Setup default)	Always: System will ask input password on POST time. Setup: System will ask input password when goes to Setup utility.
User Access Level (Limited default)	Limited: Only limited fields can be changed. No Access: Prevent user access to setup utility. View Only: Access to setup utility allowed but the fields cannot be changed. Full: Any field can be changed except the Supervisor password.
Change User Password	Installs or changes the password and the length of password must be greater than one character.
Clear User Password	Clears User Password.

Server Menu

This page enables you to configure Server parameters. Scroll to this item and press **Enter** to view the following screen:

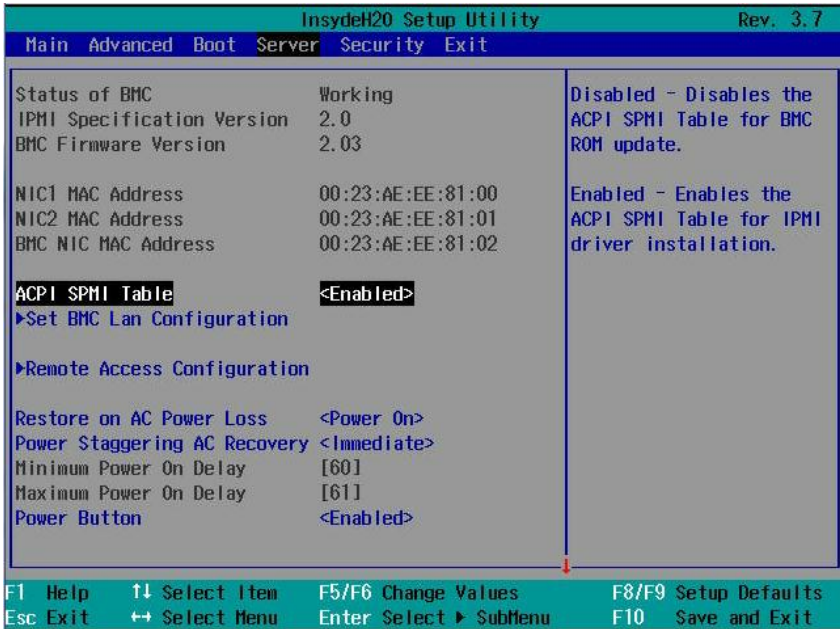

Option	Description
Status of BMC	Displays the BMC status.
IPMI Specification Version	Displays the IPMI specification version.
BMC Firmware Version	Displays the BMC firmware version.
NIC1 MAC Address	Displays the NIC1 MAC address.
NIC2 MAC Address	Displays the NIC2 MAC address.

Option	Description
BMC NIC MAC Address	Displays the MAC address for the BMC NIC connector.
ACPI SPMI Table (Enabled default)	Disabled – Disables the ACPI SPMI Table for BMC ROM update. Enabled – Enables the ACPI SPMI Table for IPMI driver installation.
Set BMC LAN Configuration	Inputs for Set LAN Configuration command. Each item in this group may take considerable amount of time.
Remote Access Configuration	Configures Remote Access.
Restore on AC Power Loss (Power On default)	Power Off - After an AC power loss, when AC power is restored, the system will stay off. Power On - After an AC power loss, when AC power is restored, the system will power on. Last State - After an AC power loss, when AC power is restored, the system will return to the state which is when power was lost.
Power Staggering AC Recovery (Immediate default)	Sets the Power Staggering AC Recovery time to immediate/Random/User Defined mode.
Power Button (Enabled default)	Enabled - Default, Enables Power Button to turn off system. Disabled - Disables Power Button to turn off system.
View System Event Log	Views all events in the BMC and BIOS event Log.
Event Logging (Enabled default)	Disables/Enables BIOS to log system events to BMC, errors include ECC/ PCI/ PCI-E/ HT...etc.
NMI on Error (Enabled default)	Disables/Enables BIOS to generate NMI when PCI-E uncorrectable errors occur.

Set BMC LAN Configuration

Select Set BMC LAN Configuration to view the following submenu:

InsydeH2O Setup Utility		Rev. 3.7
Server		
Set BMC Lan Configuration		Sets BMC LAN Port to Dedicated-NIC or Shared-NIC.
Channel Number	1	
Channel Number Status	OK	
BMC Lan Port Configuration	<Shared-NIC>	
BMC NIC IP Source	<DHCP>	
IP Address	192.168.1.3	
Subnet Mask	255.255.255.0	
GateWay Address	0.0.0.0	
GateWay MAC Address	00:00:00:00:00:00	
BMC NIC MAC Address	00:C0:A8:12:34:56	
IPv6 Mode	<Disabled>	
F1 Help	↑↓ Select Item	F5/F6 Change Values
Esc Exit	↔ Select Menu	Enter Select ▶ SubMenu
		F8/F9 Setup Defaults
		F10 Save and Exit

Option	Description
Channel Number	Displays the channel number.
Channel Number Status	Displays the channel number status.
BMC LAN Port Configuration (Shared-NIC default)	Sets BMC LAN Port to dedicated-NIC or shared-NIC.
BMC NIC IP Source (DHCP default)	Sets BMC LAN to get LAN IP from Static/ DHCP mode.
IP Address	Sets BMC LAN IP address.
Subnet Mask	Sets BMC LAN subnet mask.
Gateway Address	Sets BMC LAN Gateway address.
IPv6 Mode (Disabled default)	Enables or disables IPv6 internet protocol support.

Remote Access Configuration

Select Remote Access Configuration to view the following submenu:

InsydeH2O Setup Utility		Rev. 3.7
Server		
Remote Access Configuration		Disabled - Serial Console Redirection Off. Enabled - Enables Serial Console Redirection.
Remote Access	<Enabled>	
Serial port number	<COM2 as SQL>	
Current SQL Baud Rate	115200 bps	
Serial Port Address	<3F8h/2F8h>	
Serial Port Mode	<115200 8,n,1>	
Flow Control	<None>	
Redirection After BIOS POST	<Always>	
Terminal Type	<ANSI>	
VT-UTF8 Combo Key Support	<Enabled>	

F1 Help ↑ Select Item F5/F6 Change Values F9 Setup Defaults
Esc Exit ↔ Select Menu Enter Select ► SubMenu F10 Save and Exit

Option	Description
Remote Access (Enabled default)	Disabled - Serial Console Redirection Off. Enabled - Enables Serial Console Redirection.
Serial Port Number (COM2 as SOL default)	COM1- serial Console Redirection On, output to COM1. See also token D7h. COM2 as SOL-serial Console redirection On, output to COM2.
Serial Port Address (3F8h/2F8h default)	3F8h/2F8h - By default, set rear serial port address as 0x3F8 and internal serial port address as 0x2F8. 2F8h/3F8h - Set rear serial port address as 0x2F8 and internal serial port address as 0x3F8.
Serial Port Mode (115200 8, n, 1 default)	Console Redirection baud rate will be set to 115,200/ 57,600/ 38,400/ 19,200/ 9,600 bits per second.
Flow Control (None default)	Remote access flowcontrols by none/ hardware/ software.
Redirection After BIOS POST (Always default)	Always - The BIOS console redirection, if enabled, continues to operate after the OS boot hand-off. Disabled - The BIOS console redirection, if enabled, operates during the BIOS boot only and is disabled prior to OS boot hand-off. See also tokens BFh, C0h, D7h, 401Ah and 401Bh.
Terminal Type (ANSI default)	The BIOS console redirection, if enabled, operates in VT100/VT-UTF8/ANSI emulation model. See also tokens BFh, C0h, and D7h.
VT-UTF8 Combo Key Support (Enabled default)	Enables or disables VT-UTF8 combination key support for ANSI/VT100 terminals.

Boot Menu

This page enables you to set POST boot parameters. Scroll to this item and press **Enter** to view the following screen:

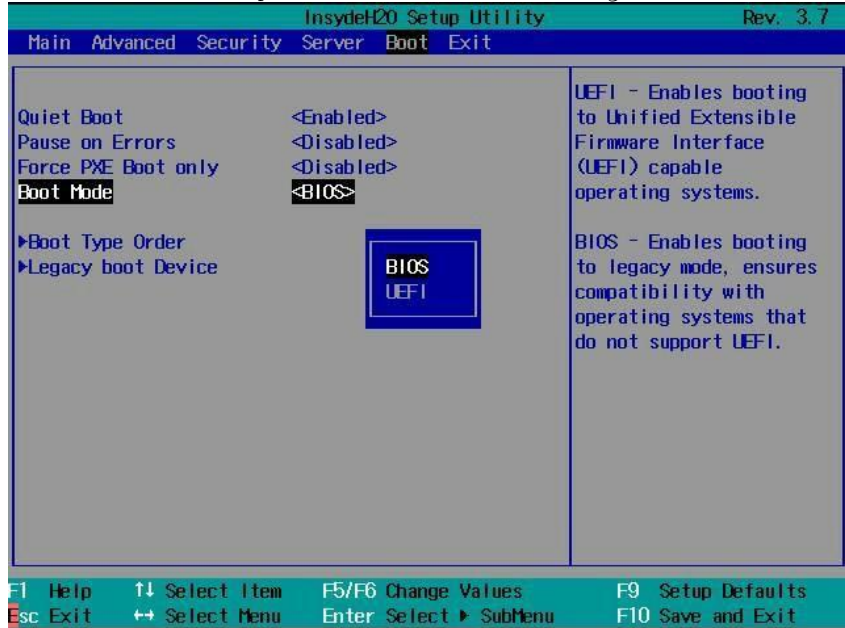

Option	Description
Quiet Boot (Enabled default)	Enabled – Enables the display of the splash or summary screen, rather than the detail of the POST flow. Disabled- Disables the display of the splash or summary screen. The user is able to see the detail of the POST messages.
Pause on Errors (Disabled default)	Enables/Disables the BIOS from prompting for F1/F2 on error. BIOS pauses at F1/F2 prompt.
Force PXE Boot Only (Disabled default)	Enables/Disables PXE to be the boot device only. The system retrying to boot from PXE device.

Option	Description
Boot Mode (BIOS default)	<p>UEFI –Enables booting to Unified Extensible Firmware Interface (UEFI).</p> <p>BIOS – Enables booting to Legacy mode, ensures compatibility with operating systems that do not support UEFI.</p>
Boot Type Order	Configures Boot Type Order, Network/ Hard Disk/ RAID/ USB Storage/ CD/ DVD ROM.

Exit Menu

Scroll to this item and press **Enter** to view the following screen:

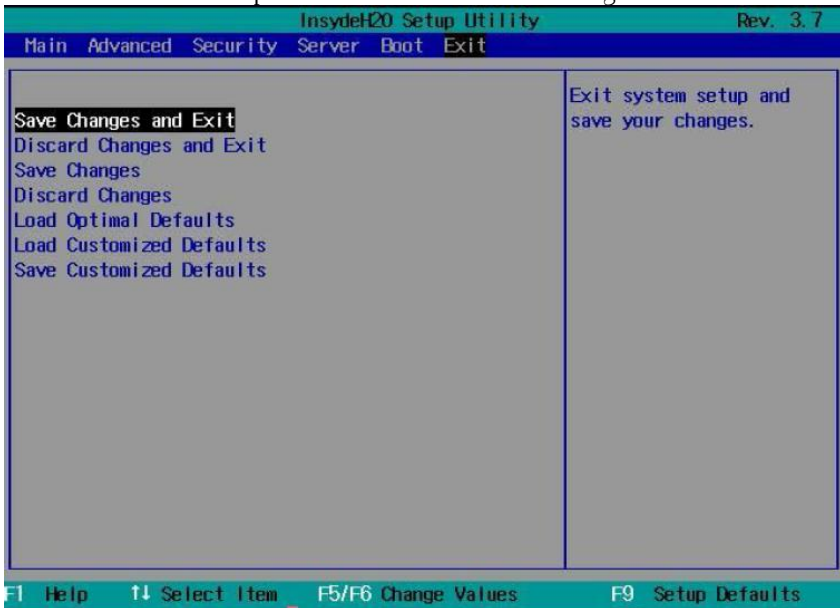

Option	Description
Save Changes and Exit	Exits system setup after saving the changes. F10 key can be used for this operation.
Discard Changes and Exit	Exist system setup without saving any changes. ESC key can be used for this operation.
Save Changes	Saves changes done so far to any of the setup questions.
Discard Changes	Saves Discards changes.
Load Optimal Defaults	Loads optimal default values for all the setup questions.
Load Customized Defaults	Loads Customized default values for all the setup questions.
Save Customized Defaults	Saves all setup questions' current values as Customized default.

Command Line Interfaces for Setup options

The options of SETUP menu allow the user to control by system configuration utility (syscfg), the utility includes in Dell OpenManage Deployment Toolkit (DTK).

Users can use the utility as following:

- To change the SETUP option by D4 token:
./syscfg -t=D4_token_id

(Example: ./syscfg -t=0x002D to enable NIC1)

- To check token active status:
./syscfg --istokenactive=D4_token_id
(Example: ./syscfg --istokenactive=0x002D to check the token active status of NIC1)
- To change the SETUP option thru BMC memory directly:
./ipmitool raw <command> <data>

(Example: `./ipmitool raw 0xc 1 1 3 10 106 42 120` to set IP address of BMC LAN port as 10.106.42.120)

Table 2-1. The D4 Token Table

Token	Setup option	Description
002D	Embedded NIC1	Enables the system's primary embedded network interface controller (full-function), including its PXE boot-ROM.
002E	Embedded NIC1	Disables the system's primary embedded network interface controller.
0051	N/A	For the next system boot, set the IPL priority to: USB storage, hard disk, CD/DVD-ROM, RAID, Network (if the devices are available)
0052	N/A	For the next system boot, set the IPL priority to: hard disk then option ROMs (if the devices are available)
0053	N/A	For the next system boot, set the IPL priority to: Network, hard disk, RAID,USB storage, CD/DVD-ROM (if the devices are available)
0054	N/A	For the next system boot, set the IPL priority to: CD/DVD-ROM, USB Storage, hard disk, RAID, Network (if the devices are available)
005C	N/A	Enables the BIOS remote update on the next reboot, to search for an operating-system initiated BIOS update image.
005D	N/A	Disables the BIOS remote update on the next reboot, to search for an operating-system initiated BIOS update image.
006E	Embedded NIC1	Enable the system's primary embedded network interface controller, but don't enable the NIC's associated PXE or RPL boot-ROM.
0087	Video Enumeration	The onboard video controller is used for boot-time messages.

Token	Setup option	Description
0088	Video Enumeration	The first add-in video controller is used for boot-time messages. Depending on the BIOS search order and system slot layout.
008C	Embedded USB Controller	Causes the BIOS to enable the built-in USB controller at system startup.
008D	Embedded USB Controller	Causes the BIOS to disable the built-in USB controller at system startup.
00A1	Restore on AC Power Loss	After an AC power loss, when AC power is restored, the system will stay off.
00A2	Restore on AC Power Loss	After an AC power loss, when AC power is restored, the system will return to the state was in when power was lost.
00A3	Restore on AC Power Loss	After an AC power loss, when AC power is restored, the system will power on.
00BA	Embedded NIC2	Disable the system's secondary embedded network interface controller.
00BB	Embedded NIC2	Enable the system's secondary embedded network interface controller, but don't enable the NIC's associated PXE or RPL boot-ROM.
00BC	Embedded NIC2	Enable the system's secondary embedded network interface controller (full-function), including its PXE boot-ROM.
00BF	Remote Access	Serial Console Redirection Off.
00C0	Serial port number	Serial Console Redirection On, output to COM1. See also token D7h.
00C1	Power Button	Default, Enables Power Button to turn off system.
00C2	Power Button	Disables Power Button to turn off system.
00D1	Hyper-Threading Technology	Enables Hyper-Threading Technology.
00D2	Hyper-Threading Technology	Disables Hyper-Threading Technology.

Token	Setup option	Description
00D7	Serial port Number	Serial Console redirection ON - output to COM2.
00D8	Load Optimal Defaults	Requests a optimal default of SETUP values on the next boot.
00FE	Legacy USB Support	System does not provide legacy USB support for operating system.
00FF	Legacy USB Support	System provides legacy USB support for operating system.
0117	SATA Port0	Sets the 1st Serial ATA drive controller to OFF.
0118	SATA Port0	Sets the 1st Serial ATA drive controller to Auto (enabled if present, POST error if not present).
0119	SATA Port1	Sets the 2nd Serial ATA drive controller to OFF.
011A	SATA Port1	Sets the 2nd Serial ATA drive controller to Auto (enabled if present, POST error if not present).
011B	SATA Port2	Sets the 3rd Serial ATA drive controller to OFF.
011C	SATA Port2	Sets the 3rd Serial ATA drive controller to Auto (enabled if present, POST error if not present).
011D	SATA Port3	Sets the 4th Serial ATA drive controller to OFF.
011E	SATA Port3	Sets the 4th Serial ATA drive controller to Auto (enabled if present, POST error if not present).
011F	SATA Port4	Sets the 5th Serial ATA drive controller to OFF.
0120	SATA Port4	Sets the 5th Serial ATA drive controller to Auto (enabled if present, POST error if not present).
0121	SATA Port5	Sets the 6th Serial ATA drive controller to OFF.
0122	SATA Port5	Sets the 6th Serial ATA drive controller to Auto (enabled if present, POST error if not present).
0135	Embedded SATA Controller	Disables the SATA controller. The token applies to the first on-board SATA controller.

Token	Setup option	Description
0137	Embedded SATA Controller	Enables the SATA controller. Sets the device class code as IDE and uses PCI IRQ (referred as Native mode). This token applies to the first on-board SATA controller.
0138	Embedded SATA Controller	Enables the SATA controller. Sets the device class code as SATA and sets up the AHCI BARs and registers. This token applies to the first on-board SATA controller.
0139	Embedded SATA Controller	Enables the SATA controller. Sets the device class code as RAID and executes the RAID Option ROM. This token applies to the first on-board SATA controller.
013E	Memory Remapping (3GB~4GB)	Memory remapping relocates memory space behind PCI hole to the space above 4G with this feature disabled.
013F	Memory Remapping (3GB~4GB)	Memory remapping relocates memory space 3G~4G to the space above 4G with this feature enabled.
0140	Execute-Disable (XD) Bit Capability	When disabled, Intel processors that support the eExecute Disable (XD) feature will not report the support to the operating system.
0141	Execute-Disable (XD) Bit Capability	When enabled, Intel processors that support the eExecute Disable (XD) feature will report the support to the operating system. If the operating system supports this extended paging mechanism, it will provide some protection against software viruses that exploit buffer overflows.
014A	Virtualization Technology	This feature will allow the users to disable the VT technology in applicable processors. If disabled, the VT feature is unusable in any OS.
014B	Virtualization Technology	This feature will allow the users to enable the VT technology in applicable processors.
014E	External USB PORT1	This feature will allow the users to electrically disable the external USB port1.
014F	External USB PORT1	This feature will allow the users to electrically enable the external USB port1.
0168	Max CPUID Value Limit	Some OS's (NT4) will fail if the value returned in EAX is > 3 when CPUID instruction is executed with EAX=0. This setting disables the 3 or less.

Token	Setup option	Description
0169	Max CPUID Value Limit	Some OS's (NT4) will fail if the value returned in EAX is > 3 when CPUID instruction is executed with EAX=0. This setting will limit CPUID function to 3.
016F	Embedded SAS Controller	Disables the SAS controller. The token applies to on-board SAS controller
0170	Embedded SAS Controller	Enables the SAS controller. Sets the device class code as AHCI/RAID and executes the RAID Option ROM. This token applies to on-board SAS controller.
0171	Adjacent Cache Line Prefetch	The processor will only fetch the cache line that contains the data currently required by the processor.
0172	Adjacent Cache Line Prefetch	Enables the processor to fetch the adjacent cache line in the other half of the sector.
0173	Hardware Prefetcher	Disables the processor's HW prefetcher.
0174	Hardware Prefetcher	Enables the processor' HW prefetcher.
0178	Remote Access	Enables Serial Console Redirection.
0189	External USB PORT2	This feature will allow the users to electrically disable the external USB port2.
018A	External USB PORT2	This feature will allow the users to electrically enable the external USB port2.
0199	Power Saving Features	This feature will allow users to disable the feature that allows SATA HDDs to initiate link power management transitions.
019A	Power Saving Features	This feature will allow users to enable the feature that allows SATA HDDs to initiate link power management transitions.
01C4	NUMA Support	For BIOS Setup to allow user enable the node interleave option. This is for NUMA systems that allow memory interleaving across all processor nodes.
01C5	NUMA Support	For BIOS Setup to allow user disable the node interleave option. This is for NUMA systems that allow memory interleaving across all processor nodes.

Token	Setup option	Description
01CF	I/OAT DMA Engine	Enables the I/O Acceleration Technology (I/OAT) DMA Engine option. This feature should be enabled only if the hardware and software support I/OAT.
01D0	I/OAT DMA Engine	Disables the I/O Acceleration Technology (I/OAT) DMA Engine option. This feature should be disabled only if the hardware and software support I/OAT.
01DA	Embedded NIC1	Enables NIC1 with iSCSI Remote Boot.
01DB	Embedded NIC2	Enables NIC2 with iSCSI Remote Boot.
01EA	Turbo Mode	Disables Intel's processor allows the processor core to increase its frequency.
01EB	Turbo Mode	Enables Intel's processor allows the processor core to increase its frequency.
01F0	Embedded NIC3	Disables the system's third embedded network interface controller.
01F1	Embedded NIC3	Enables the system's third embedded network interface controller, but don't enable the NIC's associated PXE or RPL boot-ROM.
01F2	Embedded NIC3	Enables the system's third embedded network interface controller (full-function), including its PXE boot-ROM.
01F3	Embedded NIC3	Enables NIC3 with iSCSI Remote Boot.
0204	VT for Direct I/O	Disables Intel Virtualization Technology for Direct I/O (VT-d) that enhances I/O support (DMA) when running a Virtual Machine Monitor.
0205	VT for Direct I/O	Enables Intel Virtualization Technology for Direct I/O (VT-d) that enhances I/O support (DMA) when running a Virtual Machine Monitor.
0211	Internal USB PORT	This field disables the internal USB port.
0212	Internal USB PORT	This field enables the internal USB port.
021F	Maximum Performance	This will set the Maximum Performance mode in the system.
0221	OS Control	Allows OS to change the P-state.

Token	Setup option	Description
0224	Embedded Video Controller	The embedded video controller is enabled, and it is the primary video device.
0225	Embedded Video Controller	The embedded video controller is disabled.
022D	Boot Mode	Enables booting to Unified Extensible Firmware Interface (UEFI) capable operating systems.
022E	Boot Mode	Enables booting to legacy mode, ensures compatibility with operating systems that do not support UEFI.
0231	Active Processor Cores	All four cores of the processor are enabled. This is applicable for Quad-core processor only.
0232	Active Processor Cores	Two cores of the processor are enabled. This is applicable for Quad-core and Dual-core processors.
0233	Active Processor Cores	Single core of the processor is enabled. This is applicable for Quad-core and Dual-Core processors.
024B	C States	Sets to enable (default), the processor can operate in all available Power C States.
024C	C States	Sets to disable, there are no C states available for the processor.
024D	Pause on Errors	Enables the BIOS from prompting for F1/F2 on error. BIOS pauses at F1/F2 prompt.
024E	Pause on Errors	Disables the BIOS from prompting for F1/F2 on error. BIOS pauses at F1/F2 prompt
024F	Quiet Boot	Enables the display of the splash or summary screen, rather than the detail of the POST flow.
0250	Quiet Boot	Disables the display of the splash or summary screen. The user is able to see the detail of the POST messages.
0251	N/A	The first NIC is used for PXE boot, followed by NIC2.
0252	N/A	The second NIC is used for PXE boot, followed by NIC1.
0254	3F8h/2F8h	By default, set rear serial port address as 0x3F8 and internal serial port address as 0x2F8.

Token	Setup option	Description
0257	2F8h/3F8h	Set rear serial port address as 0x2F8 and internal serial port address as 0x3F8.
025D	Optimizer Mode	Memory Operating Mode set to support Optimizer.
025E	Spare Mode	Memory Operating Mode set to support Sparing.
025F	Mirror Mode	Memory Operating Mode set to support Memory mirroring.
0260	Advanced ECC Mode	Memory Operating Mode set to support Advanced ECC, i.e. Lockstep, Chipkill.
026A	Coherent HT Link Speed	Sets to support HyperTransport 1 specification.
026B	Coherent HT Link Speed	Sets to support HyperTransport 3 specification.
026E	Active Processor Cores	This field controls the number of enabled all of cores in each processor. By default, the maximum number of cores per processor will be enabled.
026F	Active Processor Cores	This field controls the number of enabled 6 cores in each processor. By default, the maximum number of cores per processor will be enabled.
0270	Active Processor Cores	This field controls the number of enabled 8 cores in each processor. By default, the maximum number of cores per processor will be enabled.
0271	Active Processor Cores	This field controls the number of enabled 10 cores in each processor. By default, the maximum number of cores per processor will be enabled.
0272	Active Processor Cores	This field controls the number of enabled 12 cores in each processor. By default, the maximum number of cores per processor will be enabled.
027B	HT Assist	Allows user the ability to disable the Probe Filter chipset option from BIOS setup. There are some applications that may have lower performance with the chipset feature enabled.
027C	HT Assist	Allows user the ability to enable the Probe Filter chipset option from BIOS setup. There are some applications that may have lower performance with the chipset feature disabled.

Token	Setup option	Description
02A1	C1E State	The C1-E is enabled by default.
02A2	C1E State	The C1-E is disabled by user in their own liability. There will be warning message in both the BIOS Setup help text and the pop up message when the option is changing.
02A9	DRAM Prefetcher	Disables DRAM references from triggering DRAM prefetch requests.
02AA	DRAM Prefetcher	Turns on the DRAM prefetch unit in the Northbridge.
02AB	HW Prefetch Training on SW	Disables hardware prefetcher from considering software prefetches when detecting strides for prefetch requests.
02AC	HW Prefetch Training on SW	Enables Hardware prefetcher considers software prefetches when detecting strides for prefetch requests. (default)
02AD	SR-IOV Global Enable	Enables BIOS support for SRIOV devices.
02AE	SR-IOV Global Enable	Disables BIOS support for SRIOV devices.
02B6	Memory Operating Voltage	Indicates all DIMMs in the system are operating at 1.5 volts.
02B7	Memory Operating Voltage	Indicates all DIMMs in the system are operating at 1.35 volts.
02B8	Memory Operating Voltage	This setting indicates the memory operating voltage will be set automatically by the Memory initialization code and depends upon the installed DIMM's capability and the memory configuration of the system. This is the default setting and will set the Memory Operating voltage to the POR voltage.
02C5	DCU Streamer Prefetcher	This field enables (Default) the DCU Streamer Prefetcher.
02C6	DCU Streamer Prefetcher	This field disables the DCU Streamer Prefetcher.

Token	Setup option	Description
02C7	Data Reuse Optimization	Sets to enable (Default) for HPC applications.
02C8	Data Reuse Optimization	Sets to disable for energy efficiency.
02C9	QPI Bandwidth Priority	Sets to Compute (Default) for computation-intensive applications.
02CA	QPI Bandwidth Priority	Sets to I/O for I/O-intensive applications.
02CE	DCU IP Prefetcher	This field enables (Default) the DCU IP Prefetcher.
02CF	DCU IP Prefetcher	This field disables the DCU IP Prefetcher.
401A	Terminal Type	The BIOS console redirection, if enabled, operates in VT100 emulation model. See also tokens BFh, C0h, and D7h.
401B	Terminal Type	The BIOS console redirection, if enabled, operates in ANSI emulation model. See also tokens BFh, C0h, and D7h.
401C	Redirection After BIOS POST	The BIOS console redirection, if enabled, continues to operate after the OS boot hand-off.
401D	Redirection After BIOS POST	The BIOS console redirection, if enabled, operates during the BIOS boot only and is disabled prior to OS boot hand-off. See also tokens BFh, C0h, D7h, 401Ah and 401Bh.
4022	1st Boot Device	Whenever the BIOS boots the system, the first PXE-capable device is inserted as the first device in the boot sequence. Enabling this feature causes the BIOS operation to occur on the next and all subsequent boots and causes a change in the system's defined boot sequence. The BIOS chooses the first PXE-capable device as the system's onboard network controller, if present and enabled, or the first bootable network device found in the system's standard PCI search order.

Token	Setup option	Description
4026	Manufacturing Mode	Enable the manufacturing mode to bypass POST tasks/memory tests and F1/F2 prompts on specific error messages. Used by Manufacturing; not for general customer use.
4027	Manufacturing Mode	Disable the manufacturing mode to bypass POST tasks/memory tests and F1/F2 prompts on specific error messages. Used by Manufacturing; not for general customer use.
4033	Serial Port Mode	Console Redirection baud rate will be set to 115,200 bits per second.
4034	Serial Port Mode	Console Redirection baud rate will be set to 57,600 bits per second.
4035	Serial Port Mode	Console Redirection baud rate will be set to 19,200 bits per second.
4036	Serial Port Mode	Console Redirection baud rate will be set to 9,600 bits per second.
403F	Clear SMBIOS System Event Log	The system event log to be cleared on the next boot.
4800	Node Manager	Allows user to enable the Node Manager mode for Intel CPUs.
4801	APML	Allows user to enable the Advanced Platform Management Link mode for AMD CPUs.
4802	Processor Power Capping	To decide the highest performance P-state in OS. (P0-state)
4803	Processor Power Capping	To decide the highest performance P-state in OS. (P1-state)
4804	Processor Power Capping	To decide the highest performance P-state in OS. (P2-state)
4805	Processor Power Capping	To decide the highest performance P-state in OS. (P3-state)
4806	Processor Power Capping	To decide the highest performance P-state in OS. (P4-state)

Token	Setup option	Description
480A	Cr6 State	The C6 is disabled by user in their own liability. There will be warning message in both the BIOS Setup help text and the pop up message when the option is changing.
480B	C6 State	The C6 is enabled by default.
480C	L3 Cache Power Control	The clock to idle subcaches in the L3 is not stopped.
480D	L3 Cache Power Control	The clock to idle subcaches in the L3 is stopped.
480E	C7 State	The C7 is disabled by user in their own liability. There will be warning message in both the BIOS Setup help text and the pop up message when the option is changing.
480F	C7 State	The C7 is enabled by default.
4810	Non Coherent HT Link Width	Set HT Link to 8 bit width.
4811	Non Coherent HT Link Width	Set HT Link 16 to bit width.
4812	Non Coherent HT Link Speed	Set HT Link speed as 800MHz.
4813	Non Coherent HT Link Speed	Set HT Link speed as 1000MHz.
4814	Non Coherent HT Link Speed	Set HT Link speed as 1200MHz.
4815	Non Coherent HT Link Speed	Set HT Link speed as 1600MHz.
4816	Non Coherent HT Link Speed	Set HT Link speed as 2000MHz.
4817	Non Coherent HT Link Speed	Set HT Link speed as 2600MHz.
4820	Memory Turbo Mode	Disables memory turbo mode.
4821	Memory Turbo Mode	Enables memory turbo mode.

Token	Setup option	Description
4823	Memory Frequency	Detects the memory running speed from H/W designed (SPD, memory population).
4824	Memory Frequency	Sets memory running speed ups to 800MHz.
4825	Memory Frequency	Sets memory running speed ups to 1066MHz.
4826	Memory Frequency	Sets memory running speed ups to 1333MHz.
4827	Memory Frequency	Sets memory running speed ups to 1600MHz.
4828	Memory Throttling Mode	Sets memory running as Open Loop Throughput Throttling (OLTT) (Default).
4829	Memory Throttling Mode	Sets memory running as Closed Loop Thermal Throttling (CLTT).
482A	DRAM Scrubbing	Disables Dram scrubbing is the ability to write corrected data back to the memory once a correctable error is detected on a read transaction.
482B	DRAM Scrubbing	Enables Dram scrubbing is the ability to write corrected data back to the memory once a correctable error is detected on a read transaction.
482C	Demand Scrubbing	Disables Demand scrubbing is the ability to write corrected data back to the memory once a correctable error is detected on a read transaction.
482D	Demand Scrubbing	Enables Demand scrubbing is the ability to write corrected data back to the memory once a correctable error is detected on a read transaction.
482E	Patrol Scrubbing	Disables Patrol scrubbing proactively searches the system memory, repairing correctable errors.
482F	Patrol Scrubbing	Enables Patrol scrubbing proactively searches the system memory, repairing correctable errors.
4830	HDD Security Erase	Sets the HDD Security Freeze Lock to all of HDDs.

Token	Setup option	Description
4831	HDD Security Erase	Unlocks the HDD Security Freeze Lock to all of HDDs.
4832	AHCI-AMD	Supports AMD inbox AHCI driver.
4833	AHCI-MS	Supports Microsoft inbox AHCI driver.
4834	Embedded SATA Link Rate	Sets the SATA link rate at maximum.
4835	Embedded SATA Link Rate	Sets the SATA link rate at minimum as 1.5 Gbps. For power consumption.
4836	Embedded SATA Link Rate	Sets the SATA link rate at minimum as 3.0 Gbps.
4840	PCI-E Slot ASPM	Controls the level of ASPM supported on the PCI-E Link of port. All entry disabled.
4841	PCI-E Slot ASPM	Controls the level of ASPM supported on the given PCI-E Link of port. L0s entry enabled.
4842	PCI-E Slot ASPM	Controls the level of ASPM supported on the given PCI-E Link of port. L1 entry enabled.
4843	PCI-E Slot ASPM	Controls the level of ASPM supported on the given PCI-E Link of port. L0s and L1 entry enabled.
4844	PCI-E Slot ASPM	Controls the level of ASPM supported on the given PCI-E Link of port. L0s entry downstream enabled.
4845	PCI-E Slot ASPM	Controls the level of ASPM supported on the given PCI-E Link of port. L0s entry downstream and L1 enabled.
4846	Onboard LAN ASPM	Controls the level of ASPM supported to on-board LAN. All entry disabled.
4847	Onboard LAN ASPM	Controls the level of ASPM supported to on-board LAN. L0s entry enabled.
4848	Onboard LAN ASPM	Controls the level of ASPM supported to on-board LAN. L1 entry enabled.

Token	Setup option	Description
4849	Onboard LAN ASPM	Controls the level of ASPM supported to on-board LAN. L0s and L1 entry enabled.
484A	Onboard LAN ASPM	Controls the level of ASPM supported to on-board LAN. L0s entry downstream enabled.
484B	Onboard LAN ASPM	Controls the level of ASPM supported to on-board LAN. L0s entry downstream and L1 enabled.
484C	Mezzanine Slot ASPM	Controls the level of ASPM supported on Mezzanine Slot. All entry disabled.
484D	Mezzanine Slot ASPM	Controls the level of ASPM supported on Mezzanine Slot. L0s entry enabled.
484E	Mezzanine Slot ASPM	Controls the level of ASPM supported on Mezzanine Slot. L1 entry enabled.
484F	Mezzanine Slot ASPM	Controls the level of ASPM supported on Mezzanine Slot. L0s and L1 entry enabled.
4850	Mezzanine Slot ASPM	Controls the level of ASPM supported on Mezzanine Slot. L0s entry downstream enabled.
4851	Mezzanine Slot ASPM	Controls the level of ASPM supported on Mezzanine Slot. L0s entry downstream and L1 enabled.
4852	NB-SB Link ASPM	Controls the level of ASPM supported on the NB-SB. All entry disabled.
4853	NB-SB Link ASPM	Controls the level of ASPM supported on the NB-SB. L1 entry enabled.
4854	Maximum Payload Size	Auto detects the PCI-E maximum payload size.
4855	Maximum Payload Size	Sets the PCI-E maximum payload size to 128 Bytes.
4856	Maximum Payload Size	Sets the PCI-E maximum payload size to 256 Bytes
4857	WHEA Support	Disables Windows Hardware Error Architecture.

Token	Setup option	Description
4858	WHEA Support	Enables Windows Hardware Error Architecture.
4859	NIC Enumeration	Default, Set PXE boot from on-board NIC then Add-on NIC adapter.
485A	NIC Enumeration	Set PXE boot from Add-on NIC adapter then on-board NIC.
485B	PCI-E Generation	Set the PCI signaling rate at Gen3 8.0 Gigabits bandwidth.
485C	PCI-E Generation	Set the PCI signaling rate at Gen2 5.0 Gigabits bandwidth.
485D	PCI-E Generation	Set the PCI signaling rate at Gen1 2.5 Gigabits bandwidth.
 NOTE: The PCI-E Gen2 x16 slot 1 and slot 2 are supported up to Gen2 5.0 Gigabits bandwidth. If user inserts Gen3 .0 devices into the 2 slots that will only train at Gen 2.0 speed, not Gen 3.0.		
485E	Reboot on WOL (ROW)	Disables the ROW in default, Reboot on WOL(ROW) is a feature which repurposes the traditional Wake on LAN (WOL) signal to reboot the motherboard. During system is in S0/S3
485F	Reboot on WOL (ROW)	Enables the ROW, Reboot on WOL(ROW) is a feature which repurposes the traditional Wake on LAN (WOL) signal to reboot the motherboard. During system is in S0/S3 state, when a WOL packet is received by the NIC, the wake-up signal generated by the NIC shall cause a hardware reboot of the motherboard.
4860	USB PORT with BMC	This feature will allow the users to electrically disable the internal USB port which contacts to BMC.
4861	USB PORT with BMC	This feature will allow the users to electrically enable the internal USB port which contacts to BMC.
4870	Force PXE Boot only	Disables PXE to be the boot device only.
4871	Force PXE Boot only	Enables PXE to be the boot device only. The system retrying to boot from PXE device.

Token	Setup option	Description
4873	Active Processor Cores	This field controls the number of enabled 16 cores in each processor. By default, the maximum number of cores per processor will be enabled.
4877	PCI-E Slot1	This feature will allow the users to electrically disable PCI-E Slot1.
4878	PCI-E Slot1	This feature will allow the users to electrically enable PCI-E Slot1.
4879	PCI-E Slot2	This feature will allow the users to electrically disable PCI-E Slot2.
487A	PCI-E Slot2	This feature will allow the users to electrically enable PCI-E Slot2.
487B	PCI-E Slot3	This feature will allow the users to electrically disable PCI-E Slot3.
487C	PCI-E Slot3	This feature will allow the users to electrically enable PCI-E Slot3.
487F	Mezzanine Slot	This feature will allow the users to electrically disable Mezzanine Slot.
4880	Mezzanine Slot	This feature will allow the users to electrically enable Mezzanine Slot.
4881	1st Boot Device	Sets Hard Disk as first boot device.
4882	1st Boot Device	Sets RAID as first boot device.
4883	1st Boot Device	Sets USB Storage as first boot device.
4884	1st Boot Device	Sets CD/DVD ROM as first boot device.
4885	2nd Boot Device	Sets Network as 2nd boot device.
4886	2nd Boot Device	Sets Hard Disk as 2nd boot device.
4887	2nd Boot Device	Sets RAID as 2nd boot device.
4888	2nd Boot Device	Sets USB Storage as 2nd boot device.
4889	2nd Boot Device	Sets CD/DVD ROM as 2nd boot device.
488A	3rd Boot Device	Sets Network as 3rd boot device.
488B	3rd Boot Device	Sets Hard Disk as 3rd boot device.
488C	3rd Boot Device	Sets RAID as 3rd boot device.
488D	3rd Boot Device	Sets USB Storage as 3rd boot device.
488E	3rd Boot Device	Sets CD/DVD ROM as 3rd boot device.

Token	Setup option	Description
488F	4th Boot Device	Sets Network as 4th boot device.
4890	4th Boot Device	Sets Hard Disk as 4th boot device.
4891	4th Boot Device	Sets RAID as 4th boot device.
4892	4th Boot Device	Sets USB Storage as 4th boot device.
4893	4th Boot Device	Sets CD/DVD ROM as 4th boot device.
4894	5th Boot Device	Sets Network as 5th boot device.
4895	5th Boot Device	Sets Hard Disk as 5th boot device.
4896	5th Boot Device	Sets RAID as 5th boot device.
4897	5th Boot Device	Sets USB Storage as 5th boot device.
4898	5th Boot Device	Sets CD/DVD ROM as 5th boot device.
48A0	ACPI SPMI Table	Disables the ACPI SPMI Table for BMC ROM update.
48A1	ACPI SPMI Table	Enables the ACPI SPMI Table for IPMI driver installation.
48A2	BMC LAN Port Configuration	Sets BMC LAN Port to Dedicated-NIC.
48A3	BMC LAN Port Configuration	Sets BMC LAN Port to Shared-NIC.
48A4	BMC NIC IP Source	Sets BMC LAN to get LAN IP from Static mode.
48A5	BMC NIC IP Source	Sets BMC LAN to get LAN IP from DHCP mode.
48A6	IPv6 Mode	Disables IPv6 internet protocol support.
48A7	IPv6 Mode	Enables IPv6 internet protocol support.
48A8	IPv6 AutoConfig	Disables IPv6 auto configuration.
48A9	IPv6 AutoConfig	Enables IPv6 auto configuration.
48AA	Serial Port Mode	Console Redirection baud rate will be set to 3,8400 bits per second.
48AB	Flow Control	Remote access flow controls by none.
48AC	Flow Control	Remote access flow controls by hardware.

Token	Setup option	Description
48AD	Flow Control	Remote access flow controls by software.
48AE	Terminal Type	The BIOS console redirection, if enabled, operates in VTUTF8 emulation model. See also tokens BFh, C0h, and D7h.
48AF	VT-UTF8 Combo Key Support	Disables VT-UTF8 Combination Key Support for ANSI/VT100 terminals.
48B0	VT-UTF8 Combo Key Support	Enables VT-UTF8 Combination Key Support for ANSI/VT100 terminals.
48B1	Event logging	Disables BIOS to log system events to BMC, errors include ECC/PCI/PCI-E/HT...etc.
48B2	Event logging	Enables BIOS to log system events to BMC, errors include ECC/PCI/PCI-E/HT...etc.
48B3	NMI on Error	Disables BIOS to generate NMI when PCI-E uncorrectable errors occur.
48B4	NMI on Error	Enables BIOS to generate NMI when PCI-E uncorrectable errors occur.
48B5	Memory Operating Voltage	Indicates all DIMMs in the system are operating at 1.25 volts.
48C0	Frequency Ratio	Sets frequency multiplier as maximum level.
48C1	Frequency Ratio	Downgrades frequency multiplier one level.
48C2	Frequency Ratio	Downgrades frequency multiplier two levels.
48C3	Frequency Ratio	Downgrades frequency multiplier three levels.
48C8	QPI Frequency	Sets the QPI frequency runs at maximum speed.
48C9	QPI Frequency	Sets the QPI frequency runs at 4.800GT.
48CA	QPI Frequency	Sets the QPI frequency runs at 5.866GT.
48CB	QPI Frequency	Sets the QPI frequency runs at 6.400GT.
48CC	QPI Frequency	Sets the QPI frequency runs at 7.200GT.

Token	Setup option	Description
48CD	QPI Frequency	Sets the QPI frequency runs at 8.000GT.
48D0	Energy Efficient Policy	Controls the energy efficient policy as performance profile to configure all necessary settings.
48D1	Energy Efficient Policy	Default, controls the energy efficient policy as balance profile to configure all necessary settings.
48D2	Energy Efficient Policy	Controls the energy efficient policy as low power profile to configure all necessary settings.
48D3	Direct Cache Access	Disables the Direct Cache Access.
48D4	Direct Cache Access	Enables the Direct Cache Access.
48D8	Load Customized Defaults	Requests a customized default of SETUP values on the next boot.
48DA	Save Customized Defaults	Saves current settings to customized defaults of SETUP on next boot.
48DB	N/A	Requests maximum performance settings of SETUP values on the next boot.
48DC	N/A	Requests a energy efficiency settings of SETUP values on the next boot.
48DD	N/A	Requests HPC efficiency settings of SETUP values on the next boot. Dell will provide the settings before A-can BIOS.
48DE	EFI Shell	Requests the EFI Shell as first boot device on the next boot.
48DF	Dell ePSA Diagnostic Tool	Requests auto launches ePSA diagnostic tool on the next boot.
48E0	N/A	The NIC3 is used for 1st device of PXE boot on the next boot, followed by NIC1.
48E1	N/A	The NIC4 is used for 1st device of PXE boot on the next boot, followed by NIC1.

Token	Setup option	Description
48E2	N/A	The NIC5 is used for 1st device of PXE boot on the next boot, followed by NIC1.
48E3	N/A	The NIC6 is used for 1st device of PXE boot on the next boot, followed by NIC1.
48E4	N/A	The NIC7 is used for 1st device of PXE boot on the next boot, followed by NIC1.
48E5	N/A	The NIC8 is used for 1st device of PXE boot on the next boot, followed by NIC1.
48E6	N/A	The HDD1 is used for 1st device of PXE boot on the next boot.
48E7	N/A	The HDD2 is used for 1st device of PXE boot on the next boot.
48E8	N/A	The HDD3 is used for 1st device of PXE boot on the next boot.
48E9	N/A	The HDD4 is used for 1st device of PXE boot on the next boot.
48EA	N/A	The HDD5 is used for 1st device of PXE boot on the next boot.
48EB	N/A	The HDD6 is used for 1st device of PXE boot on the next boot.
48EC	N/A	The RAID HDD1 is used for 1st device of PXE boot on the next boot.
48ED	N/A	The RAID HDD2 is used for 1st device of PXE boot on the next boot.
48EE	N/A	The RAID HDD3 is used for 1st device of PXE boot on the next boot.
48EF	N/A	The RAID HDD4 is used for 1st device of PXE boot on the next boot.
48F0	N/A	The RAID HDD5 is used for 1st device of PXE boot on the next boot.
48F1	N/A	The RAID HDD6 is used for 1st device of PXE boot on the next boot.

Token	Setup option	Description
48F2	N/A	The RAID HDD7 is used for 1st device of PXE boot on the next boot.
48F3	N/A	The RAID HDD8 is used for 1st device of PXE boot on the next boot.
48F4	N/A	The RAID HDD9 is used for 1st device of PXE boot on the next boot.
48F5	N/A	The RAID HDD10 is used for 1st device of PXE boot on the next boot.
48F6	N/A	The RAID HDD11 is used for 1st device of PXE boot on the next boot.
48F7	N/A	The RAID HDD12 is used for 1st device of PXE boot on the next boot.
48F8	N/A	The RAID HDD13 is used for 1st device of PXE boot on the next boot.
48F9	N/A	The RAID HDD14 is used for 1st device of PXE boot on the next boot.
48FA	N/A	The RAID HDD15 is used for 1st device of PXE boot on the next boot.
48FB	N/A	The RAID HDD16 is used for 1st device of PXE boot on the next boot.
48FC	N/A	The HDD7 is used for 1st device of HDD boot on the next boot.
48FD	N/A	The HDD8 is used for 1st device of HDD boot on the next boot.
4900	PCI-E Slot1	This feature allows user to enable PCI-E Slot1 without option ROM initialization.
4901	PCI-E Slot2	This feature allows user to enable PCI-E Slot2 without option ROM initialization
4902	PCI-E Slot3	This feature allows user to enable PCI-E Slot3 without option ROM initialization

Token	Setup option	Description
4903	PCI-E Slot4	This feature allows user to enable PCI-E Slot4 without option ROM initialization
4904	Mezzanine Slot	This feature allows user to enable Mezzanine Slot without option ROM initialization.
4910	Chassis Level Capping	This option allow user to disable chassis level capping function.
4911	Chassis Level Capping	Default, this option allow user to enable chassis level capping function.
4912	Sled Level Policy	Default, set sled level policy to refer chassis level policy when Emergency Throttling event trigger.
4913	Sled Level Policy	Set sled level policy as throttling when Emergency Throttling event trigger.
4914	Sled Level Policy	Set sled level policy as throttling when Emergency Throttling event trigger.
4915	Sled Level Policy	Set sled level policy as throttling when Emergency Throttling event trigger.
4916	Chassis Level Policy	Default, set chassis level policy as throttling when Emergency Throttling event trigger.
4917	Chassis Level Policy	Set chassis level policy as power off when Emergency Throttling event trigger.
4918	N/A	Default, disables clock spread spectrum.
4919	N/A	Enables clock spread spectrum.
491A	PCI 64 BIT DECODE	Disable pci 64 bit decode
491B	PCI 64 BIT DECODE	Enable pci 64 bit decode
491C	PCI 64 BIT DECODE	Auto config pci 64 bit decode

Token	Setup option	Description
4875	Perfmon and DFX Devices	Disable Perfmon and DFX Devices
4876	Perfmon and DFX Devices	Enable Perfmon and DFX Devices

Table 2-2. The IPMI Command Table

Name	NetFn	Code	IPMI2.0	BMC
IPMI Device Global Commands				
Get Device ID	App (0x06)	0x01	M	Y
Broadcast Get Device ID	App (0x06)	0x02	M	Y
Cold Reset	App (0x06)	0x03	O	Y
Warm Reset	App (0x06)	0x04	O	
Get Self Test Results	App (0x06)	0x05	M	Y
Manufacturing Test On	App (0x06)	0x06	O	Y
Get ACPI Power State	App (0x06)	0x07	O	Y
Get Device GUID	App (0x06)	0x08	O	Y
Get NetFn Support	App (0x06)	0x09	O	Y
Get Command Support	App (0x06)	0x0A	O	Y
Get Command Sub-function Support	App (0x06)	0x0B	O	Y
Get Configurable Commands	App (0x06)	0x0C	O	Y
Get Configurable Command Sub-functions	App (0x06)	0x0D	O	Y
Set Command Enables	App (0x06)	0x60	O	Y
Get Command Enables	App (0x06)	0x61	O	Y
Set Command Sub-function Enables	App (0x06)	0x62	O	Y
Get Command Sub-function Enables	App (0x06)	0x63	O	Y
Get OEM NetFn IANA Support	App (0x06)	0x64	O	Y
BMC Watchdog Timer Commands				
Reset Watchdog Timer	App (0x06)	0x22	M	Y
Set Watchdog Timer	App (0x06)	0x24	M	Y
Get Watchdog Timer	App (0x06)	0x25	M	Y
BMC Device and Messaging Commands				
Set BMC Global Enables	App (0x06)	0x2E	M	Y
Get BMC Global Enables	App (0x06)	0x2F	M	Y
Clear Message Flags	App (0x06)	0x30	M	Y
Get Message Flags	App (0x06)	0x31	M	Y
Enable Message Channel Receive	App (0x06)	0x32	O	Y
Get Message	App (0x06)	0x33	M	Y

Send Message	App (0x06)	0x34	M	Y
Read Event Message Buffer	App (0x06)	0x35	O	Y
Get BT Interface Capabilities	App (0x06)	0x36	M	
Get System GUID	App (0x06)	0x37	O	Y
Set System Info Parameters	App (0x06)	0x58	O	Y
Get System Info Parameters	App (0x06)	0x59	O	Y
Get Channel Authentication Capabilities	App (0x06)	0x38	O	Y
Get Session Challenge	App (0x06)	0x39	O	Y
Active Session	App (0x06)	0x3A	O	Y
Set Session Privilege Level	App (0x06)	0x3B	O	Y
Close Session	App (0x06)	0x3C	O	Y
Get Session Info	App (0x06)	0x3D	O	Y
Get AuthCode	App (0x06)	0x3F	O	Y
Set Channel Access	App (0x06)	0x40	O	Y
Get Channel Access	App (0x06)	0x41	O	Y
Get Channel Info	App (0x06)	0x42	O	Y
Set User Access	App (0x06)	0x43	O	Y
Get User Access	App (0x06)	0x44	O	Y
Set User Name	App (0x06)	0x45	O	Y
Get User Name	App (0x06)	0x46	O	Y
Set User Password	App (0x06)	0x47	O	Y
Activate Payload	App (0x06)	0x48	O	Y
Deactivate Payload	App (0x06)	0x49	O	Y
Get Payload Activation Status	App (0x06)	0x4A	O	Y
Get Payload Instance Info	App (0x06)	0x4B	O	Y
Set User Payload Access	App (0x06)	0x4C	O	Y
Get User Payload Access	App (0x06)	0x4D	O	Y
Get Channel Payload Support	App (0x06)	0x4E	O	Y
Get Channel Payload Version	App (0x06)	0x4F	O	Y
Get Channel OEM Payload Info	App (0x06)	0x50	O	Y
Master Write-Read	App (0x06)	0x52	O	Y
Get Channel Cipher Suites	App (0x06)	0x54	O	Y
Suspend/Resume Payload Encryption	App (0x06)	0x55	O	Y

Set Channel Security Keys	App (0x06)	0x56	O	Y
Get System Interface Capabilities	App (0x06)	0x57	O	
Chassis Device Commands				
Get Chassis Capabilities	Chassis (0x00)	0x00	M	Y
Get Chassis Status	Chassis (0x00)	0x01	M	Y
Chassis Control	Chassis (0x00)	0x02	O	
Chassis Reset	Chassis (0x00)	0x03	O	
Chassis Identify	Chassis (0x00)	0x04	O	
Set Front Panel Button	Chassis (0x00)	0x0A	O	
Set Chassis Capabilities	Chassis (0x00)	0x05	O	Y
Set Power Restore Policy	Chassis (0x00)	0x06	O	
Set Power Cycle Interval	Chassis (0x00)	0x0B	O	
Get System Restart Cause	Chassis (0x00)	0x07	O	
Set System Boot Options	Chassis (0x00)	0x08	O	
Get System Boot Options	Chassis (0x00)	0x09	O	
Get POH Counter	Chassis (0x00)	0x0F	O	
Event Commands				
Set Event Receiver	S/E (0x04)	0x00	M	Y
Get Event Receiver	S/E (0x04)	0x01	M	Y
Platform Event (or Event Message)	S/E (0x04)	0x02	M	Y
PEF and Alerting Commands				
Get PEF Capabilities	S/E (0x04)	0x10	M	Y
Arm PEF Postpone Timer	S/E (0x04)	0x11	M	Y
Set PEF Configuration Parameters	S/E (0x04)	0x12	M	Y
Get PEF Configuration Parameters	S/E (0x04)	0x13	M	Y
Set Last Processed Event ID	S/E (0x04)	0x14	M	Y
Get Last Processed Event ID	S/E (0x04)	0x15	M	Y
Alert Immediate	S/E (0x04)	0x16	O	Y
PET Acknowledge	S/E (0x04)	0x17	O	Y
Sensor Device Commands				
Get Device SDR Info	S/E (0x04)	0x20	O	
Get Device SDR	S/E (0x04)	0x21	O	
Reserve Device SDR Repository	S/E (0x04)	0x22	O	

Get Sensor Reading Factors	S/E (0x04)	0x23	O	Y
Set Sensor Hysteresis	S/E (0x04)	0x24	O	Y
Get Sensor Hysteresis	S/E (0x04)	0x25	O	Y
Set Sensor Threshold	S/E (0x04)	0x26	O	Y
Get Sensor Threshold	S/E (0x04)	0x27	O	Y
Set Sensor Event Enable	S/E (0x04)	0x28	O	Y
Get Sensor Event Enable	S/E (0x04)	0x29	O	Y
Re-arm Sensor Events	S/E (0x04)	0x2A	O	Y
Get Sensor Event Status	S/E (0x04)	0x2B	O	Y
Get Sensor Reading	S/E (0x04)	0x2D	M	Y
Set Sensor Type	S/E (0x04)	0x2E	O	
Get Sensor Type	S/E (0x04)	0x2F	O	
Set Sensor Reading And Event Status	S/E (0x04)	0x30	O	Y
FRU Device Commands				
Get FRU Inventory Area Info	Storage (0x0A)	0x10	M	Y
Read FRU Data	Storage (0x0A)	0x11	M	Y
Write FRU Data	Storage (0x0A)	0x12	M	Y
SDR Device Commands				
Get SDR Repository Info	Storage (0x0A)	0x20	M	Y
Get SDR Repository Allocation Info	Storage (0x0A)	0x21	O	
Reserve SDR Repository	Storage (0x0A)	0x22	M	Y
Get SDR	Storage (0x0A)	0x23	M	Y
Add SDR	Storage (0x0A)	0x24	M	
Partial Add SDR	Storage (0x0A)	0x25	M	Y
Delete SDR	Storage (0x0A)	0x26	O	
Clear SDR Repository	Storage (0x0A)	0x27	M	Y
Get SDR Repository Time	Storage (0x0A)	0x28	O/M	Y
Set SDR Repository Time	Storage (0x0A)	0x29	O/M	Y
Enter SDR Repository Update Mode	Storage (0x0A)	0x2A	O	
Exit SDR Repository Update Run	Storage (0x0A)	0x2B	O	
Run Initialization Agent	Storage (0x0A)	0x2C	O	Y
SEL Device Commands				
Get SEL Info	Storage (0x40)	0x40	M	Y

Get SEL Allocation Info	Storage (0x40)	0x41	O	
Reserve SEL	Storage (0x40)	0x42	O	Y
Get SEL Entry	Storage (0x40)	0x43	M	Y
Add SEL Entry	Storage (0x40)	0x44	M	Y
Partial Add SEL Entry	Storage (0x40)	0x45	M	
Delete SEL Entry	Storage (0x40)	0x46	O	
Clear SEL	Storage (0x40)	0x47	M	Y
Get SEL Time	Storage (0x40)	0x48	M	Y
Set SEL Time	Storage (0x40)	0x49	M	Y
Get Auxiliary Log Status	Storage (0x40)	0x5A	O	
Set Auxiliary Log Status	Storage (0x40)	0x5B	O	
Get SEL Time UTC Offset	Storage (0x40)	0x5C	O	
Set SEL Time UTC Offset	Storage (0x40)	0x5D	O	
LAN Device Commands				
Set LAN Configuration Parameters	Transport (0x0C)	0x01	M	Y
Get LAN Configuration Parameters	Transport (0x0C)	0x02	M	Y
Suspend BMC ARPs	Transport (0x0C)	0x03	O	
Get IP/UDP/RMCP Statistics	Transport (0x0C)	0x04	O	
Serial/Modem Device Commands				
Set Serial/Modem Configuration	Transport (0x0C)	0x10	M	Y
Get Serial/Modem Configuration	Transport (0x0C)	0x11	M	Y
Set Serial/Modem Mux	Transport (0x0C)	0x12	O	Y
Get TAP Response Codes	Transport (0x0C)	0x13	O	
Set PPP UDP Proxy Transmit Data	Transport (0x0C)	0x14	O	
Get PPP UDP Proxy Transmit Data	Transport (0x0C)	0x15	O	
Send PPP UDP Proxy Packet	Transport (0x0C)	0x16	O	
Get PPP UDP Proxy Receive Data	Transport (0x0C)	0x17	O	
Serial/Modem Connection Active	Transport (0x0C)	0x18	M	Y
Callback	Transport (0x0C)	0x19	O	
Set User Callback Options	Transport (0x0C)	0x1A	O	
Get User Callback Options	Transport (0x0C)	0x1B	O	
Set Serial Routing Mux	Transport (0x0C)	0x1C	O	Y
SOL Activating	Transport (0x0C)	0x20	O	Y
Set SOL Configuration Parameters	Transport (0x0C)	0x21	O	Y

Get SOL Configuration Parameters	Transport (0x0C)	0x22	O	Y
Command Forwarding Commands				
Forwarded Command	Transport (0x0C)	0x30	O	Y
Set Forwarded Commands	Transport (0x0C)	0x31	O	Y
Get Forwarded Commands	Transport (0x0C)	0x32	O	Y
Enable Forwarded Commands	Transport (0x0C)	0x33	O	Y
Firmware Update Commands				
Firmware Update Phase 1	Firmware (0x08)	0x10	O	Y
Firmware Update Phase 2	Firmware (0x08)	0x11	O	Y
Firmware Update Phase 3	Firmware (0x08)	0x21	O	Y
Get Firmware Update Status	Firmware (0x08)	0x12	O	Y
Get Firmware Version	Firmware (0x08)	0x13	O	Y
Set Firmware Update Status	Firmware (0x08)	0x16	O	Y

Table 2-3. The Power Management Settings

Setup Menu Setting		Maximum Performance (48DB)		Energy Efficiency (48DC)	
Setup Page	Setting	Option	D4 Token	Option	D4 Token
Power Management	Power Management	Max. Performance	021F	Node Manager	4800
	Energy Efficiency Policy	Performance	48D0	Low Power	48D2
Processor Configuration	Active Processor Cores	All	026E	1/2	0233 /0232
	Frequency Ratio	Auto	48C0	3	48C3
	QPI Frequency	Auto	48C8	4.80GT/s	48C9
	Turbo Mode	Enabled	01E8	Disabled	01EA
	C State	Disabled	024C	Enabled	024B
	C1E State	Disabled	02A2	Enabled	02A1
	C6 State	Disabled	480A	Enabled	480B
	C7 State	Disabled	480E	Enabled	480F
	Direct Cache Access	Enabled	48D4	Disabled	48D3
	Hyper-Threading Technology	Enabled	00D1	Disabled	00D2
	Adjacent Cache Line Prefetch	Enabled	0172	Disabled	0171

	Hardware Prefetcher	Enabled	0174	Disabled	0173
	DCU Streamer Prefetcher	Enabled	02C5	Disabled	02C6
	DCU IP Prefetcher	Enabled	02CE	Disabled	02CF
Memory Configuration	Memory Frequency	Auto	4823	800 MHz	4824
	Memory Turbo Mode	Enabled	4821	Disabled	4820
	Memory Throttling Mode	Disabled	4828	Enabled	4829
	Memory Operating Voltage	1.5 V	02B6	1.35V /1.25V	02B7 /48B5
SATA Configuration	Embedded SATA Link State	Auto	4834	1.5 Gbps	4835
	Power Saving Features	Disabled	0199	Enabled	019A
PCI Configuration	PCI-E Slot ASPM	Disabled	4840	L0s & L1	4843
	Onboard LAN ASPM	Disabled	4846	L0s & L1	4849
	Mezzing Slot ASPM	Disabled	484C	L0s & L1	484F
	NB-SB Link ASPM	Disabled	4852	L1	4853
	PCI-E Generation	Gen3/Gen2	485B/485C	Gen1	485D



NOTE: The PCI-E Gen2 x16 slot 1 and slot 2 are supported up to Gen2 5.0 Gigabits bandwidth. If user inserts Gen3.0 devices into the 2 slots that will only train at Gen 2.0 speed, not Gen 3.0.

Installing System Components

Safety Instructions



WARNING: Working on systems that are still connected to a power supply can be extremely dangerous.



CAUTION: System components and electronic circuit boards can be damaged by discharge of static electricity.



CAUTION: Many repairs may only be done by a certified service technician. You should only perform troubleshooting and simple repairs as authorized in your product documentation, or as directed by the online or telephone service and support team. Damage due to servicing that is not authorized by Dell is not covered by your warranty. Read and follow the safety instructions that came with the product.

To avoid injury to yourself or damage to system, follow these guidelines:

- Always disconnect the system from the power outlet whenever you are working inside the system.
- If possible, wear a grounded wrist strap as you work inside the system. Or discharge any static electricity by touching the bare metal chassis of system case, or the bare metal body of any other grounded appliance.
- Hold electronic circuit boards by the edges only. Do not touch the components on the board unless it is necessary to do so. Do not flex or stress the circuit board.
- Leave all components inside the static-proof packaging until you are ready to use the component for the installation.

Recommended Tools

- #1 Phillips screwdriver
- #2 Phillips screwdriver

Tox #T20 screwdriverInside the System



CAUTION: Many repairs may only be done by a certified service technician. You should only perform troubleshooting and simple repairs as authorized in your product documentation, or as directed by the online or telephone service and support team. Damage due to servicing that is not authorized by Dell is not covered by your warranty. Read and follow the safety instructions that came with the product.



CAUTION: This system must be operated with the system cover installed to ensure proper cooling.



NOTE: The illustration in this section shows a system with 12 x3.5-inch hard drives as an example.

Figure 3-1. Inside the System with 1U Node

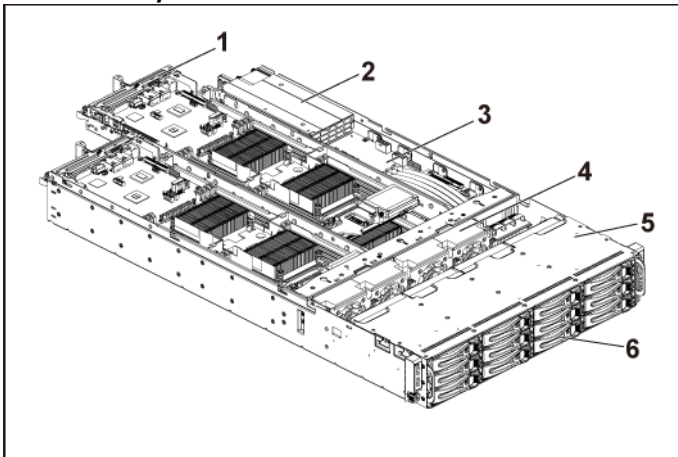

- | | | | |
|---|------------------------------|---|------------------|
| 1 | system board assembly (4) | 2 | power supply (2) |
| 3 | power distribution board (2) | 4 | cooling fan (4) |
| 5 | hard-drive bay | 6 | hard drive (12) |

Figure 3-2. Inside the System with 2U Node

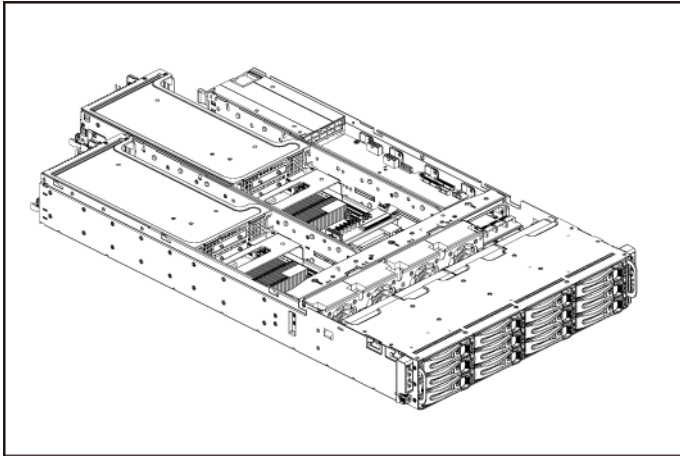

- | | | | |
|---|------------------------------|---|------------------|
| 1 | system board assembly (2) | 2 | power supply (2) |
| 3 | power distribution board (2) | 4 | cooling fan (4) |
| 5 | hard-drive bay | 6 | hard drive (12) |

Hard Drives

Removing a 3.5-inch Hard-Drive Blank



CAUTION: To maintain proper system cooling, all empty hard-drive bays must have drive blanks installed.



NOTE: This section is applicable to systems with hot-swappable hard drives only.

- 1 Pull the hard-drive blank out of the hard-drive bay. See Figure 3-3.

Figure 3-3. Removing or Installing a 3.5-inch Hard-Drive Blank

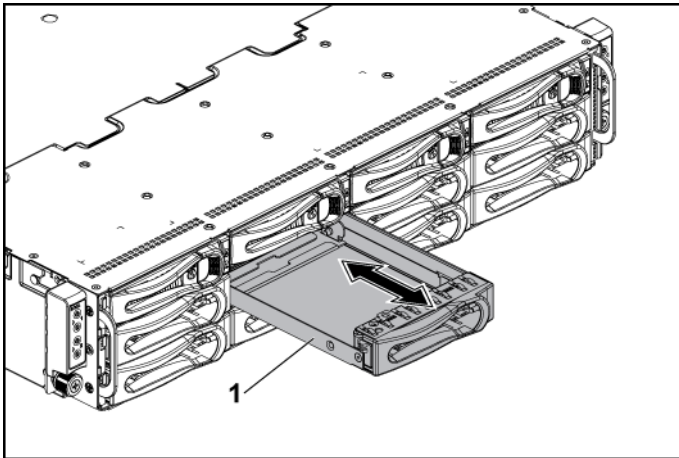

- 1 3.5-inch hard-drive blank

Installing a 3.5-inch Hard-Drive Blank

- 1 Slide the hard-drive blank into the drive bay until the hard-drive blank is seated in place. See Figure 3-3.

Removing a 2.5-inch Hard-Drive Blank



CAUTION: To maintain proper system cooling, all empty hard-drive bays must have drive blanks installed.



NOTE: This section is applicable to systems with hot-swappable hard drives only.

- 1 Pull the handle to remove the 2.5-inch hard-drive blank out of the hard-drive bay. See Figure 3-4.

Figure 3-4. Removing or Installing a 2.5-inch Hard-Drive Blank

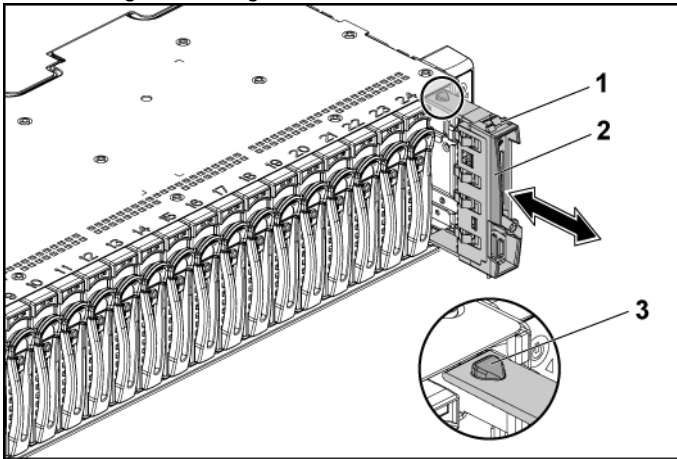

- | | | | |
|---|---------------------------|---|--------|
| 1 | 2.5-inch hard-drive blank | 2 | handle |
| 3 | latch | | |

Installing a 2.5-inch Hard-Drive Blank

- 1 With the latch side facing up, slide the latch into the hard-drive bay first.
- 2 Push the 2.5-inch hard-drive with a slight inclination into the hard-drive bay until the hard-drive blank is seated in place. See Figure 3-4.

Removing a Hard-Drive Carrier

The installation and removal procedures for the 3.5-inch hard drive and the 2.5-inch hard drive are similar. Following is an example showing the replacement procedure of a 3.5-inch hard drive.

△ **CAUTION:** Many repairs may only be done by a certified service technician. You should only perform troubleshooting and simple repairs as authorized in your product documentation, or as directed by the online or telephone service and support team. Damage due to servicing that is not authorized by Dell is not covered by your warranty. Read and follow the safety instructions that came with the product.

△ **CAUTION:** To maintain proper system cooling, all empty hard-drive bays must have drive blanks installed.

- 1 Turn the lock lever counterclockwise until it points to the unlock symbol.
- 2 Slide the release button to open the release handle. See Figure 3-5.
- 3 Using the release handle, pull the hard-drive carrier out of the hard-drive bay.

Figure 3-5. Removing and Installing a Hard-Drive Carrier

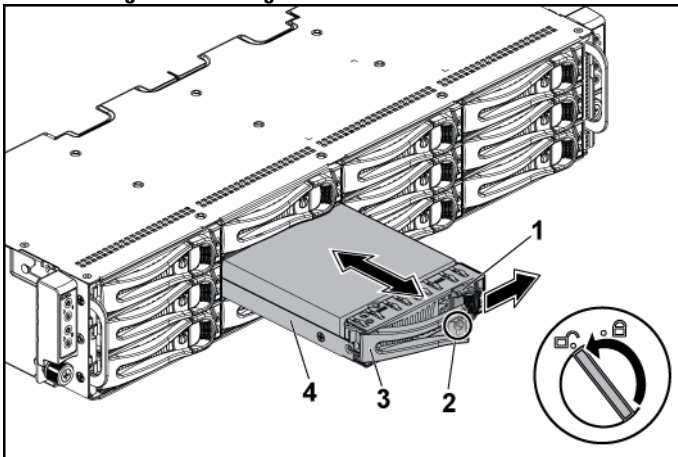

- | | | | |
|---|----------------|---|--------------------|
| 1 | release button | 2 | lock lever |
| 3 | release handle | 4 | hard-drive carrier |

Installing a Hard-Drive Carrier

 **CAUTION:** Many repairs may only be done by a certified service technician. You should only perform troubleshooting and simple repairs as authorized in your product documentation, or as directed by the online or telephone service and support team. Damage due to servicing that is not authorized by Dell is not covered by your warranty. Read and follow the safety instructions that came with the product.

 **CAUTION:** To maintain proper system cooling, all empty hard-drive bays must have drive blanks installed.

- 1 With the lever on the hard-drive carrier open, slide the hard-drive carrier into the drive bay until the hard-drive connector engages with the backplane. See Figure 3-5.
- 2 Close the release handle to lock the hard drive in place.
- 3 Turn the lock lever clockwise to the lock symbol. See Figure 3-5.

Removing a Hard Drive from a Hard-Drive Carrier

 **CAUTION:** Many repairs may only be done by a certified service technician. You should only perform troubleshooting and simple repairs as authorized in your product documentation, or as directed by the online or telephone service and support team. Damage due to servicing that is not authorized by Dell is not covered by your warranty. Read and follow the safety instructions that came with the product.

 **CAUTION:** Ability to mix SAS, SATA and SSD.

- Only 2 drive types can be mixed per node.
- Drives 0 and 1 must be of same type.
- The remaining drives must all be the same type.
- SAS hard drive support will be based on the add-on card and the onboard configuration supports SATA hard drive only.

 **CAUTION:** Use only hard drives that have been tested and approved for use with the SAS/SATA backplane.

△ **CAUTION:** When installing a hard-drive carrier, ensure that the adjacent drives are fully installed. Inserting a hard-drive carrier and attempting to lock its handle next to a partially installed carrier can damage the partially installed carrier's shield spring and make it unusable.

△ **CAUTION:** To prevent data loss, ensure that your operating system supports hot-swappable drive installation. See the documentation supplied with the operating system.

- 1 Remove the four screws. See Figure 3-6.
- 2 Lift the hard drive out of the hard-drive carrier.

Figure 3-6. Removing and Installing a Hard Drive from the Hard-Drive Carrier

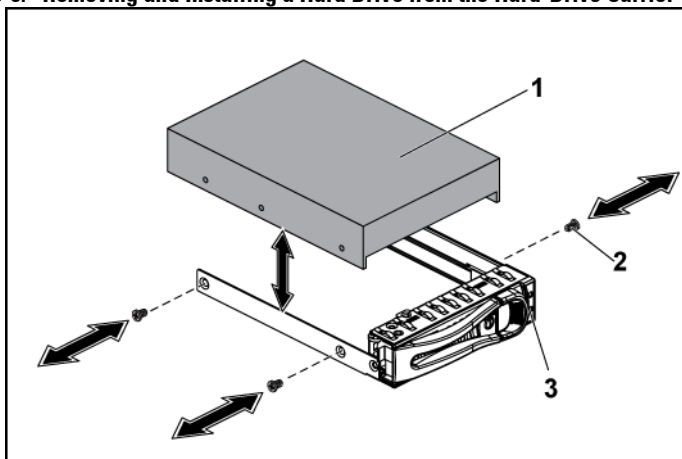

1 hard drive

2 screw (4)

3 hard-drive carrier

Installing a Hard Drive into a Hard-Drive Carrier



CAUTION: Many repairs may only be done by a certified service technician. You should only perform troubleshooting and simple repairs as authorized in your product documentation, or as directed by the online or telephone service and support team. Damage due to servicing that is not authorized by Dell is not covered by your warranty. Read and follow the safety instructions that came with the product.

- 1 Place the hard drive into the hard-drive carrier. See Figure 3-6.
- 2 Secure the hard drive to the hard-drive carrier with four screws. See Figure 3-6.

Power Supplies



NOTE: The following table lists the maximum supported configuration where power supply redundancy is guaranteed.



NOTE: Configurations higher than indicated in the table may change the power supply mode to non-redundant. In non-redundant mode if the power requirement exceeds the installed system power capacity, the BIOS will throttle the processors. Also, if Processor Power Capping is enabled, then processor throttling occurs on configurations that exceed the cap value.



NOTE: Both of these two PSUs are swappable, and they can support hot swap in any condition if system has power throttling feature.

Table 3-1. PSU and System Board Support Matrix

PSU	Two System Boards	Four System Boards
1400 W	Up to two 130W processors / MB three hard drives / MB eight memory modules / MB	Up to one 130 W processor / MB, two hard drives / MB two memory modules / MB
1200 W	Up to two 130W processors / MB three hard drives / MB four memory modules / MB	Up to one 95W processors / MB one hard drive / MB three memory modules / MB

Removing a Power Supply

△ CAUTION: Many repairs may only be done by a certified service technician. You should only perform troubleshooting and simple repairs as authorized in your product documentation, or as directed by the online or telephone service and support team. Damage due to servicing that is not authorized by Dell is not covered by your warranty. Read and follow the safety instructions that came with the product.

△ CAUTION: The System requires at least one power supply to operate normally.

- 1 It is recommended to turn off the system, including any attached peripherals, and disconnect the system from the electrical outlet.
- 2 Disconnect the power cable from the power source and the power supply.
- 3 Press the release lever and using the handle, slide the power supply out of the system. See Figure 3-7.



NOTE: Removing the power supply may require considerable force.

Figure 3-7. Removing and Installing a Power Supply

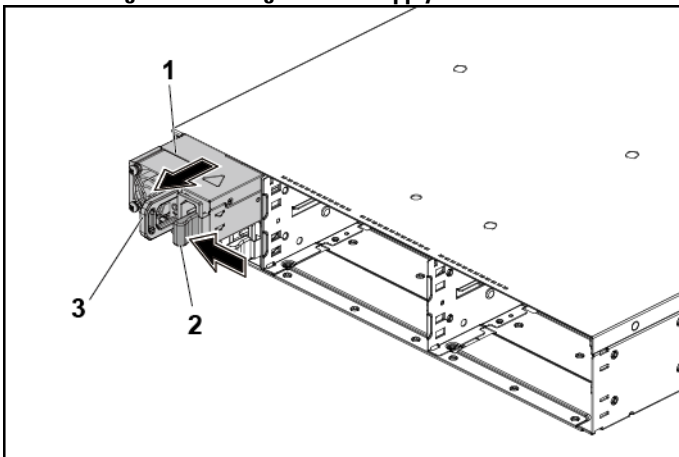

1 power supply

2 release lever

3 handle

Installing a Power Supply



CAUTION: Many repairs may only be done by a certified service technician. You should only perform troubleshooting and simple repairs as authorized in your product documentation, or as directed by the online or telephone service and support team. Damage due to servicing that is not authorized by Dell is not covered by your warranty. Read and follow the safety instructions that came with the product.



CAUTION: The System requires at least one power supply to operate normally.

- 1 Verify that both power supplies are of the same type and have the same maximum output power.



NOTE: The maximum output power is printed on the power supply label.

- 2 Slide the new power supply into the chassis until the power supply is fully seated and the release lever snaps into place. See Figure 3-7.
- 3 Connect the power cable to the power supply and plug the cable into a power outlet.



NOTE: When installing a new power supply in a system with two power supplies, allow several seconds for the system to recognize the power supply and determine its status.

System-Board Assembly

Removing a System-Board Blank Tray



CAUTION: Many repairs may only be done by a certified service technician. You should only perform troubleshooting and simple repairs as authorized in your product documentation, or as directed by the online or telephone service and support team. Damage due to servicing that is not authorized by Dell is not covered by your warranty. Read and follow the safety instructions that came with the product.

- 1 Remove the screw that secures the retaining latch. See Figure 3-8.
- 2 Press the retaining latch and slide the system-board blank tray out of the chassis. See Figure 3-8.

Figure 3-8. Removing and Installing a System-Board Blank Tray

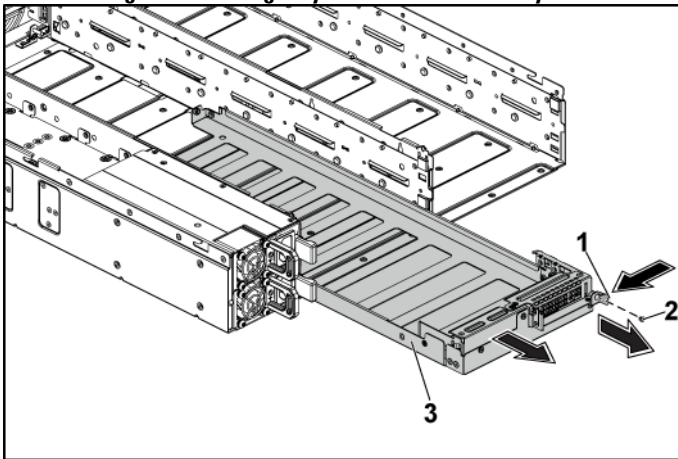

- | | | | |
|---|-------------------------|---|-------|
| 1 | retaining latch | 2 | screw |
| 3 | system-board blank tray | | |

Installing a System-Board Blank Tray



CAUTION: Many repairs may only be done by a certified service technician. You should only perform troubleshooting and simple repairs as authorized in your product documentation, or as directed by the online or telephone service and support team. Damage due to servicing that is not authorized by Dell is not covered by your warranty. Read and follow the safety instructions that came with the product.

- 1 Slide the system-board blank tray into the chassis until it snaps into place. See Figure 3-8.
- 2 Replace the screw that secures the retaining latch. See Figure 3-8.

Removing a System-Board Assembly



CAUTION: Many repairs may only be done by a certified service technician. You should only perform troubleshooting and simple repairs as authorized in your product documentation, or as directed by the online or telephone service and support team. Damage due to servicing that is not authorized by Dell is not covered by your warranty. Read and follow the safety instructions that came with the product.



NOTE: The illustration in this section shows a system with 1U node as an example.

- 1 It is recommended to turn off the system board by pressing the power button on the back panel, and any attached peripherals.
- 2 Disconnect all the external cables from the system board.
- 3 Remove the screw that secures the retaining latch. See Figure 3-9.
- 4 Press the retaining latch and using the handle, slide the system-board assembly out of the chassis. See Figure 3-9.

Figure 3-9. Removing and Installing a System-Board Assembly

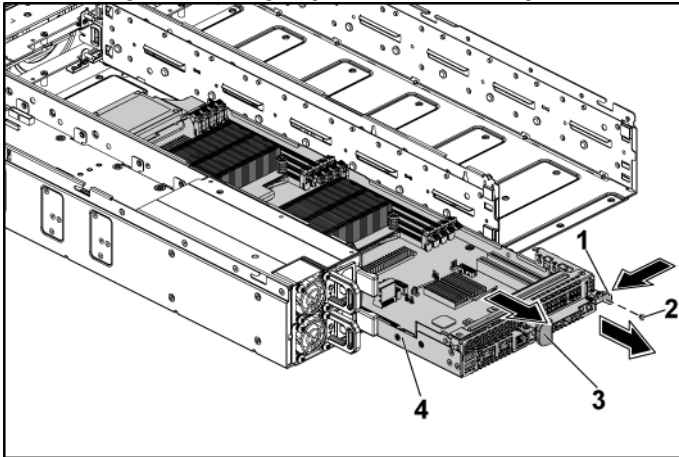

- | | | | |
|---|-----------------|---|-----------------------|
| 1 | retaining latch | 2 | screw |
| 3 | handle | 4 | system-board assembly |

Installing a System-Board Assembly



CAUTION: Many repairs may only be done by a certified service technician. You should only perform troubleshooting and simple repairs as authorized in your product documentation, or as directed by the online or telephone service and support team. Damage due to servicing that is not authorized by Dell is not covered by your warranty. Read and follow the safety instructions that came with the product.

- 1 Slide the system-board assembly into the chassis until it snaps into place. See Figure 3-9.
- 2 Reconnect all the external cables to the system board.
- 3 Replace the screw that secures the retaining latch. See Figure 3-9.
- 4 Turn on the system board by pressing the power button on the back panel, and the attached peripherals.



NOTE: Contact technical support to add the service tag of the system board to match the service tag of the physical node.

Air Baffle

Removing the Air Baffle



CAUTION: Many repairs may only be done by a certified service technician. You should only perform troubleshooting and simple repairs as authorized in your product documentation, or as directed by the online or telephone service and support team. Damage due to servicing that is not authorized by Dell is not covered by your warranty. Read and follow the safety instructions that came with the product.

- 1 Remove the system-board assembly. See “Removing a System-Board Assembly” on page 142.
- 2 When removing the air baffle for 2U node, the expansion-card assembly for 2U node must be removed first. See Figure 3-17.
- 3 Lift the two air baffles out of the system-board assembly. See Figure 3-10.

Figure 3-10. Removing and Installing the Air Baffles

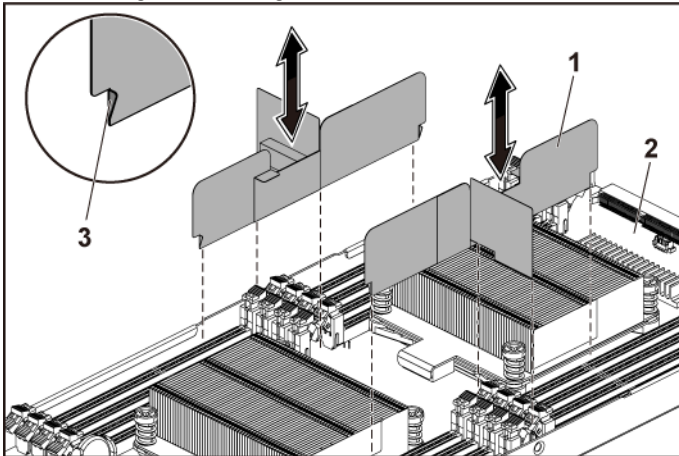

- 1 air baffle (2)
- 2 system-board assembly
- 3 hook (4)

Installing the Air Baffle



CAUTION: Many repairs may only be done by a certified service technician. You should only perform troubleshooting and simple repairs as authorized in your product documentation, or as directed by the online or telephone service and support team. Damage due to servicing that is not authorized by Dell is not covered by your warranty. Read and follow the safety instructions that came with the product.

- 1 Replace the two air baffles into the system-board assembly. Make sure that the hooks are properly engaged with the heat sink bases. See Figure 3-10.
- 2 Replace the system-board assembly. See "Installing a System-Board Assembly" on page 143.

Heat Sinks

Removing the Heat Sink



CAUTION: Many repairs may only be done by a certified service technician. You should only perform troubleshooting and simple repairs as authorized in your product documentation, or as directed by the online or telephone service and support team. Damage due to servicing that is not authorized by Dell is not covered by your warranty. Read and follow the safety instructions that came with the product.



NOTE: Please place the foolproof pins of two processor heatsinks facing inside.

- 1 Remove the system-board assembly. See "Removing a System-Board Assembly" on page 142.



WARNING: The heat sink may be hot to touch for some time after the system has been powered down. Allow the heat sink to cool before removing it.



CAUTION: Never remove the heat sink from a processor unless you intend to remove the processor. The heat sink is necessary to maintain proper thermal conditions.

- 2 Using a Phillips screwdriver, loosen one of the heat-sink retention screws. See Figure 3-11.
Wait for 30 seconds for the heat sink to loosen from the processor.
- 3 Remove the other three heat-sink retention screws.
- 4 Gently lift the heat sink off the processor and set the heat sink aside with thermal grease side facing up.

Figure 3-11. Removing and Installing the Heat Sink

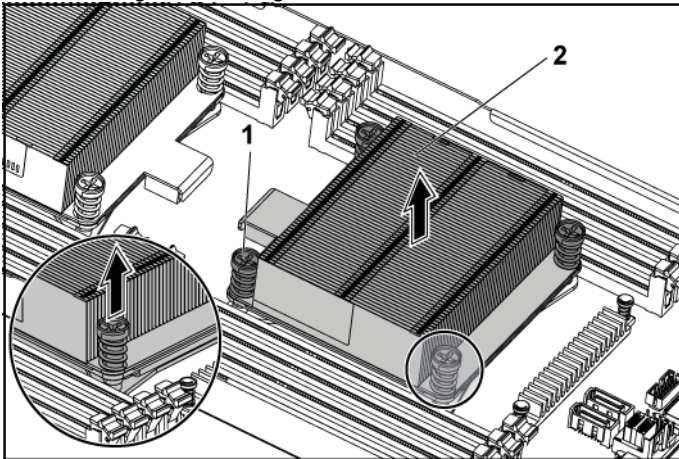

1 screw (4)

2 heat sink

Installing the Heat Sink



CAUTION: Many repairs may only be done by a certified service technician. You should only perform troubleshooting and simple repairs as authorized in your product documentation, or as directed by the online or telephone service and support team. Damage due to servicing that is not authorized by Dell is not covered by your warranty. Read and follow the safety instructions that came with the product.

- 1 Using a clean lint-free cloth, remove the thermal grease from the heat sink.

- 2 Apply new thermal grease evenly to the center of the top of the new processor.



CAUTION: Using excess thermal grease can cause grease to contact the processor shield, which can cause contamination of the processor socket.

- 3 Place the heat sink on the processor. See Figure 3-11.
- 4 Using a Phillips screwdriver, tighten the four heat-sink retention screws.
- 5 Replace the system-board assembly. See "Installing a System-Board Assembly" on page 143.

Processors

This system board supports dual Intel E5-2600 processor series, which is up to 135W, 3.5GHz and 12 cores, based on Intel Patsburg PCH chipset.

Removing a Processor



CAUTION: Many repairs may only be done by a certified service technician. You should only perform troubleshooting and simple repairs as authorized in your product documentation, or as directed by the online or telephone service and support team. Damage due to servicing that is not authorized by Dell is not covered by your warranty. Read and follow the safety instructions that came with the product.

- 1 Remove the system-board assembly. See "Removing a System-Board Assembly" on page 142.
- 2 Remove the heat sink, see "Removing the Heat Sink" on page 145.



CAUTION: The processor is held in its socket under strong pressure. Be aware that the release lever can spring up suddenly if not firmly grasped.

- 3 Position your thumb firmly over the processor socket-release lever and release the lever from the locked position. Rotate the lever 90 degrees upward until the processor is released from the socket. See Figure 3-12.
- 4 Rotate the processor shield upward and out of the way. See Figure 3-12.
- 5 Lift the processor out of the socket and leave the socket-release lever up so that the socket is ready for the new processor. See Figure 3-12.

CAUTION: Be careful not to bend any of the pins on the C socket when removing the processor. Bending the pins can permanently damage the system board. Be sure to properly align the process or notch to the socket and insert straight down. Do not move from side to side.

Figure 3-12. Removing and Installing a Processor

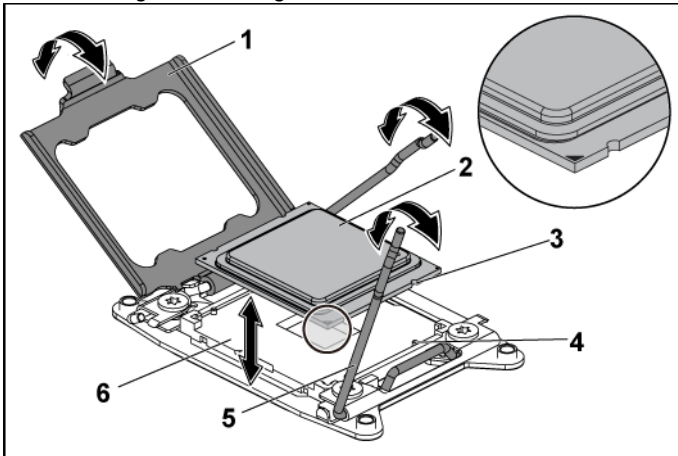

- | | | | |
|---|--------------------------|---|----------------|
| 1 | processor shield | 2 | processor |
| 3 | notch in processor (4) | 4 | socket key (4) |
| 5 | socket-release lever (2) | 6 | CPU socket |

Installing a Processor



CAUTION: Many repairs may only be done by a certified service technician. You should only perform troubleshooting and simple repairs as authorized in your product documentation, or as directed by the online or telephone service and support team. Damage due to servicing that is not authorized by Dell is not covered by your warranty. Read and follow the safety instructions that came with the product.



NOTE: When installing only one processor, the processor must be installed in the processor 0 (for the socket location, see “System Board Connectors” on page 294).



NOTE: If you are upgrading your processors, prior to upgrading your system, download and install the latest system BIOS version from support.dell.com. Follow the instructions included in the file download to install the update on your system.

- 1 Unpack the processor if it has not been used previously.
If the processor has already been used, remove any thermal grease from the top of the processor using a lint-free cloth.
- 2 Align the processor with the socket keys on the CPU socket. See Figure 3-12.



CAUTION: Positioning the processor incorrectly can permanently damage the system board or the processor. Be careful not to bend the pins in the CPU socket.

- 3 With the release lever on the processor socket in the open position, align the processor with the socket keys and set the processor lightly in the socket. See Figure 3-12.



CAUTION: Do not use force to seat the processor. When the processor is positioned correctly, it engages easily into the socket.

- 4 Close the processor shield.
- 5 Rotate the socket release lever down until it snaps into place.
- 6 Using a clean lint-free cloth, remove the thermal grease from the heat sink.
- 7 Apply thermal grease evenly to the center of the top of the new processor.



CAUTION: Using excess thermal grease can cause grease to contact the processor shield, which can cause contamination of the processor socket.

- 8 Place the heat sink on the processor. See Figure 3-11.
- 9 Using a Phillips screwdriver, tighten the heat-sink retention screws. See Figure 3-11.
- 10 Replace the system-board assembly. See "Installing a System-Board Assembly" on page 143.
- 11 Reconnect the system to its electrical outlet and turn on the system, including any attached peripherals.
- 12 Press <F2> to enter the System Setup program, and check that the processor information matches the new system configuration. See "System Setup Options at Boot" on page 58.

Interposer Extender for 2U Node



CAUTION: Many repairs may only be done by a certified service technician. You should only perform troubleshooting and simple repairs as authorized in your product documentation, or as directed by the online or telephone service and support team. Damage due to servicing that is not authorized by Dell is not covered by your warranty. Read and follow the safety instructions that came with the product.



NOTE: This section is applicable to systems with 2U node only.

Removing the Interposer Extender for 2U Node

- 1 Remove the system-board assembly. See “Removing a System-Board Assembly” on page 142.
- 2 Disconnect all the cables from the interposer extender. See Figure 5-10.

- 3 Remove the screws that secure the interposer extender to the interposer-extender tray. See Figure 3-13.
- 4 Lift the interposer extender out of the interposer-extender tray. See Figure 3-13.

Figure 3-13. Removing and Installing the Interposer Extender for 2U Node

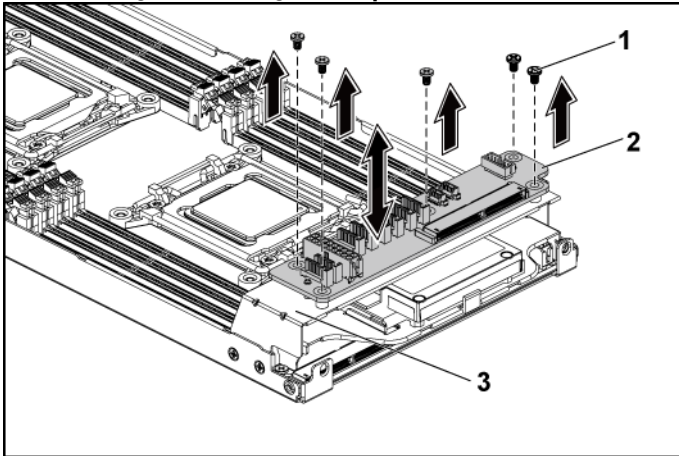

- | | | | |
|---|--------------------------|---|---------------------|
| 1 | screw (5) | 2 | interposer extender |
| 3 | interposer-extender tray | | |

Installing the Interposer Extender for 2U Node





CAUTION: Many repairs may only be done by a certified service technician. You should only perform troubleshooting and simple repairs as authorized in your product documentation, or as directed by the online or telephone service and support team. Damage due to servicing that is not authorized by Dell is not covered by your warranty. Read and follow the safety instructions that came with the product.

- 1 Place the interposer extender into the interposer-extender tray.
- 2 Replace the screws that secure the interposer extender to the interposer-extender tray.
- 3 Reconnect all the cables to the interposer extender. See Figure 5-10.
- 4 Replace the system-board assembly. See "Installing a System-Board

Assembly" on page 143.

Removing the Interposer Extender Tray for 2U Node

 **CAUTION:** Many repairs may only be done by a certified service technician. You should only perform troubleshooting and simple repairs as authorized in your product documentation, or as directed by the online or telephone service and support team. Damage due to servicing that is not authorized by Dell is not covered by your warranty. Read and follow the safety instructions that came with the product.

 **NOTE:** This section is applicable to systems with 2U node only.

- 1 Remove the system-board assembly. See “Removing a System-Board Assembly” on page 142.
- 2 Remove the interposer extender. See Figure 3-13.
- 3 Remove the screws that secure the interposer-extender tray to the system board. See Figure 3-14.
- 4 Lift the interposer-extender tray out of the system-board assembly. See Figure 3-14.

Figure 3-14. Removing and Installing the Interposer-Extender Tray

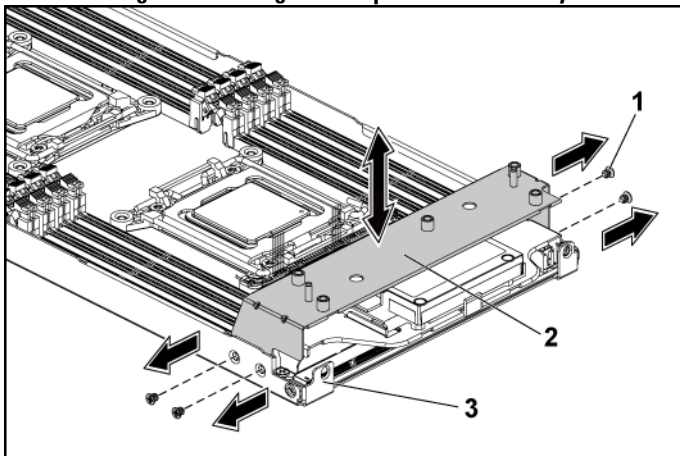

- | | | | |
|---|-----------------------|---|--------------------------|
| 1 | screw (4) | 2 | interposer-extender tray |
| 3 | system-board assembly | | |

Installing the Interposer Extender Tray for 2U Node Tray



CAUTION: Many repairs may only be done by a certified service technician. You should only perform troubleshooting and simple repairs as authorized in your product documentation, or as directed by the online or telephone service and support team. Damage due to servicing that is not authorized by Dell is not covered by your warranty. Read and follow the safety instructions that came with the product.

- 1 Place the interposer-extender tray into the system board. See Figure 3-14.
- 2 Replace the screws that secure the interposer extender tray to the system board. See Figure 3-14.
- 3 Replace the interposer extender. See Figure 3-13.
- 4 Connect all the cables to the interposer extender. See Figure 5-10.
- 5 Replace the system-board assembly. See "Installing a System-Board Assembly" on page 143.

Expansion-Card Assembly and Expansion Card

Removing the Expansion Card for 1U Node



CAUTION: Many repairs may only be done by a certified service technician. You should only perform troubleshooting and simple repairs as authorized in your product documentation, or as directed by the online or telephone service and support team. Damage due to servicing that is not authorized by Dell is not covered by your warranty. Read and follow the safety instructions that came with the product.

- 1 Remove the system-board assembly. See "Removing a System-Board Assembly" on page 142.

- 2 Remove the four screws that secure the expansion-card assembly. See Figure 3-15.
- 3 Lift the expansion-card assembly out of the system-board assembly. See Figure 3-15.

Figure 3-15. Removing the Expansion-Card Assembly for 1U Node

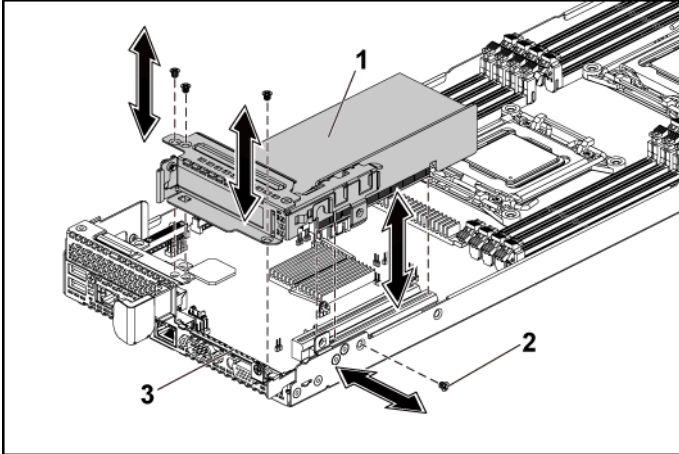

- | | | | |
|---|-------------------------|---|-----------|
| 1 | expansion-card assembly | 2 | screw (4) |
| 3 | system-board assembly | | |

- 4 Remove the screw securing the expansion card. See Figure 3-16.
- 5 Grasp the expansion card by its edges, and carefully remove it from the riser card. See Figure 3-16.

If you are removing the card permanently, install an expansion-card slot cover over the empty expansion slot opening, and close the expansion-card latch. See. Figure 3-16



NOTE: You must install a filler bracket over an empty expansion slot to maintain Federal Communications Commission (FCC) certification of the system. The brackets also keep dust and dirt out of the system and aid in proper cooling and airflow inside the system.

Figure 3-16. Removing the Expansion Card for 1U Node

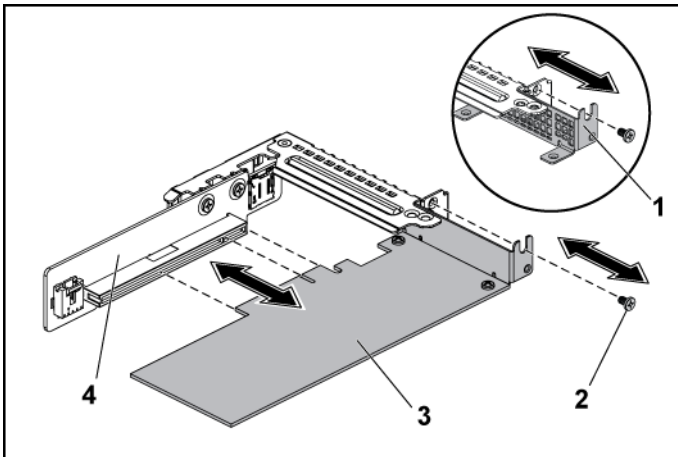

- | | | | |
|---|---------------------------|---|------------|
| 1 | expansion-card slot cover | 2 | screw |
| 3 | expansion card | 4 | riser card |

Installing the Expansion Card for 1U Node



CAUTION: Many repairs may only be done by a certified service technician. You should only perform troubleshooting and simple repairs as authorized in your product documentation, or as directed by the online or telephone service and support team. Damage due to servicing that is not authorized by Dell is not covered by your warranty. Read and follow the safety instructions that came with the product.



CAUTION: Expansion cards can only be installed in the slots on the expansion-card riser. Do not attempt to install expansion cards directly into the riser connector on the system board.

- 1 Unpack the expansion card and prepare it for installation. For instructions, see the documentation accompanying the card.
- 2 Remove the system-board assembly. See "Removing a System-Board Assembly" on page 142.
- 3 Remove the four screws that secure the expansion-card assembly.
- 4 Lift the expansion-card assembly away from the system-board assembly.
- 5 Remove the screw securing the filler bracket.
- 6 Grasp the filler bracket by its edges, and carefully remove it from the riser card.



NOTE: Keep this bracket in case you need to remove the expansion card. Filler brackets must be installed over empty expansion-cards slots to maintain FCC certification of the system. The brackets also keep dust and dirt out of the system and aid in proper cooling and airflow inside the system.

- 7 Holding the card by its edges, position the card so that the card-edge connector aligns with the riser card on the expansion-card assembly.
- 8 Insert the card-edge connector firmly into the riser card until the card is fully seated.
- 9 Replace the screw securing the expansion card.
- 10 Place the expansion-card assembly into the system-board assembly.
- 11 Replace the four screws that secure the expansion-card assembly.
- 12 Replace the system-board assembly. See "Installing a System-Board

Assembly" on page 143.

Removing the Expansion Card for 2U Node

△ CAUTION: Many repairs may only be done by a certified service technician. You should only perform troubleshooting and simple repairs as authorized in your product documentation, or as directed by the online or telephone service and support team. Damage due to servicing that is not authorized by Dell is not covered by your warranty. Read and follow the safety instructions that came with the product.

- 1 Remove the system-board assembly. See "Removing a System-Board Assembly" on page 142.
- 2 Remove the five screws that secure the expansion-card assembly. See Figure 3-17.
- 3 Lift the expansion-card assembly out of the system-board assembly. See Figure 3-17.

Figure 3-17. Removing the Expansion-Card Assembly for 2U Node

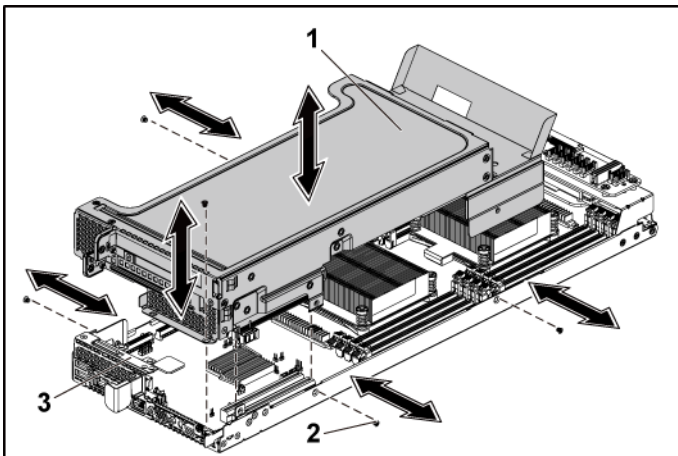

- | | | | |
|---|-------------------------|---|-----------|
| 1 | expansion-card assembly | 2 | screw (5) |
| 3 | system-board assembly | | |

- 4 Remove the four screws securing the expansion-card lock cover. See

Figure 3-18.

- 5 Remove the expansion-card lock cover. See Figure 3-18.

Figure 3-18. Removing the Expansion-card Lock Cover for 2U Node

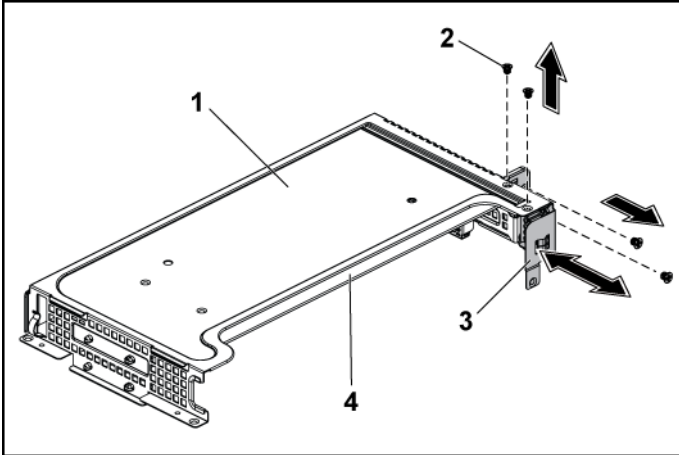

- | | | | |
|---|---------------------------|---|----------------|
| 1 | expansion-card assembly | 2 | screw (4) |
| 3 | expansion-card lock cover | 4 | expansion card |

- 6 Remove the screw securing the expansion card. See Figure 3-19.
- 7 Grasp the expansion card by its edges, and carefully remove it from the riser card. See Figure 3-19.

If you are removing the card permanently, install a metal filler bracket over the empty expansion slot opening, and close the expansion-card latch. See Figure 3-19.



NOTE: You must install a filler bracket over an empty expansion slot to maintain Federal Communications Commission (FCC) certification of the system. The brackets also keep dust and dirt out of the system and aid in proper cooling and airflow inside the system.

Figure 3-19. Removing the Expansion Card for 2U Node

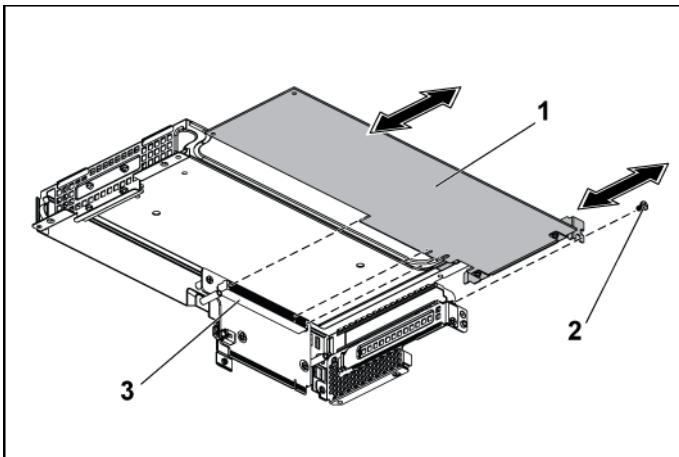

- 1 expansion card
- 3 riser card

- 2 screw

- 8 Install the expansion-card slot cover and screw securing the expansion-card bracket. See Figure 3-20.

Figure 3-20. Installing the Expansion-card Slot Cover for 2U Node

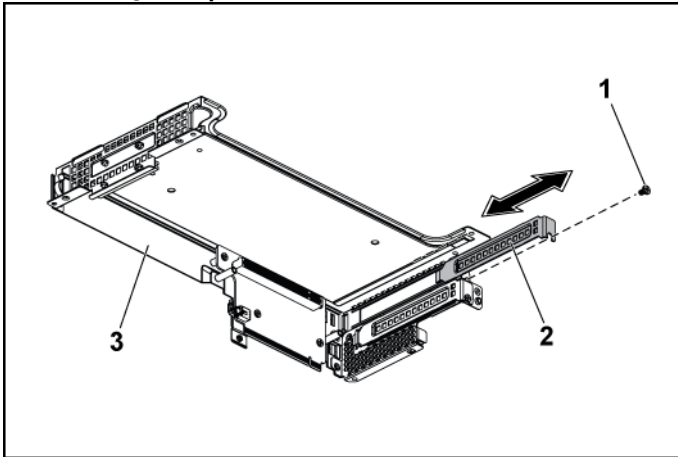

- | | | | |
|---|------------------------|---|---------------------------|
| 1 | screw | 2 | expansion-card slot cover |
| 3 | expansion-card bracket | | |

- 9 Install the expansion-card lock cover and screws securing to the expansion card bracket. See Figure 3-21.

Figure 3-21. Installing the Expansion-card Lock Cover for 2U Node

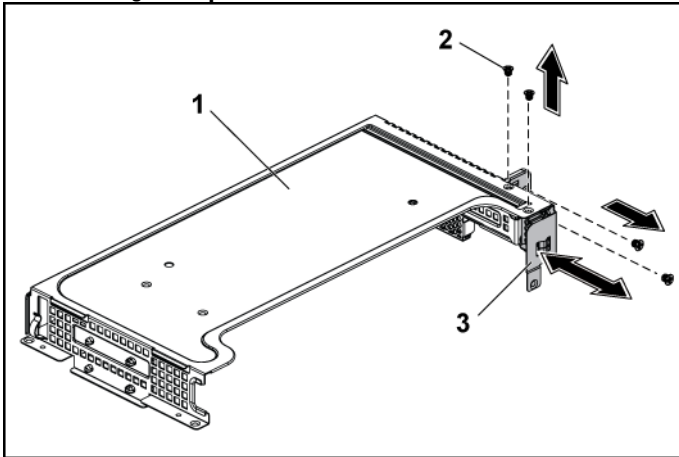

- | | | | |
|---|---------------------------|---|-----------|
| 1 | expansion-card bracket | 2 | screw (4) |
| 3 | expansion-card lock cover | | |

Installing the Expansion Card for 2U Node



CAUTION: Many repairs may only be done by a certified service technician. You should only perform troubleshooting and simple repairs as authorized in your product documentation, or as directed by the online or telephone service and support team. Damage due to servicing that is not authorized by Dell is not covered by your warranty. Read and follow the safety instructions that came with the product.



CAUTION: Expansion cards can only be installed in the slots on the expansion-card riser. Do not attempt to install expansion cards directly into the riser connector on the system board.

- 1 Unpack the expansion card and prepare it for installation. For instructions, see the documentation accompanying the card.
- 2 It is recommended to turn off the system, including any attached peripherals, and disconnect the system from its electrical outlet.
- 3 Remove the system-board assembly. See “Removing a System-Board

Assembly" on page 142.

- 4 Remove the four screws that secure the expansion-card assembly.
- 5 Lift the expansion-card assembly away from the system-board assembly.
- 6 Remove the screw securing the filler bracket.
- 7 Grasp the filler bracket by its edges, and carefully remove it from the riser card.



NOTE: Keep this bracket in case you need to remove the expansion card. Filler brackets must be installed over empty expansion-cards slots to maintain FCC certification of the system. The brackets also keep dust and dirt out of the system and aid in proper cooling and airflow inside the system.

- 8 Holding the expansion card by its edges, position the card so that the card-edge connector aligns with the riser card.
- 9 Insert the card-edge connector firmly into the riser card until the card is fully seated.
- 10 Install the expansion slot lock cover by securing the four screws.
- 11 Place the expansion-card assembly into the system-board assembly.
- 12 Replace the screws that secure the expansion-card assembly.
- 13 Replace the system-board assembly. See "Installing a System-Board Assembly" on page 143.

Raid Card

The installation and removal procedures and cable routing for the Raid Cards including LSI 9265-8i with BBU, LSI 9210-8i HBA and LSI 9285-8e with BBU are similar; please refer to the indications for details.

Summary of LSI 9265-8i with RAID Battery, LSI 9210-8i HBA and LSI 9285-8e with RAID Battery

	Card Removal and Installation	BBU Removal and Installation	Cable Plan
LSI 9265-8i with RAID Battery	See “LSI 9265-8i Card”	See “LSI 9265-8i RAID Battery”	Cable required for 1U Node: <ul style="list-style-type: none"> • Mini-SAS cable • Mini-SAS /SGPIO cable • RAID battery cable Cable required for 2U Node: <ul style="list-style-type: none"> • Mini-SAS /SGPIO cable • Mini-SAS cable • RAID battery cable • Power cable
LSI 9210-8i HBA	Same as LSI 9265-8i, see “LSI 9265-8i Card”	No RAID Battery	Cable required for 1U Node: <ul style="list-style-type: none"> • Mini-SAS cable • Mini-SAS /SGPIO cable Cable required for 2U node: <ul style="list-style-type: none"> • Mini-SAS cable • Mini-SAS /SGPIO cable • Power cable
LSI 9285-8e with RAID Battery	Same as Expansion-Card, see Figure 3-16 and Figure 3-19	Same as LSI 9265-8i, See “LSI 9265-8i RAID Battery”	Cable required for 1U Node: <ul style="list-style-type: none"> • RAID battery cable Cable required for 2U Node: <ul style="list-style-type: none"> • RAID battery cable • Power cable

Cable Routing

- For cable routing inside 1U node, see “Cable Routing for LSI 9265-8i Card (1U Node)”.
- For cable routing inside 2U node, see “Cable Routing for LSI 9265-8i Card (2U Node)”.

8i Card (2U Node)”

LSI 9265-8i Card



NOTE: The LSI 9265-8i card assembly should include the BBU interposer card which is connected to the RAID battery. The illustrations in this section are just for your removal and installation reference. For more information of the RAID battery, see “LSI 9265-8i RAID Battery” on page 178.

Removing the LSI 9265-8i Card for 1U Node



CAUTION: Many repairs may only be done by a certified service technician. You should only perform troubleshooting and simple repairs as authorized in your product documentation, or as directed by the online or telephone service and support team. Damage due to servicing that is not authorized by Dell is not covered by your warranty. Read and follow the safety instructions that came with the product.

- 1 Remove the system-board assembly. See “Removing a System-Board Assembly” on page 142.
- 2 Disconnect the two SAS/SGPIO cables connecting to the LSI 9265-8i card assembly.

- 3 Remove the screws that secure the LSI 9265-8i card assembly. See Figure 3-22.
- 4 Lift the LSI 9265-8i card assembly out of the system-board assembly. See Figure 3-22.

Figure 3-22. Removing the LSI 9265-8i Card Assembly for 1U Node

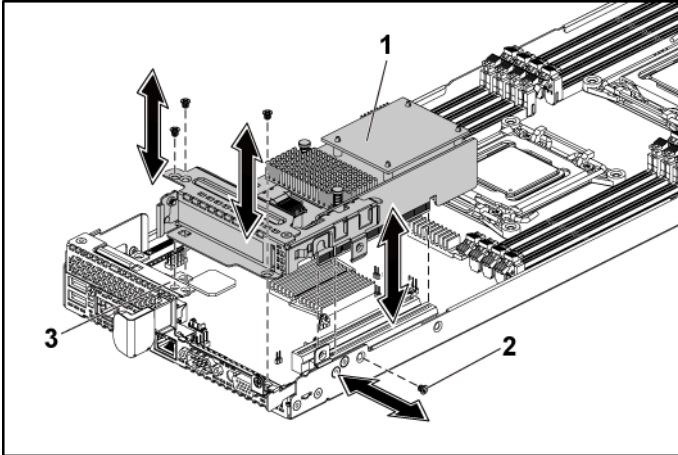

- | | | | |
|---|---------------------------|---|-----------|
| 1 | LSI 9265-8i-card assembly | 2 | screw (4) |
| 3 | system-board assembly | | |

- 5 Remove the screw securing the LSI 9265-8i card. See Figure 3-23.
- 6 Grasp the LSI 9265-8i card by its edges, and carefully remove it from the riser card. See Figure 3-23.

If you are removing the card permanently, install an expansion-card slot cover over the empty expansion slot opening, and close the expansion-card latch.



NOTE: You must install a filler bracket over an empty expansion slot to maintain Federal Communications Commission (FCC) certification of the system. The brackets also keep dust and dirt out of the system and aid in proper cooling and airflow inside the system.

Figure 3-23. Removing the LSI 9265-8i Card

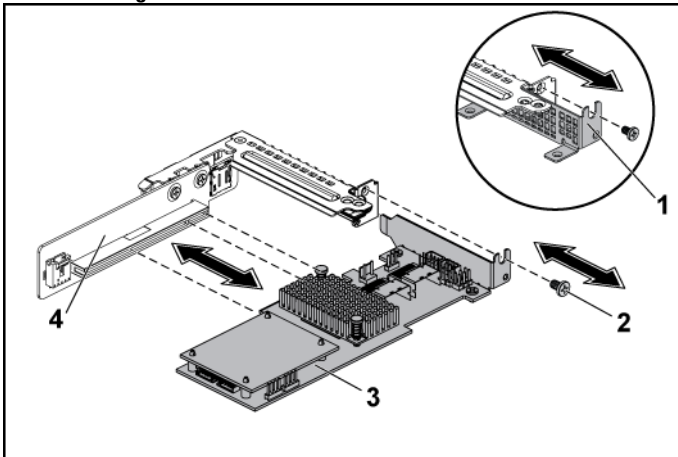

- | | | | |
|---|---------------------------|---|------------|
| 1 | expansion-card slot cover | 2 | screw |
| 3 | LSI 9265-8i card | 4 | riser card |

Installing the LSI 9265-8i Card for 1U Node



CAUTION: Many repairs may only be done by a certified service technician. You should only perform troubleshooting and simple repairs as authorized in your product documentation, or as directed by the online or telephone service and support team. Damage due to servicing that is not authorized by Dell is not covered by your warranty. Read and follow the safety instructions that came with the product.



CAUTION: Expansion cards can only be installed in the slots on the expansion-card riser. Do not attempt to install expansion cards directly into the riser connector on the system board.



CAUTION: Not to apply any pressure to heat sinks on expansion cards.

- 1 Unpack the LSI 9265-8i card and prepare it for installation. For instructions, see the documentation accompanying the card.
- 2 Remove the system-board assembly. See “Removing a System-Board Assembly” on page 142.
- 3 Connect the RAID battery cable to the BBU interposer card. See Figure 3-24.
- 4 Remove the screw securing the filler bracket. Grasp the filler bracket by its edges, and carefully remove it from the riser card.



NOTE: Keep this bracket in case you need to remove the expansion card. Filler brackets must be installed over empty expansion-cards slots to maintain FCC certification of the system. The brackets also keep dust and dirt out of the system and aid in proper cooling and airflow inside the system.

- 5 Connect the mini-SAS/SGPIO cables to the LSI 9265-8i card assembly. See Figure 3-24.
- 6 Holding the card by its edges, position the card so that the card-edge connector aligns with the riser card.
- 7 Insert the card-edge connector firmly into the riser card until the card is fully seated.
- 8 Replace the screw securing the LSI 9265-8i card.
- 9 Place the LSI 9265-8i card assembly into the system-board assembly.

- 10 Replace the four screws that secure the LSI 9265-8i card assembly.
- 11 Install the system-board assembly. See "Installing a System-Board Assembly" on page 143.

Cable Routing for LSI 9265-8i Card (1U Node)

- 1 Connect the mini-SAS cable to the LSI 9265-8i card, and connect the other end of the cable to the corresponding connector on the system board.
- 2 Connect the mini-SAS&SGPIO cable to the LSI 9265-8i card, and connect the other end of the cable to the corresponding connectors on the system board. Ensure the cables should go through the cable clip ring. See Figure 3-24.
- 3 Connect the RAID battery cable to the BBU interposer card on the LSI 9265-8i card, and connect the other end of the cable to the corresponding connector on the RAID battery.



NOTE: When connecting the RAID battery cable, the BBU interposer card should be installed on the LSI 9265-8i card. The BBU interposer card in the figure below is just for you reference.

Figure 3-24. Cable Routing for LSI 9265-8i Card (1U Node)

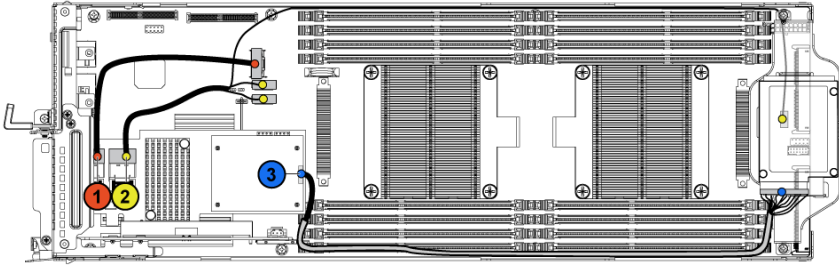

Item	Cable	From (LSI 9265-8i Card)	To (RAID Battery and System Board)
①	Mini-SAS cable	Mini-SAS connector 0~3 (J2B1)	Mini-SAS connector 0
②	Mini-SAS /SCPIO cable	Mini-SAS connector 4~7 (J2B2)	Onboard SATAII connectors 4&5 and SCPIO 2
③	RAID battery cable	RAID battery connector (J4)	RAID battery connector

Removing the LSI 9265-8i Card for 2U Node



NOTE: The LSI 9265-8i card assembly should include the BBU interposer card which is connected to the LSI 9265-8i RAID battery. The illustrations in this section are just for your removal and installation reference. For more information of the LSI 9265-8i RAID battery, see “LSI 9265-8i RAID Battery” on page 180.



CAUTION: Many repairs may only be done by a certified service technician. You should only perform troubleshooting and simple repairs as authorized in your product documentation, or as directed by the online or telephone service and support team. Damage due to servicing that is not authorized by Dell is not covered by your warranty. Read and follow the safety instructions that came with the product.



NOTE: The LSI 9265-8i card can be supported only on the 1.5U riser card. For the information of the riser card, see “Removing the Riser card for 2U Node” on page 188.

- 1 Remove the system-board assembly. See “Removing a System-Board Assembly” on page 142.
- 2 Disconnect the two SAS/SGPIO cables connecting to the LSI 9265-8i card assembly.

- 3 Remove the five screws that secure the LSI 9265-8i card assembly. See Figure 3-25.
- 4 Lift the LSI 9265-8i card assembly out of the system-board assembly. See Figure 3-25.

Figure 3-25. Removing the LSI 9265-8i Card Assembly for 2U Node

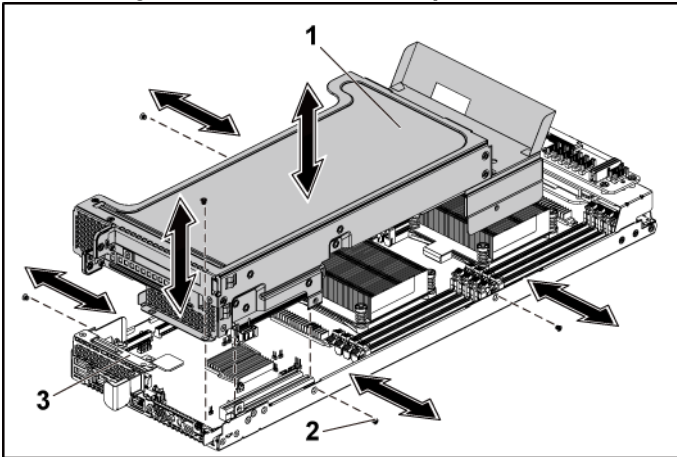

- 1 LSI 9265-8i-card assembly
- 3 system-board assembly

2 screw (5)

- 5 Remove the four screws securing the LSI 9265-8i card lock cover. See Figure 3-26.
- 6 Remove the LSI 9265-8i card lock cover. See Figure 3-26.

Figure 3-26. Removing the LSI 9265-8i Card Lock Cover

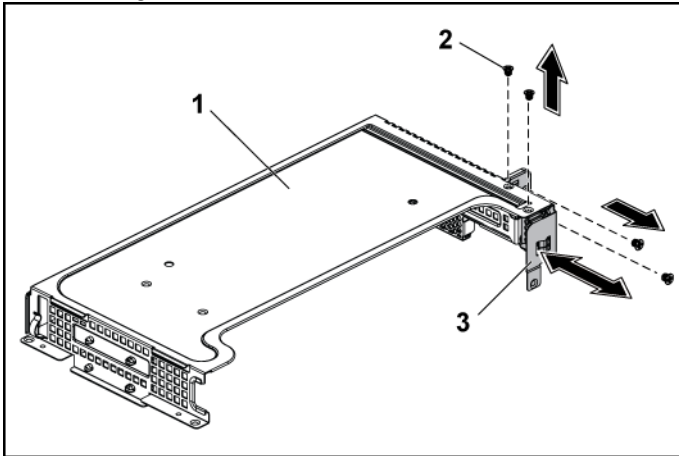

- 1 LSI 9265-8i-card assembly
- 3 expansion-card lock cover

2 screws (4)

- 7 Remove the screw securing the LSI 9265-8i card. See Figure 3-27.
- 8 Grasp the LSI 9265-8i card by its edges, and carefully remove it from the riser card. See Figure 3-27.

If you are removing the card permanently, install a metal filler bracket over the empty expansion slot opening, and close the expansion-card latch.



NOTE: You must install a filler bracket over an empty expansion slot to maintain Federal Communications Commission (FCC) certification of the system. The brackets also keep dust and dirt out of the system and aid in proper cooling and airflow inside the system.

Figure 3-27. Removing the LSI 9265-8i Card

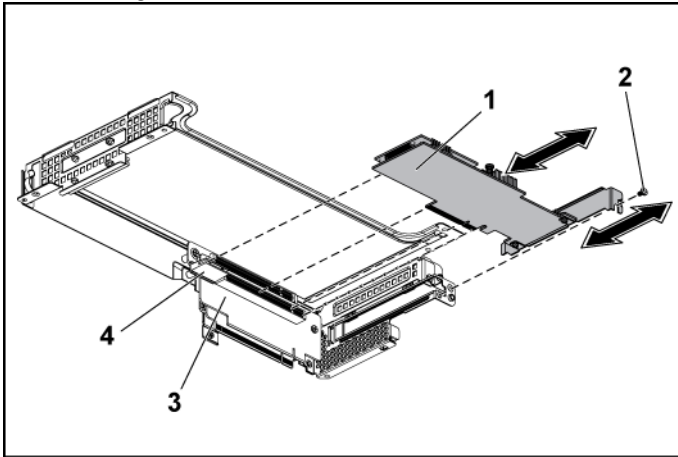

- | | | | |
|---|------------------|---|-------------|
| 1 | LSI 9260-8i card | 2 | screw |
| 3 | riser card | 4 | card holder |

Installing the LSI 9265-8i Card for 2U Node



CAUTION: Many repairs may only be done by a certified service technician. You should only perform troubleshooting and simple repairs as authorized in your product documentation, or as directed by the online or telephone service and support team. Damage due to servicing that is not authorized by Dell is not covered by your warranty. Read and follow the safety instructions that came with the product.



CAUTION: Expansion cards can only be installed in the slots on the expansion-card riser. Do not attempt to install expansion cards directly into the riser connector on the system board.

- 1 Unpack the LSI 9265-8i card and prepare it for installation. For instructions, see the documentation accompanying the card.
- 2 Remove the system-board assembly. See “Removing a System-Board Assembly” on page 142.
- 3 Connect the RAID battery cable to the BBU interposer card. See Figure 3-28.
- 4 Remove the screw securing the filler bracket. Grasp the filler bracket by its edges, and carefully remove it from the riser card.



NOTE: Keep this bracket in case you need to remove the expansion card. Filler brackets must be installed over empty expansion-cards slots to maintain FCC certification of the system. The brackets also keep dust and dirt out of the system and aid in proper cooling and airflow inside the system.

- 5 Connect the mini-SAS/SGPIO cables to the LSI 9265-8i card assembly. See Figure 3-28.
- 6 Holding the card by its edges, position the card so that the card-edge connector aligns with the riser card.
- 7 Insert the card-edge connector firmly into the riser card until the card is fully seated.
- 8 Install the expansion slot lock cover by securing the three screws.
- 9 Place the LSI 9265-8i card assembly into the system-board assembly.
- 10 Replace the four screws that secure the LSI 9265-8i card assembly.

- 11 Install the system-board assembly. See “Installing a System-Board Assembly” on page 143.

Cable Routing for LSI 9265-8i Card (2U Node)

- 1 Connect the mini-SAS&SGPIO cable to the LSI 9265-8i card, and connect the other end of the cable to the corresponding connectors on the interposer extender. Ensure the cables should go through the cable clip ring. See Figure 3-28.
- 2 Connect the mini-SAS cable to the LSI 9265-8i card, and connect the other end of the cable to the corresponding connector on the system board. Ensure the cables should go through the cable clip ring. See Figure 3-28.
- 3 Connect the RAID battery cable to the BBU interposer card on the LSI 9265-8i card, and connect the other end of the cable to the corresponding connector on the RAID battery. See Figure 3-28.
- 4 Connect the power cable to the interposer extender for 2U node, and connect the other end of the cable to the corresponding connector on the system board. See Figure 3-28.



NOTE: When connecting the RAID battery cable, the BBU interposer card should be installed on the LSI 9265-8i card. The BBU interposer card in the figure below is just for you reference.

Figure 3-28. Cable Routing for LSI 9265-8i Card

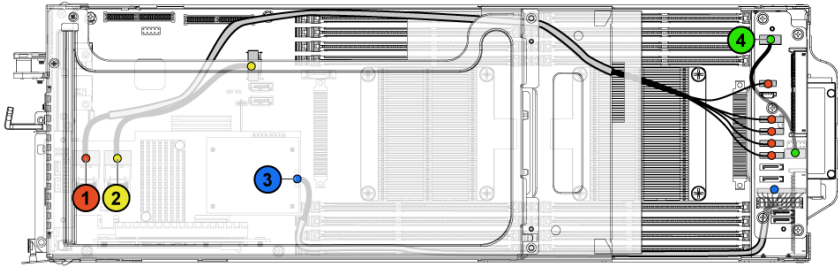

Item	Cable	From (LSI 9265-8i Card)	To (RAID Battery and Hard Drive to Backplane SATAII Connectors)
1	Mini-SAS /SGPIO cable	Mini-SAS connector 0~3 (J2B1)	SATAII connectors 0~3 and SGPIO 1 on the interposer extender for 2U node
2	Mini-SAS cable	Mini-SAS connector 4~7 (J2B2)	Mini-SAS connector 0 on the system board
3	RAID battery cable	RAID battery connector (J4)	RAID battery connector on the RAID battery
4	power cable	Control connector (J3) on the interposer extender	Front panel connector 1 on the system board

- 5 Press down on the cables, and ensure the cables are routed lower than the height of the expansion card assembly for the 2U node.

Figure 3-29. Cable Routing Down (2U Node)

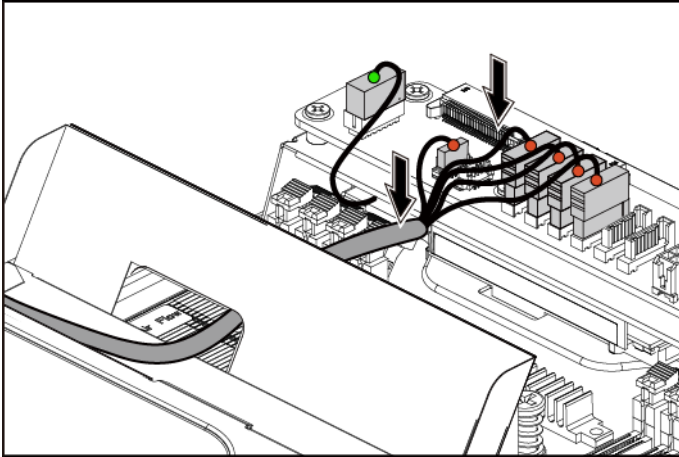

When securing the cable tie, make the cable tie go through the second air hole (from the bottom to the top) and then tighten it to encircle one of the mini-SAS cables. And meanwhile ensure the other mini-SAS cable is held by the cable-tie clip.

Figure 3-30. Cable Tie for 2U Node

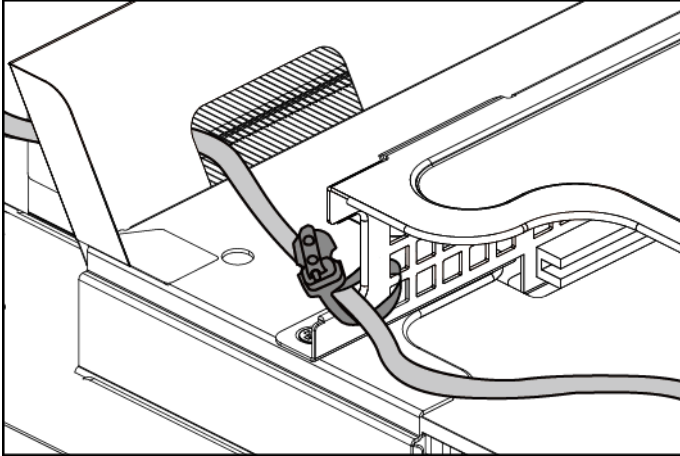

LSI 9265-8i RAID Battery

Removing the LSI 9265-8i raid battery Assembly



CAUTION: Many repairs may only be done by a certified service technician. You should only perform troubleshooting and simple repairs as authorized in your product documentation, or as directed by the online or telephone service and support team. Damage due to servicing that is not authorized by Dell is not covered by your warranty. Read and follow the safety instructions that came with the product.



NOTE: The information in this section applies only to systems intalled with the LSI 9265-8i card.

- 1 Remove the system-board assembly. See “Removing a System-Board Assembly” on page 142.
- 2 When removing the LSI 9265-8i RAID battery assembly for 1U node, skip to step 5; for 2U node, continue the steps.
- 3 Remove the interposer extender. See “Removing the Interposer Extender” on page 151.
- 4 Remove the interposer extender tray. See “Removing the Interposer Extender Tray” on page 153.
- 5 Disconnect the cable connecting to the LSI 9265-8i card.
- 6 Remove the screws that secure the LSI9265-8i RAID battery assembly to the system board. See Figure 3-31.
- 7 Lift the LSI 9265-8i RAID battery assembly away from the system board. See Figure 3-31.

Figure 3-31. Removing and Installing the LSI 9265-8i RAID Battery Assembly

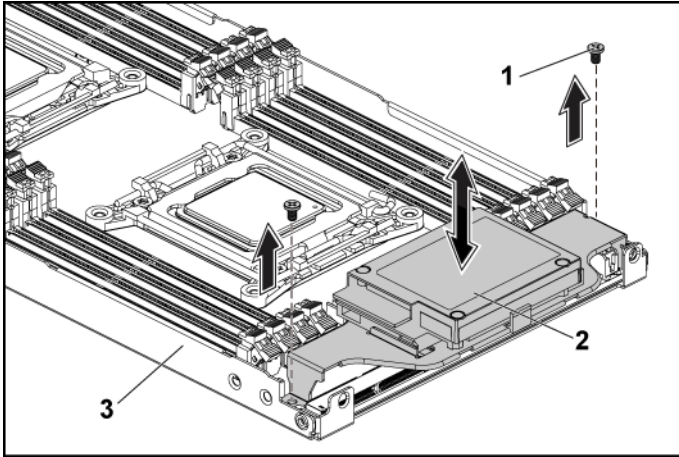

- 1 screws (2)
- 2 LSI 9265-8i RAID battery assembly
- 3 system-board assembly

Installing the LSI 9265-8i raid Battery Assembly

- 1 Attach the LSI9265-8i RAID battery assembly onto the system board. See Figure 3-31.
- 2 Replace the screws securing the LSI9265-8i RAID battery assembly. See Figure 3-31.
- 3 Connect the cable connecting to the LSI 9265-8i card.
- 4 When replacing the LSI9265-8i RAID battery assembly for 1U node, skip to step 7; for 2U node, continue the steps.
- 5 Replace the interposer-extender tray. See “Removing the Interposer Extender Tray” on page 153.
- 6 Replace the interposer extender for 2U node. See “Removing the Interposer Extender for 2U Node” on page 151
- 7 Install the system-board assembly. See “Installing a System-Board Assembly” on page 143.

Removing the LSI 9265-8i RAID Battery



CAUTION: Many repairs may only be done by a certified service technician. You should only perform troubleshooting and simple repairs as authorized in your product documentation, or as directed by the online or telephone service and support team. Damage due to servicing that is not authorized by Dell is not covered by your warranty. Read and follow the safety instructions that came with the product.



NOTE: The information in this section applies only to systems with the optional RAID controller card.

- 1 Remove the system-board assembly. See “Removing a System-Board Assembly” on page 142.
- 2 Disconnect the cable connecting to the LSI 9265-8i card.
- 3 When removing the LSI 9265-8i RAID battery for 1U node, skip to step 6; for 2U node, continue the steps.
- 4 Remove the interposer extender. See “Removing the Interposer Extender” on page 151.
- 5 Remove the interposer-extender tray. See “Removing the Interposer Extender Tray” on page 153.
- 6 Remove the LSI 9265-8i RAID battery assembly. See “Removing the LSI 9265-8i raid battery Assembly” on page 180.

- 7 Remove the screws securing the LSI 9265-8i RAID battery to the LSI9265-8i RAID battery carrier. See Figure 3-32.
Lift the LSI 9265-8i RAID battery carrier away from the LSI9265-8i RAID battery carrier. See Figure 3-32.

Figure 3-32. Removing and Installing the LSI 9265-8i RAID Battery

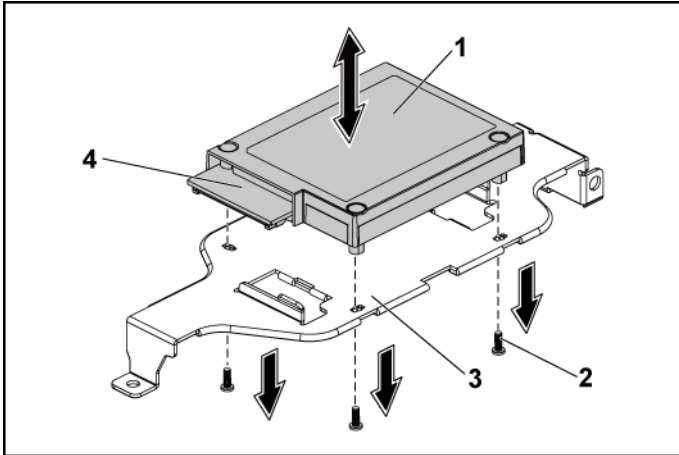

- | | | | |
|---|----------------------------------|---|------------------------|
| 1 | LSI 9265-8i RAID battery | 2 | screw (3) |
| 3 | LSI 9265-8i RAID battery carrier | 4 | RAID battery connector |

Installing the LSI 9265-8i RAID Battery

- 1 Place the LSI 9265-8i RAID battery in position on the LSI 9265-8i RAID battery carrier. See Figure 3-32.
- 2 Replace the screws securing the LSI 9265-8i RAID battery to the LSI 9265-8i RAID battery carrier. See Figure 3-32.
- 3 Install the LSI 9265-8i RAID battery into the LSI 9265-8i RAID battery carrier. See “Installing the LSI 9265-8i raid Battery” on page 181.
- 4 Reconnecting the cable connecting to the LSI 9265-8i card.
- 5 When replacing the LSI 9265-8i RAID battery for 1U node, skip to step 9; for 2U node, continue the steps.
- 6 Replace the interposer-extender tray. See “Removing the Interposer

Extender Tray” on page 153.

- 7 Replace the interposer extender. See “Removing the Interposer Extender” on page 151.
- 8 Install the system-board assembly. See “Installing a System-Board Assembly” on page 143.

Riser card

Optional Riser Cards

Figure 3-33. 1U Riser card for 1U Node

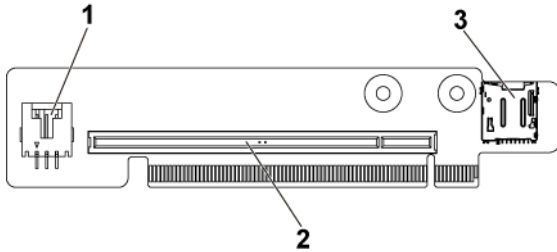

- | | | | |
|---|----------------------|---|-----------------|
| 1 | USB connector | 2 | PCI-E Gen 3 x16 |
| 3 | micro SD card socket | | |

Figure 3-34. 1.5U Riser card for 2U Node

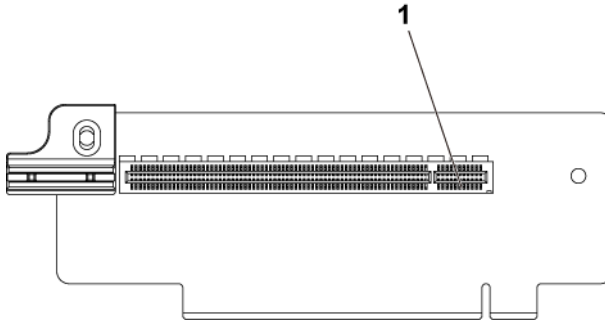

- | | |
|---|-----------------|
| 1 | PCI-E Gen 3 x16 |
|---|-----------------|

Figure 3-35. 2U Riser card for 2U Node

Front view

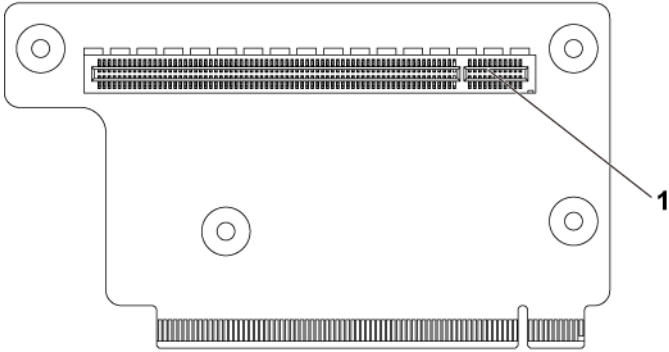

Back view

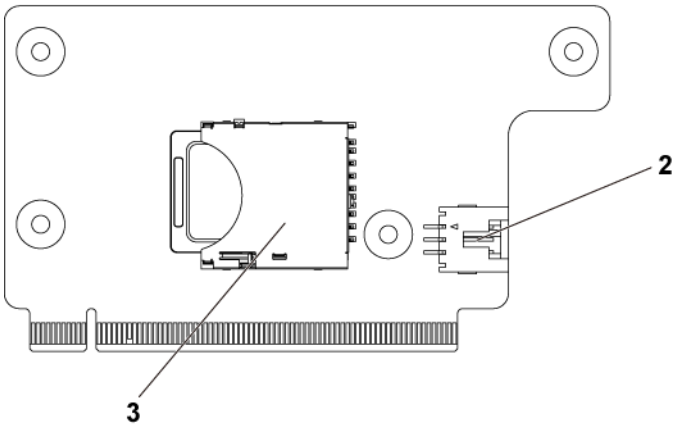

- 1 PCI-E Gen 3 x16
- 3 SD card socket

- 2 USB connector

Removing the Riser card for 1U Node



CAUTION: Many repairs may only be done by a certified service technician. You should only perform troubleshooting and simple repairs as authorized in your product documentation, or as directed by the online or telephone service and support team. Damage due to servicing that is not authorized by Dell is not covered by your warranty. Read and follow the safety instructions that came with the product.

- 1 Remove the system-board assembly. See “Removing a System-Board Assembly” on page 142.
- 2 Remove the expansion card. See “Removing the Expansion Card for 1U Node” on page 154.
- 3 Remove the two screws securing the riser card to the expansion-card bracket. See Figure 3-36.
- 4 Pull the riser card away from the expansion-card bracket. See Figure 3-36.

Figure 3-36. Removing and Installing the Riser card

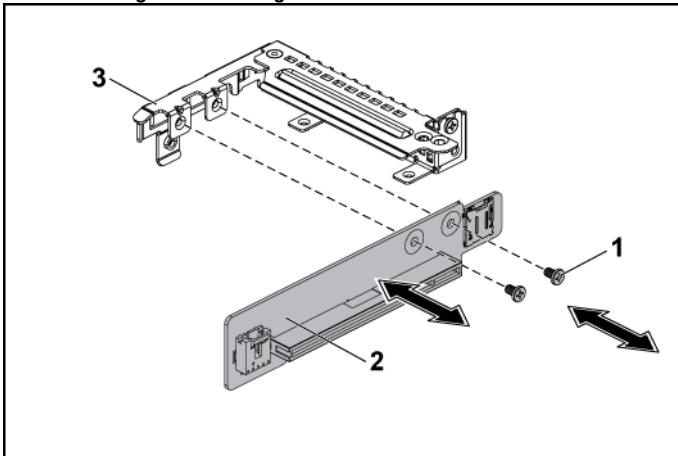

- | | | | |
|---|------------------------|---|------------|
| 1 | screw (2) | 2 | riser card |
| 3 | expansion-card bracket | | |

Installing the Riser card for 1U Node



CAUTION: Many repairs may only be done by a certified service technician. You should only perform troubleshooting and simple repairs as authorized in your product documentation, or as directed by the online or telephone service and support team. Damage due to servicing that is not authorized by Dell is not covered by your warranty. Read and follow the safety instructions that came with the product.

- 1 Place the riser card into the expansion-card bracket. See Figure 3-36.
- 2 Replace the two screws securing the riser card to the expansion-card bracket. See Figure 3-36.
- 3 Install the expansion card. See “Installing the Expansion Card for 1U Node” on page 157.
- 4 Replace the system-board assembly. See “Installing a System-Board Assembly” on page 143.

Cable Routing for Riser Card (1U Node)

- 1 Connect the USB cable to the 1U riser card, and connect the other end of the cable to the corresponding connectors on the system board. See Figure 3-37.

Figure 3-37. Cable Routing for 1U Riser Card USB Cable

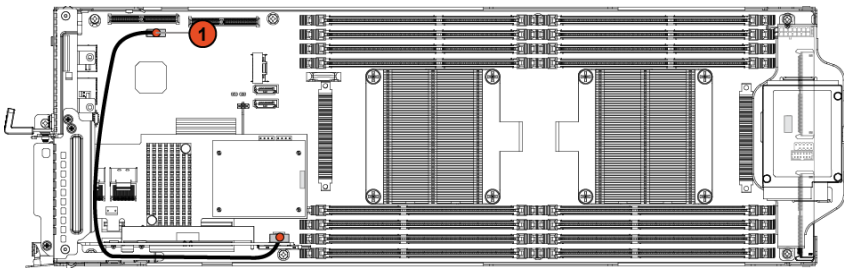

Item	Cable	From (Riser Card)	To (System Board)
1	USB cable	USB connector	internal USB connector

Removing the Riser card for 2U Node



CAUTION: Many repairs may only be done by a certified service technician. You should only perform troubleshooting and simple repairs as authorized in your product documentation, or as directed by the online or telephone service and support team. Damage due to servicing that is not authorized by Dell is not covered by your warranty. Read and follow the safety instructions that came with the product.



NOTE: Both 1.5U riser card and 2U riser card can be supported in the 2U-node system.

- 1 Remove the system-board assembly. See “Removing a System-Board Assembly” on page 142.
- 2 Remove the expansion card. See “Removing the Expansion Card for 2U Node” on page 158.

- 3 Turn the expansion-card bracket upward as shown in Figure 3-38 and Figure 3-39.
- 4 Remove the two screws securing the 1.5U riser card to the expansion-card bracket. See Figure 3-38.
- 5 Pull the 1.5U riser card away from the expansion-card bracket. See Figure 3-38.

Figure 3-38. Removing and Installing the 1.5U Riser card

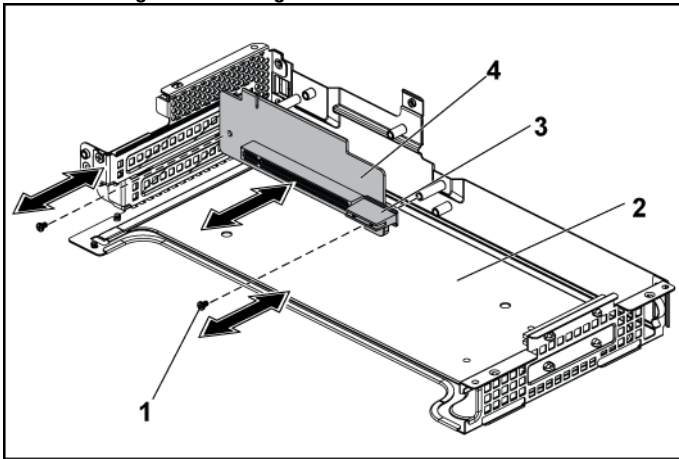

- | | | | |
|---|-------------|---|------------------------|
| 1 | screw (2) | 2 | expansion-card bracket |
| 3 | card holder | 4 | 1.5U riser card |

- 6 Remove the four screws securing the 2U riser card to the expansion-card bracket. See Figure 3-39.
- 7 Pull the 2U riser card away from the expansion-card racket. See Figure 3-39.

Figure 3-39. Removing and Installing the 2U Riser card

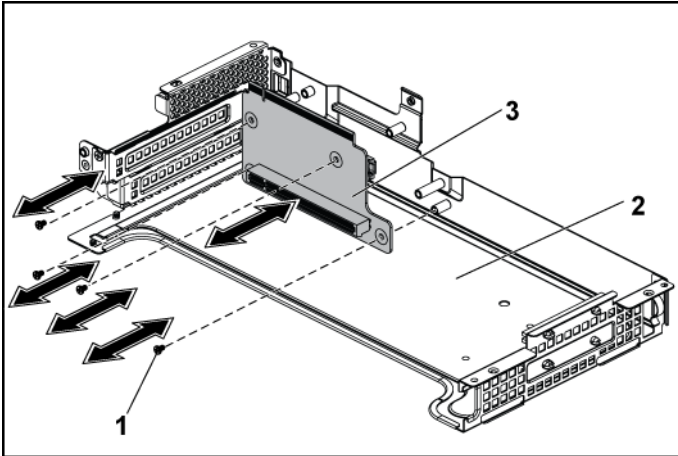

- | | | | |
|---|---------------|---|------------------------|
| 1 | screw (4) | 2 | expansion-card bracket |
| 3 | 2U riser card | | |

Installing the Riser card for 2U Node



CAUTION: Many repairs may only be done by a certified service technician. You should only perform troubleshooting and simple repairs as authorized in your product documentation, or as directed by the online or telephone service and support team. Damage due to servicing that is not authorized by Dell is not covered by your warranty. Read and follow the safety instructions that came with the product.

- 2 Place the 2U riser card into the expansion-card bracket. See Figure 3-39.
- 3 Replace the four screws securing the 2U riser card to the expansion-card bracket. See Figure 3-39.
- 4 Place the 1.5U riser card into the expansion-card bracket. See Figure 3-38.
- 5 Replace the two screws securing the 1.5U riser card to the expansion-card bracket. See Figure 3-38.
- 6 Install the expansion card. See “Installing the Expansion Card for 2U Node” on page 162.
- 7 Replace the system-board assembly. See “Installing a System-Board Assembly” on page 143.

Cable Routing for Riser Card (2U Node)

- 1 Connect the USB cable to the 1U riser card, and connect the other end of the cable to the corresponding connectors on the system board. See Figure 3-40.

Figure 3-40. Cable Routing for 2U Riser Card USB Cable

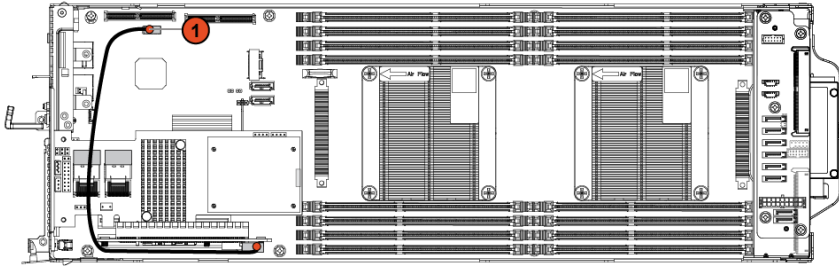

Item	Cable	From (Riser Card)	To (System Board)
1	USB cable	USB connector	internal USB connector

Optional Mezzanine Cards

Removing the LSI 2008 SAS Mezzanine Card



NOTE: The LSI 2008 SAS mezzanine card is seated in PCI-E Gen3 x8 mezzanine slot 3 on the system board, which is not active in 1-processor configuration. See “System Board Connectors” on page 294 for the location.



CAUTION: Many repairs may only be done by a certified service technician. You should only perform troubleshooting and simple repairs as authorized in your product documentation, or as directed by the online or telephone service and support team. Damage due to servicing that is not authorized by Dell is not covered by your warranty. Read and follow the safety instructions that came with the product.

- 1 Remove the system-board assembly. See “Removing a System-Board Assembly” on page 142.
- 2 Disconnect all the cables from the LSI 2008 SAS mezzanine card.
- 3 Remove the three screws that secure the LSI 2008 SAS mezzanine card. See Figure 3-41.
- 4 Lift the LSI 2008 SAS mezzanine card out of the system-board assembly. See Figure 3-41.

Figure 3-41. Removing and Installing the LSI 2008 SAS Mezzanine Card

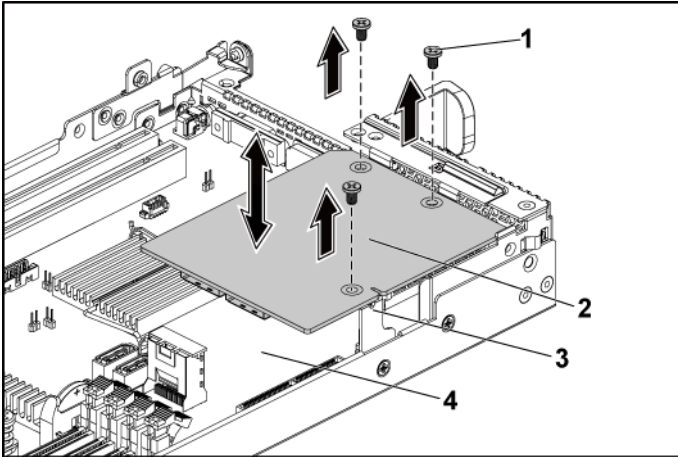

- | | | | |
|---|------------------|---|-----------------------------|
| 1 | screw (3) | 2 | LSI 2008 SAS mezzanine card |
| 3 | card bridge card | 4 | system-board assembly |

Installing the LSI 2008 SAS Mezzanine Card



CAUTION: Many repairs may only be done by a certified service technician. You should only perform troubleshooting and simple repairs as authorized in your product documentation, or as directed by the online or telephone service and support team. Damage due to servicing that is not authorized by Dell is not covered by your warranty. Read and follow the safety instructions that came with the product.

- 1 Place the LSI 2008 SAS mezzanine card on the system-board assembly. See Figure 3-41 and Figure 5-11.
- 2 Replace the three screws that secure the LSI 2008 SAS mezzanine card. See Figure 3-41.
- 3 Reconnect all the cables to the LSI 2008 SAS mezzanine card.
- 4 Replace the system-board assembly. See “Installing a System-Board Assembly” on page 143.

Cable Routing for LSI 2008 SAS Mezzanine Card (1U Node)

- 1 Connect the mini-SAS&SGPIO cable to the LSI 2008 SAS Mezzanine card, and connect the other end of the cable to the corresponding connectors on the system board. See Figure 3-42.
- 2 Connect the mini-SAS cable to the LSI 2008 SAS Mezzanine card, and connect the other end of the cable to the corresponding connector on the system board. See Figure 3-42.

Figure 3-42. Cable Routing for LSI 2008 SAS Mezzanine Card (1U Node)

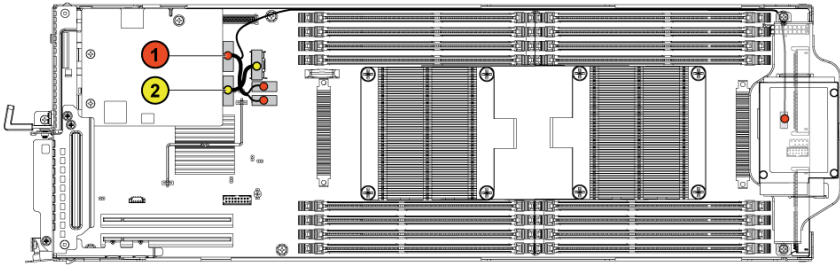

Item	Cable	From (LSI 2008 SAS Mezzanine Card)	To (System Board)
1	Mini-SAS /SGPIO cable	Mini-SAS connector 4~7 (J4)	Onboard SATAII connectors 4&5 and SGPIO 2
2	Mini-SAS cable	Mini-SAS connector 0~3 (J3)	Mini-SAS connector 0

Cable Routing for LSI 2008 SAS Mezzanine Card (2U Node)

- 1 Connect the mini-SAS cable to the LSI 2008 SAS mezzanine card, and connect the other end of the cable to the corresponding connector on the system board. See Figure 3-43.
- 2 Connect the mini-SAS&SGPIO cable to the LSI 2008 SAS mezzanine card, and connect the other end of the cable to the corresponding connectors on the interposer extender. See Figure 3-43.
- 3 Connect the power cable to the interposer extender for 2U node, and connect the other end of the cable to the corresponding connector on the system board. See Figure 3-43.

Figure 3-43. Cable Routing for LSI 2008 SAS Mezzanine Card (2U Node)

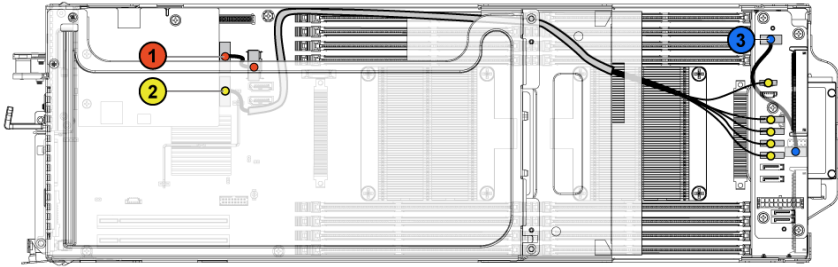

Item	Cable	From (LSI 2008 SAS Mezzanine Card)	To (System Board and Hard Drive to Backplane SATAII Connectors)
1	Mini-SAS cable	Mini-SAS connector 4~7 (J4)	Mini-SAS connector 0 on the system board
2	Mini-SAS /SGPIO cable	Mini-SAS connector 0~3 (J3)	SATAII connectors 0~3 and SGPIO 1 connector on the interposer extender for 2U node
3	Power cable	Control connector (J3) on the interposer extender for 2U node	Front panel connector 1 on the system board

- 4 Press down on the cables, and ensure the cables are routed lower than the height of the expansion card assembly for the 2U node.

Figure 3-44. Cable Routing Down for LSI 2008 SAS Mezzanine Card (2U Node)

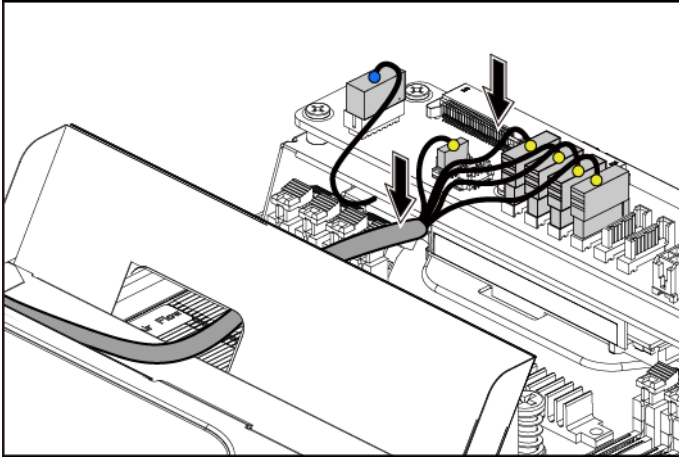

When securing the cable tie, make the cable tie go through the second air hole (from the bottom to the top) and then tighten it to encircle one of the mini-SAS cables. Ensure the other mini-SAS cable is held by the cable-tie clip.

Figure 3-45. Cable Tie for 2U Node

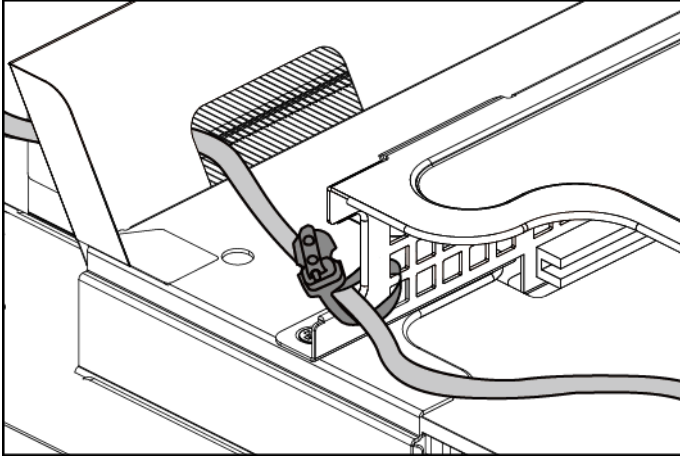

Removing the 1GbE Mezzanine Card



NOTE: The 1GbE mezzanine card is seated in PCI-E Gen3 x8 mezzanine slot 3 on the system board, which is not active in 1-processor configuration. See “System Board Connectors” on page 294 for the location.



CAUTION: Many repairs may only be done by a certified service technician. You should only perform troubleshooting and simple repairs as authorized in your product documentation, or as directed by the online or telephone service and support team. Damage due to servicing that is not authorized by Dell is not covered by your warranty. Read and follow the safety instructions that came with the product.

- 1 Remove the system-board assembly. See “Removing a System-Board Assembly” on page 142.
- 2 Disconnect all the cables from the 1GbE mezzanine card.
- 3 Remove the screws that secure the expansion-card bracket. See Figure 3-46 for 1U node. See Figure 3-17 for 2U node.
- 4 Lift the expansion-card bracket out of the system-board assembly. See Figure 3-46 for 1U node. See Figure 3-17 for 2U node.

Figure 3-46. Removing and Installing the Expansion-Card Bracket

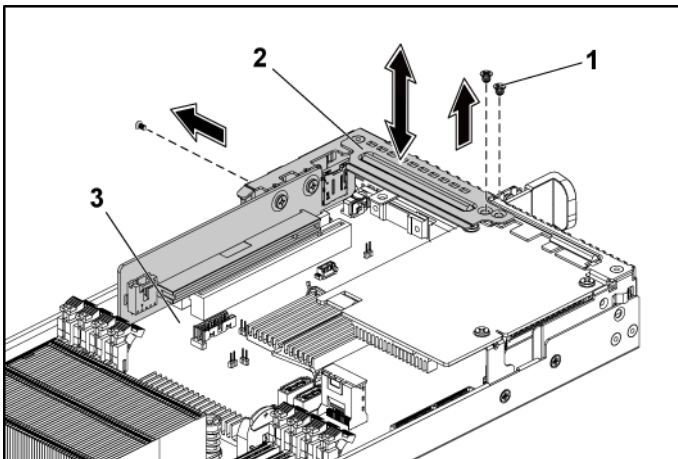

- 1 screw (3)
- 2 expansion-card bracket
- 3 system-board assembly

- 5 Remove the screws that secure the 1GbE mezzanine card assembly. See Figure 3-47.
- 6 Lift the 1GbE mezzanine card assembly away from the card bridge board on the system board. See Figure 3-47.

Figure 3-47. Removing and Installing the 1GbE mezzanine card assembly

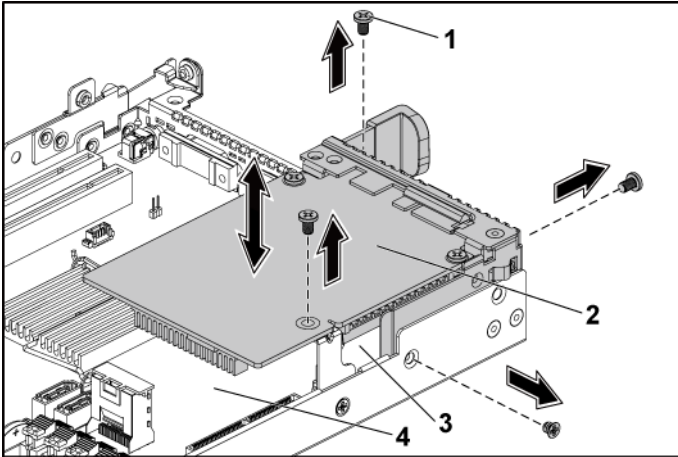

- | | | | |
|---|-------------------|---|------------------------------|
| 1 | screw (4) | 2 | 1GbE mezzanine card assembly |
| 3 | card bridge board | 4 | system-board assembly |

- 7 Remove the two screws that secure the 1GbE mezzanine card to the bracket. See Figure 3-48.
- 8 Remove the 1GbE mezzanine card from the bracket. See Figure 3-48.

Figure 3-48. Removing and Installing the 1GbE Mezzanine Card

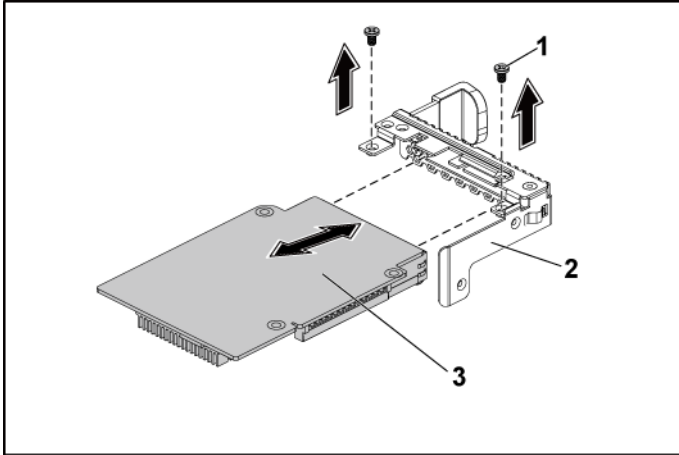

- | | | | |
|---|---------------------|---|------------------------|
| 1 | screw (2) | 2 | mezzanine card bracket |
| 3 | 1GbE mezzanine card | | |

Installing the 1GbE Mezzanine Card



CAUTION: Many repairs may only be done by a certified service technician. You should only perform troubleshooting and simple repairs as authorized in your product documentation, or as directed by the online or telephone service and support team. Damage due to servicing that is not authorized by Dell is not covered by your warranty. Read and follow the safety instructions that came with the product.

- 1 Attach the 1GbE mezzanine card to the bracket by aligning the four ports to the corresponding port slots on the bracket. See Figure 3-48.
- 2 Install the two screws to secure the 1GbE mezzanine card to the bracket. See Figure 3-48.
- 3 Install the 1GbE mezzanine card assembly to the card bridge board on the system-board assembly. See Figure 3-47.
- 4 Install the four screws to secure the 1GbE mezzanine card assembly to

- the system-board assembly. See Figure 3-47.
- 5 Place the expansion-card bracket into the system-board assembly. See Figure 3-46 for 1U node. See Figure 3-17 for 2U node.
 - 6 Replace the screws that secure the expansion-card bracket.
 - 7 Reconnect all the cables to the 1GbE mezzanine card.
 - 8 Replace the system-board assembly. See "Installing a System-Board Assembly" on page 143.

Removing the 10GbE Mezzanine Card



NOTE: The 10GbE mezzanine card is seated in PCI-E Gen3 x8 mezzanine slot 3 on the system board, which is not active in 1-processor configuration. See "System Board Connectors" on page 294 for the location.



CAUTION: Many repairs may only be done by a certified service technician. You should only perform troubleshooting and simple repairs as authorized in your product documentation, or as directed by the online or telephone service and support team. Damage due to servicing that is not authorized by Dell is not covered by your warranty. Read and follow the safety instructions that came with the product.

- 1 Remove the system-board assembly. See "Removing a System-Board Assembly" on page 142.
- 2 Disconnect all the cables from the 10GbE mezzanine card.

- 3 Remove the screws that secure the expansion-card bracket. See Figure 3-49 for 1U node. See Figure 3-17 for 2U node.
- 4 Lift the expansion-card bracket out of the system-board assembly. See Figure 3-49 for 1U node. See Figure 3-17 for 2U node.

Figure 3-49. Removing and Installing the Expansion-Card Bracket

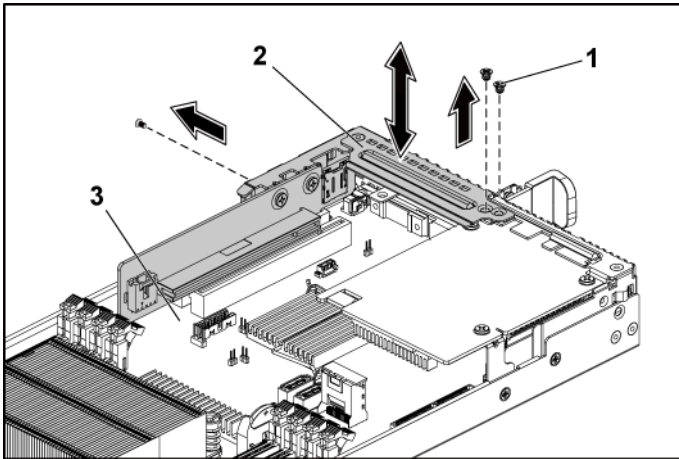

- | | | | |
|---|-----------------------|---|------------------------|
| 1 | screw (3) | 2 | expansion-card bracket |
| 3 | system-board assembly | | |

- 5 Remove the screws that secure the 10GbE mezzanine card assembly. See Figure 3-50.
- 6 Lift the 10GbE mezzanine card assembly away from the card bridge board on the system board. See Figure 3-50.

Figure 3-50. Removing and Installing the 10GbE mezzanine card assembly

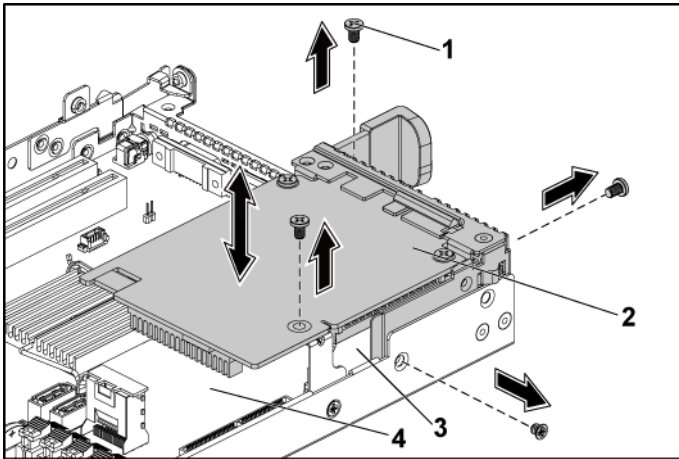

- | | | | |
|---|-------------------|---|-------------------------------|
| 1 | screw (4) | 2 | 10GbE mezzanine card assembly |
| 3 | card bridge board | 4 | system-board assembly |

- 7 Remove the two screws that secure the 10GbE mezzanine card to the bracket. See Figure 3-51.
- 8 Remove the 10GbE mezzanine card from the bracket. See Figure 3-51.

Figure 3-51. Removing and Installing the 10GbE Mezzanine Card

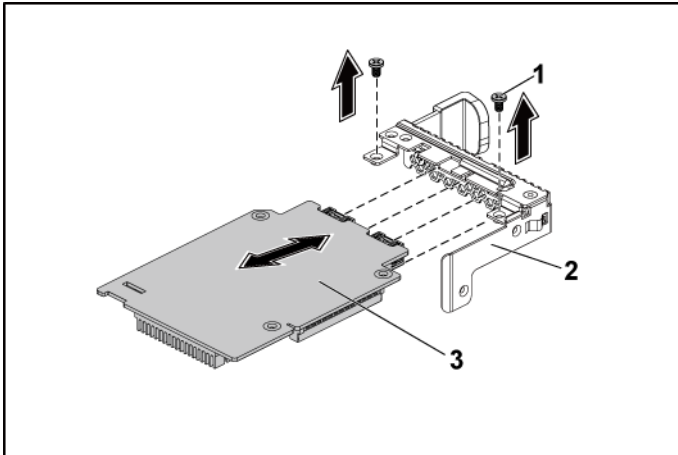

- | | | | |
|---|----------------------|---|------------------------|
| 1 | screw (2) | 2 | mezzanine card bracket |
| 3 | 10GbE mezzanine card | | |

Installing the 10GbE Mezzanine Card



CAUTION: Many repairs may only be done by a certified service technician. You should only perform troubleshooting and simple repairs as authorized in your product documentation, or as directed by the online or telephone service and support team. Damage due to servicing that is not authorized by Dell is not covered by your warranty. Read and follow the safety instructions that came with the product.

- 1 Attach the 10GbE mezzanine card to the bracket by aligning the four ports to the corresponding port slots on the bracket. See Figure 3-51.
- 2 Install the screws to secure the 10GbE mezzanine card to the bracket. See Figure 3-51.
- 3 Install the 10GbE mezzanine card assembly to the card bridge board on the system-board assembly. See Figure 3-50.

- 4 Install the screws to secure the 10GbE mezzanine card assembly to the system-board assembly. See Figure 3-50.
- 5 Place the expansion-card bracket into the system-board assembly. See Figure 3-49 for 1U node. See Figure 3-17 for 2U node.
- 6 Replace the screws that secure the expansion-card bracket.
- 7 Reconnect all the cables to the 10GbE mezzanine card.
- 8 Replace the system-board assembly. See "Installing a System-Board Assembly" on page 143.

Mezzanine-Card Bridge Board

Removing the Mezzanine-Card Bridge Board



CAUTION: Many repairs may only be done by a certified service technician. You should only perform troubleshooting and simple repairs as authorized in your product documentation, or as directed by the online or telephone service and support team. Damage due to servicing that is not authorized by Dell is not covered by your warranty. Read and follow the safety instructions that came with the product.

- 1 It is recommended to turn off the system, including any attached peripherals, and disconnect the system from its electrical outlet.
- 2 Remove the system-board assembly. See "Removing a System-Board Assembly" on page 142.
- 3 Remove the mezzanine card. See "Removing the LSI 2008 SAS Mezzanine Card" on page 193, "
- 4 Pull the mezzanine-card bridge board away from the mezzanine slot on the system board. See Figure 3-52.

Figure 3-52. Removing and Installing the Mezzanine-Card Bridge Board

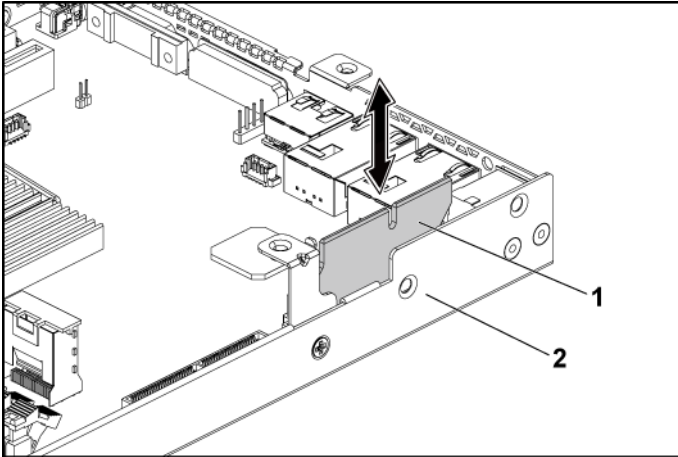

1 card bridge board

2 system-board assembly

Installing the Mezzanine-Card Bridge Board



CAUTION: Many repairs may only be done by a certified service technician. You should only perform troubleshooting and simple repairs as authorized in your product documentation, or as directed by the online or telephone service and support team. Damage due to servicing that is not authorized by Dell is not covered by your warranty. Read and follow the safety instructions that came with the product.

- 1 Install the mezzanine-card bridge board into the mezzanine slot on the system board. See Figure 3-52.
- 2 Install the mezzanine card. See "Installing the LSI 2008 SAS Mezzanine Card" on page 194, "Installing the 1GbE Mezzanine Card" on page 201 and "Installing the 10GbE Mezzanine Card" on page 205.
- 3 Install the system-board assembly. See "Installing a System-Board Assembly" on page 143.
- 4 Reconnect the system to its electrical outlet and turn on the system, including any attached peripherals.

System Memory

Each system board has sixteen DDR3 memory module slots for the installation of up to sixteen unbuffered or registered DDR3-1333MHz (1600MHz @2 memory modules per channel) memory modules to support processor 1 and processor 2. See “System Board Connectors” on page 294 for the location of the memory modules.

Memory Slot Features

- Support 8 channels, 16 UDIMMs/RDIMMs of DDR3
- Speed up to 1600MT/s
- Max. capacity: 512GB with 32GB RDIMM, LRDIMM
- Support DDR3/DDR3L
- Support ECC

Supported Memory Module Configuration

For the sequence of the sixteen memory-module slots, see Figure 3-53. The system requires at least one memory module installed on processor 1’s DIMM slot 1 in order to be booted up. When you insert the memory module(s), always start with CHA_A1. The optimized memory module installation sequence is 1/2/3/4/5/6/7/8.

See Table 3-2 and Table 3-3 for possible memory configurations.

Figure 3-53. DIMM Slot Locations

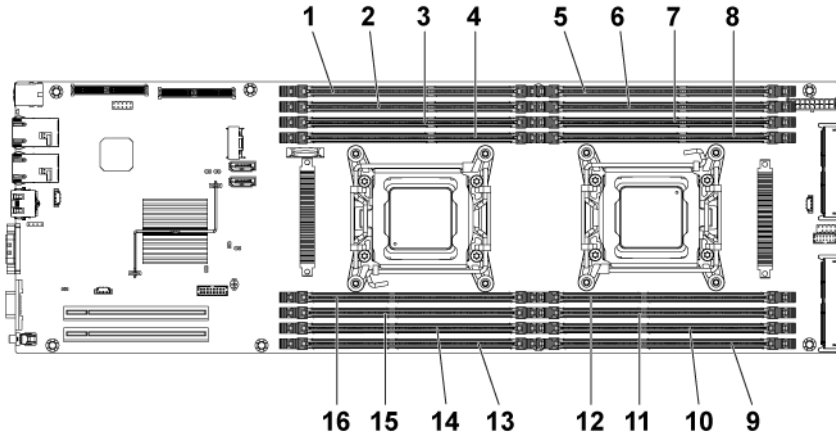

- | | | | |
|----|---------|----|---------|
| 1 | DIMM_A3 | 2 | DIMM_A7 |
| 3 | DIMM_A4 | 4 | DIMM_A8 |
| 5 | DIMM_B1 | 6 | DIMM_B5 |
| 7 | DIMM_B2 | 8 | DIMM_B6 |
| 9 | DIMM_B3 | 10 | DIMM_B7 |
| 11 | DIMM_B4 | 12 | DIMM_B8 |
| 13 | DIMM_A1 | 14 | DIMM_A5 |
| 15 | DIMM_A2 | 16 | DIMM_A6 |

Table 3-2. Memory Module Configurations for Single Processor

Memory Module	Processor 1							
	CHA		CHB		CHC		CHD	
	A1	A5	A2	A6	A3	A7	A4	A8
1	√	—	—	—	—	—	—	—
2	√	—	√	—	—	—	—	—
3	√	—	√	—	√	—	—	—
4	√	—	√	—	√	—	√	—
6	√	√	√	√	√	—	√	—
8	√	√	√	√	√	√	√	√

Table 3-3. Memory Module Configurations for Dual Processors

Memory Module	Processor 1							
	CHA		CHB		CHC		CHD	
	A1	A5	A2	A6	A3	A7	A4	A8
2	√	–	–	–	–	–	–	–
6	√	–	√	–	√	–	–	–
8	√	–	√	–	√	–	√	–
12	√	√	√	√	√	–	√	–
16	√	√	√	√	√	√	√	√

Memory Module	Processor 2							
	CHA		CHB		CHC		CHD	
	B1	B5	B2	B6	B3	B7	B4	B8
2	√	–	–	–	–	–	–	–
6	√	–	√	–	√	–	–	–
8	√	–	√	–	√	–	√	–
12	√	√	√	√	√	–	√	–
16	√	√	√	√	√	√	√	√

Removing the Memory Modules



WARNING: The memory modules are hot to the touch for some time after the system has been powered down. Allow time for the memory modules to cool before handling them. Handle the memory modules by the card edges and avoid touching the components on the memory module.



CAUTION: Many repairs may only be done by a certified service technician. You should only perform troubleshooting and simple repairs as authorized in your product documentation, or as directed by the online or telephone service and support team. Damage due to servicing that is not authorized by Dell is not covered by your warranty. Read and follow the safety instructions that came with the product.

- 1 Remove the system-board assembly. See “Removing a System-Board Assembly” on page 142.
- 2 Remove the air baffle for 1U node. See “Removing the Air Baffle ” on page 144; Remove the expansion card assembly for 2U node. See

“Removing the Expansion Card for 2U Node” on page 158.

- 3 When removing the memory module from the system equipped with the RAID battery assembly, remove the RAID battery assembly first. See “Removing the LSI 9265-8i raid battery Assembly” on page 180. Locate the memory module sockets. See Figure 3-54.

△ CAUTION: Handle each memory module only on either card edge, making sure not to touch the middle of the memory module. To avoid damaging components on the memory module, remove only one memory module at a time.

- 4 Simultaneously press down and out on the ejectors at both ends of the memory module socket until the memory module is released from the socket. See Figure 3-54.
- 5 Lift the memory module out of the socket by contact only at the ends of the module. See Figure 3-54.

Figure 3-54. Removing a Memory Module

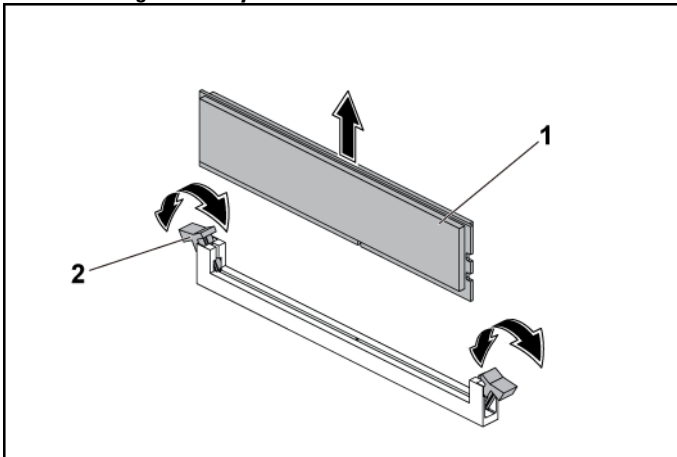

1 memory module

2 memory module socket ejector
(2)

Installing the Memory Modules



WARNING: The memory modules are hot to the touch for some time after the system has been powered down. Allow time for the memory modules to cool before handling them. Handle the memory modules by the card edges and avoid touching the components on the memory module.



CAUTION: Many repairs may only be done by a certified service technician. You should only perform troubleshooting and simple repairs as authorized in your product documentation, or as directed by the online or telephone service and support team. Damage due to servicing that is not authorized by Dell is not covered by your warranty. Read and follow the safety instructions that came with the product.

- 1 Press down and out on the ejectors on each end of the memory module socket. See Figure 3-55.
- 2 Align the memory module correctly with the alignment key of the memory module socket. See Figure 3-55.
- 3 Press down firmly on the memory module with your thumbs until the module snaps into place. See Figure 3-55.



CAUTION: Even pressure during insertion must be applied at both ends of the module simultaneously to prevent damage to the socket. No pressure should be applied to the center of the module.

Complete the latching of the module into the socket by applying inward pressure to the socket ejectors to assure that the ejectors are in a locked position. When the memory module is properly seated in the socket, the ejectors on the memory module socket align with the ejectors on other identical sockets that have memory modules installed.

Figure 3-55. Installing a Memory Module

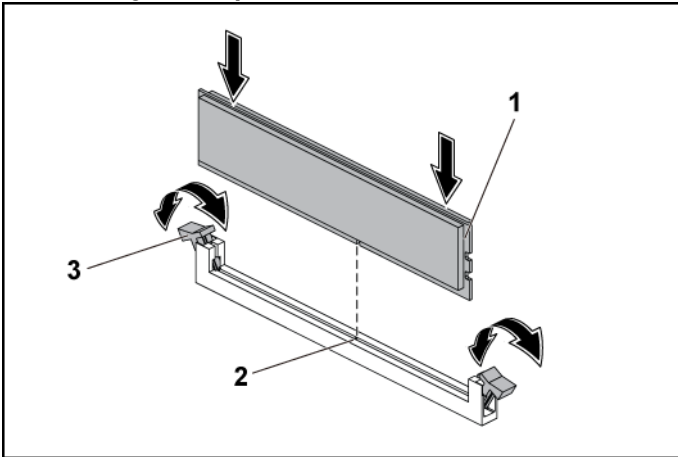

- 1 memory module
- 2 alignment key
- 3 memory module socket ejector (2)
- 4 Replace the air baffle for 1U node. See “Installing the Air Baffle ” on page 145; Replace the expansion card assembly for 2U node. See “Installing the Expansion Card for 2U Node” on page 162.
- 5 Replace the system-board assembly. See “Installing a System-Board Assembly” on page 143.

System Battery

Replacing the System Battery



WARNING: There is a danger of a new battery exploding if it is incorrectly installed. Replace the battery only with the same or equivalent type recommended by the manufacturer. See your safety information for additional information.



CAUTION: Many repairs may only be done by a certified service technician. You should only perform troubleshooting and simple repairs as authorized in your product documentation, or as directed by the online or telephone service and support team. Damage due to servicing that is not authorized by Dell is not covered by your warranty. Read and follow the safety instructions that came with the product.

- 1 Remove the system-board assembly. See “Removing a System-Board Assembly” on page 142.
- 2 Remove the expansion card assembly. See “Removing the Expansion Card for 1U Node” on page 154. Locate the battery location. See “System Board Connectors” on page 294.



CAUTION: To avoid damage to the battery connector, you must firmly support the connector while installing or removing a battery.

- 3 Gently lift the battery out of the connector. See Figure 3-56.
- 4 Hold the new battery with the “+” facing the positive side of battery connector. See Figure 3-56.
- 5 Insert the battery into the battery holder until it is seated in place. See Figure 3-56.

Figure 3-56. Replacing the System Battery

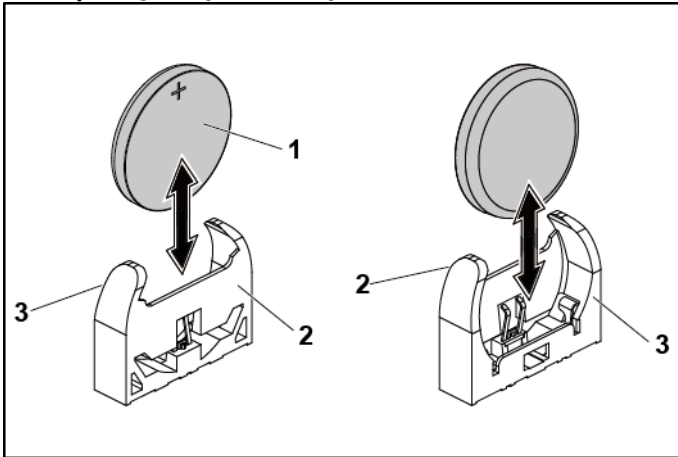

1 system battery

2 positive side of battery connector

3 negative side of battery connector

- 6 Replace the system-board assembly. See “Installing a System-Board Assembly” on page 143.
- 7 Enter the System Setup program to confirm that the battery is operating properly. See “Using the System Setup Program” on page 58.
- 8 Enter the correct time and date in the System Setup program’s **Time** and **Date** fields.
- 9 Exit the System Setup program.

System Board

Removing a System Board



CAUTION: Many repairs may only be done by a certified service technician. You should only perform troubleshooting and simple repairs as authorized in your product documentation, or as directed by the online or telephone service and support team. Damage due to servicing that is not authorized by Dell is not covered by your warranty. Read and follow the safety instructions that came with the product.

- 1 Remove the system-board assembly. See “Removing a System-Board Assembly” on page 142.
- 2 Remove the air baffle for 1U node. See “Removing the Air Baffle ” on page 144.
- 3 Remove the expansion-card assembly. See “Removing the Expansion Card” on page 154.
- 4 Remove the heat sink. See “Removing the Heat Sink” on page 145.
- 5 Remove the memory modules. See “Removing the Memory Modules” on page 210.
- 6 If installed, remove the SAS mezzanine card or 1GbE mezzanine card or 10GbE mezzanine card. See “Removing the LSI 2008 SAS Mezzanine Card” on page 193, “Removing the 1GbE Mezzanine Card” on page 197 and “Removing the 10GbE Mezzanine Card” on page 202.
- 7 Disconnect all the cables from the system board.
- 8 Remove the eight screws and then slide the system board. See Figure 3-57



CAUTION: Do not lift the system board by grasping a memory module, processor, or other components.

- 9 Grasp the system board by the edges and lift the system board away from the system-board assembly. See Figure 3-57.

Figure 3-57. Removing and Installing the System Board

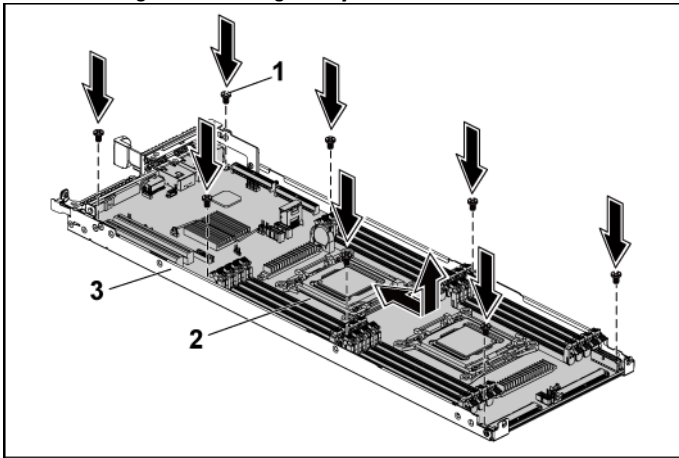

- 1 screw (8)
- 2 system board
- 3 system-board assembly

Installing a System Board

- 1 Unpack the new system board.
- 2 Holding the system board by the edges, slide the system board into the system-board assembly.
- 3 Replace the eight screws to secure the system board to the system-board assembly.
- 4 Transfer the processors to the new system board. See “Removing a Processor” on page 147 and “Installing a Processor” on page 149.
- 5 Remove the memory modules and transfer them to the same locations on the new board. See “Removing the Memory Modules” on page 210 and “Installing the Memory Modules” on page 212.
- 6 Replace the heat sinks. See “Installing the Heat Sink” on page 146.
- 7 Install the expansion-card assembly. See “Installing the Expansion Card” on page 157.

- 8 If applicable, install the SAS mezzanine card or 1GbE mezzanine card or 10GbE mezzanine card. See “Installing the LSI 2008 SAS Mezzanine Card” on page 194, “Installing the 1GbE Mezzanine Card” on page 201 and “Installing the 10GbE Mezzanine Card” on page 205.
- 9 Connect all the cables to the system board.
- 10 Replace the air baffle for 1U node. See “Installing the Air Baffle ”on page 145.
- 11 Replace the system-board assembly. See “Installing a System-Board Assembly” on page 143.

Opening and Closing the System



WARNING: Whenever you need to lift the system, get others to assist you. To avoid injury, do not attempt to lift the system by yourself.



CAUTION: This system must be operated with the system cover installed to ensure proper cooling.



CAUTION: Many repairs may only be done by a certified service technician. You should only perform troubleshooting and simple repairs as authorized in your product documentation, or as directed by the online or telephone service and support team. Damage due to servicing that is not authorized by Dell is not covered by your warranty. Read and follow the safety instructions that came with the product.

Opening the System

- 1 It is recommended to turn off the system, including any attached peripherals, and disconnect the system from the electrical outlet.
- 2 Remove the securing screw from the system cover. See Figure 3-58.
- 3 Press the cover release latch lock. See Figure 3-58.
- 4 Grasp cover on both the sides with your palm on the traction pad, slide out and lift the cover away from the system. See Figure 3-58.

Figure 3-58. Opening and Closing the System

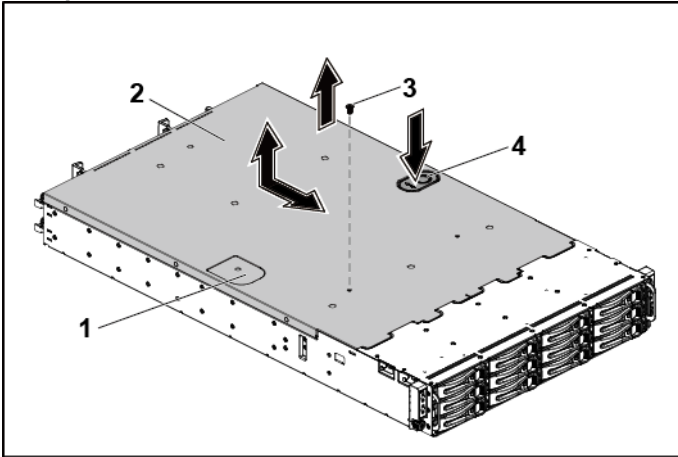

- | | | | |
|---|----------------|---|--------------------------|
| 1 | traction pad | 2 | system cover |
| 3 | securing screw | 4 | cover release latch lock |

Closing the System

- 1 Place the cover on the chassis and slide it to the front of the chassis until it snaps into place. See Figure 3-58.
- 2 Secure the cover with the securing screw. See Figure 3-58.

Cooling Fans

Removing a Cooling Fan



WARNING: Do not attempt to operate the system without the cooling fans.



WARNING: The cooling fan can continue to spin for some time after the system has been powered down. Allow time for the fan to stop spinning before removing it from the system.



CAUTION: Many repairs may only be done by a certified service technician. You should only perform troubleshooting and simple repairs as authorized in your product documentation, or as directed by the online or telephone service and support team. Damage due to servicing that is not authorized by Dell is not covered by your warranty. Read and follow the safety instructions that came with the product.

- 1 It is recommended to turn off the system, including any attached peripherals, and disconnect the system from its electrical outlet.
- 2 Open the system. See “Opening the System” on page 218.
- 3 Disconnect the fan’s power cable from the power distribution board 1. Note the routing of the cable through the cable tie as you remove them from the system. You must route these cables properly when you replace them to prevent the cables from being pinched or crimped.

4 Directly lift the cooling-fan cage out of the chassis. See Figure 3-59.

Figure 3-59. Removing and Installing a Cooling Fan Cage

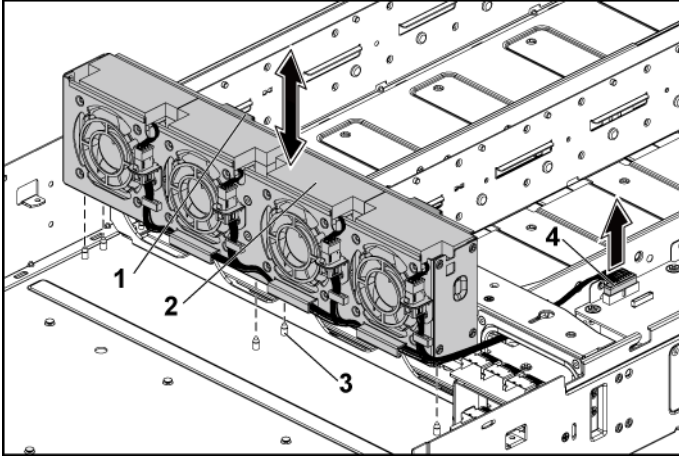

1 locking clips (2)

2 cooling-fan cage

3 locating pin (6)

4 power connector

- 5 Disconnect the fan cable from the fan connector on the cooling-fan cage. See Figure 3-60.
- 6 Lift the cooling fan with the sponge out of the cooling-fan cage. See Figure 3-60.

Figure 3-60. Removing and Installing a Cooling Fan

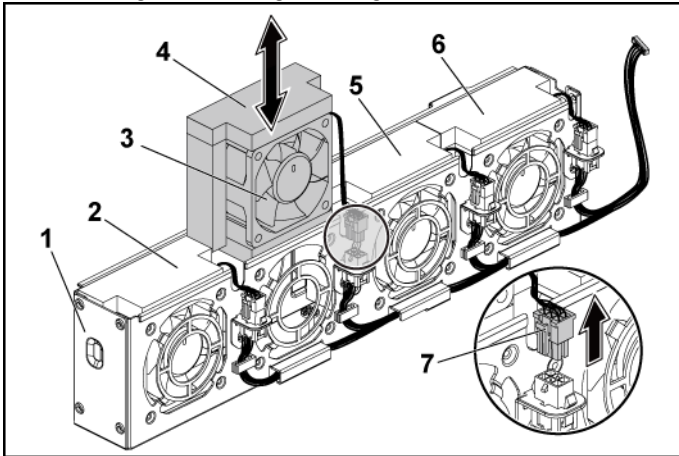

- | | | | |
|---|------------------|---|---------------|
| 1 | cooling-fan cage | 2 | cooling fan 1 |
| 3 | cooling fan 2 | 4 | sponge |
| 5 | cooling fan 3 | 6 | cooling fan 4 |

Installing a Cooling Fan



CAUTION: Many repairs may only be done by a certified service technician. You should only perform troubleshooting and simple repairs as authorized in your product documentation, or as directed by the online or telephone service and support team. Damage due to servicing that is not authorized by Dell is not covered by your warranty. Read and follow the safety instructions that came with the product.

- 1 Align the cooling fan with sponge and slide it in the cooling-fan cage until the cooling fan is firmly seated. See Figure 3-60.



NOTE: The fan blades should face the front panel of the system.

- 2 Connect the fan cable to the connector on the cooling-fan cage.
- 3 Align the cooling-fan cage with the locating pins on the chassis and place it into the chassis until it's firmly seated in place. See Figure 3-59.
- 4 Connect the fan's power cable to the connector on the power distribution board 1. See Figure 3-59.

You must route these cables properly through the ties to prevent them from being pinched or crimped.

- 5 Close the system. See “Closing the System” on page 219.
- 6 Reconnect the system to its electrical outlet and turn on the system, including any attached peripherals.

Power Distribution Boards

Removing a Power Distribution Board



CAUTION: Many repairs may only be done by a certified service technician. You should only perform troubleshooting and simple repairs as authorized in your product documentation, or as directed by the online or telephone service and support team. Damage due to servicing that is not authorized by Dell is not covered by your warranty. Read and follow the safety instructions that came with the product.



NOTE: This system has two power distribution boards. The procedure to remove and install both the power distribution boards is similar. To access the power distribution board 2 at the bottom, remove the power distribution board at the top.

- 1 It is recommended to turn off the system, including any attached peripherals, and disconnect the system from its electrical outlet.
- 2 Open the system. See “Opening the System” on page 218.
- 3 Remove the power supply. See “Removing and Installing a Power Supply” on page 139.

- 4 Disconnect all the cables from the first power distribution board. See Figure 3-66.
Note the routing of the cable on the chassis as you remove them from the system. You must route these cables properly when you replace them to prevent the cables from being pinched or crimped.
- 5 Remove the screw that secure the power cable cover to the power distribution board 1. See Figure 3-61.
- 6 Lift it up straightly from the locking hole on the power distribution board 1. Then, lift it completely out of the power distribution board 1. See Figure 3-61.

Figure 3-61. Removing and Installing the Power Cable Cover

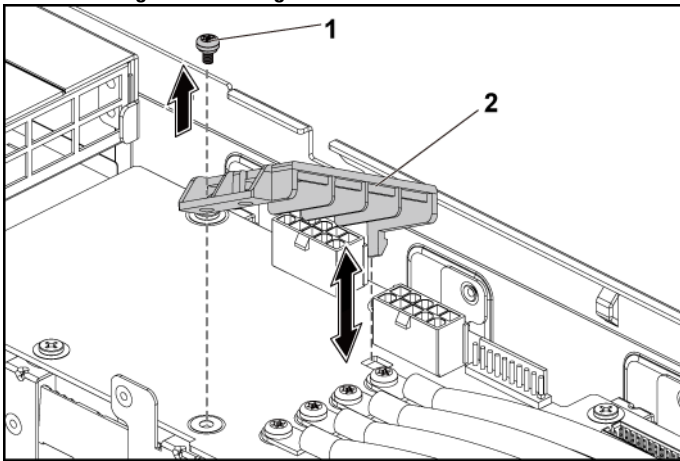

1 screw

2 power cable cover

- 7 Remove the four screws that secure the power cables to the power distribution board 1. See Figure 3-62.

Figure 3-62. Removing and Installing the Power Cables

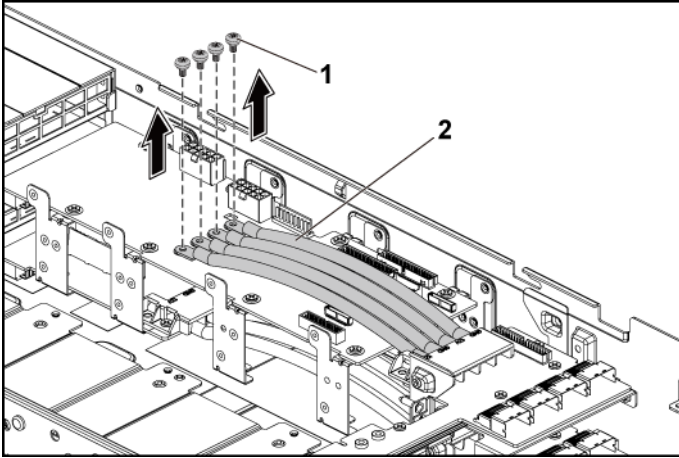

1 screw (4)

2 power cables (4)

- 8 Remove the screws securing the first power distribution board to the system. See Figure 3-63.
- 9 Lift the first power distribution board out of the system. See Figure 3-63.

Figure 3-63. Removing and Installing the Power Distribution Board 1

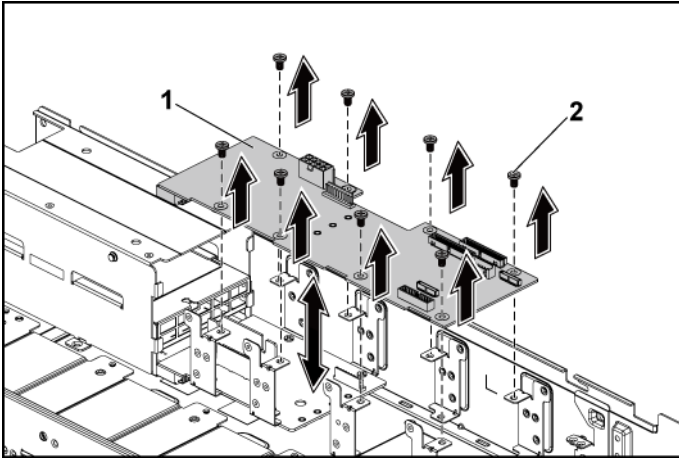

1 power distribution board 1

2 screw (8)

- 10 Lift the power distribution board connector from the system. See Figure 3-64.

Figure 3-64. Removing and Installing the Power Distribution Board Connector

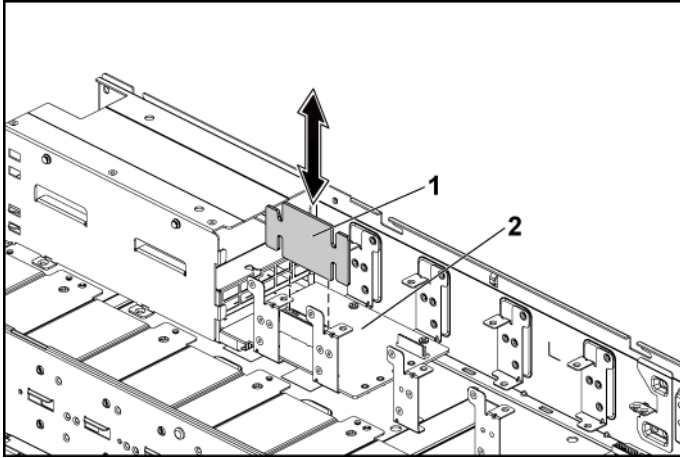

- 1 power distribution board connector 2 power distribution board 2

- 11 Disconnect all the cables from the power distribution board 2. See Figure 3-61.
- 12 Remove the power cable cover from the power distribution board 2. See Figure 3-61.
- 13 Remove the four power cables from the power distribution board 2. See Figure 3-62.

- 14 Remove the screws securing the power distribution board 2 to the system. See Figure 3-65.
- 15 Lift the power distribution board 2 out of the system. See Figure 3-65.



NOTE: To remove the power distribution board 2 that is below the first power distribution board, remove the power distribution board connector and angle the board before lifting.

Figure 3-65. Removing and Installing a Power Distribution Board 2

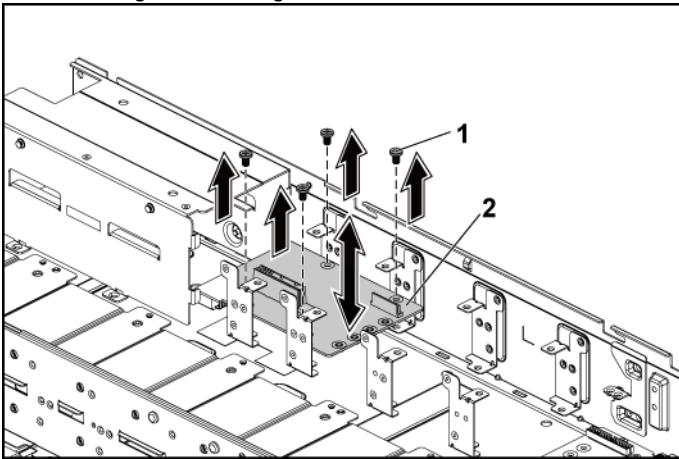

1 screw (4)

2 2nd power distribution board

Installing a Power Distribution Board



CAUTION: Many repairs may only be done by a certified service technician. You should only perform troubleshooting and simple repairs as authorized in your product documentation, or as directed by the online or telephone service and support team. Damage due to servicing that is not authorized by Dell is not covered by your warranty. Read and follow the safety instructions that came with the product.



CAUTION: If removed, you must replace the power distribution board 2 at the bottom and the power distribution board-connector before replacing the first power distribution board at the top.

- 1 If removed, first place the power distribution board 2 in the system. See Figure 3-65. Otherwise skip to step 5.



NOTE: To install the power distribution board 2 that is below the first power distribution board, angle the board during installation.

- 2 Replace the screws securing the power distribution board 2 to the system. See Figure 3-65.
- 3 Replace the power distribution board-connector. See Figure 3-64.
- 4 Connect all the cables to the power distribution board 2. See Figure 3-67.
You must route these cables properly through the tabs on the chassis to prevent them from being pinched or crimped.
- 5 Replace the first power distribution board to the system. See Figure 3-63.
- 6 Replace the screws securing the first power distribution board to the system. See Figure 3-63.
- 7 Connect all the cables to the first power distribution board. See Figure 3-66.
You must route these cables properly through the tabs on the chassis to prevent them from being pinched or crimped.
- 8 Replace the power supply. See “Installing a Power Supply” on page 140.
- 9 Close the system. See “Closing the System” on page 219.
- 10 Reconnect the system to its electrical outlet and turn on the system, including any attached peripherals.

Cable Routing for Power Distribution Board

Cable routings for power distribution board 1 (top) and power distribution board 2 (bottom) in the 1U node system and 2U node system are the same. The following figure shows an example using 1U node system.

Figure 3-66. Cable Routing-Power Distribution Board 1 (Top)

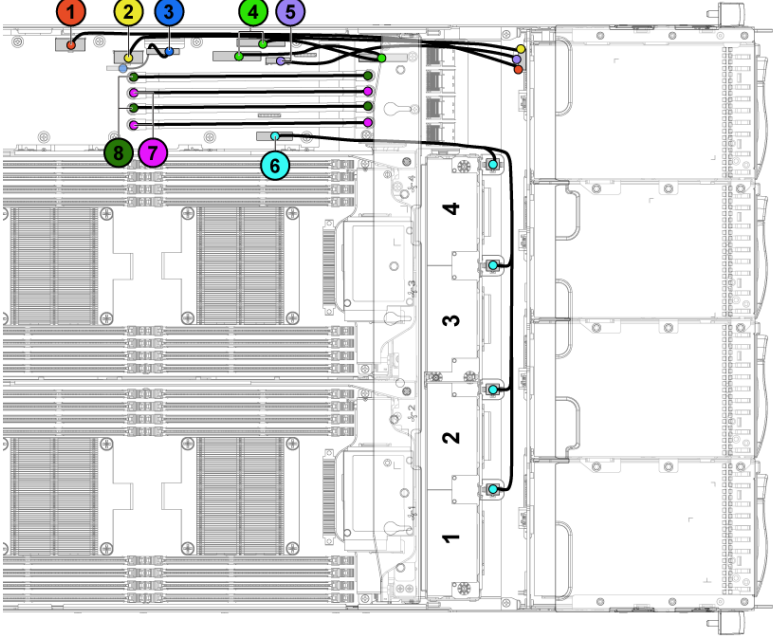

Item	Cable	From (Power Distribution Boards)	To
1	Hard-drive backplane power cable	Hard-drive backplane power connector (J84)	Backplane
2	Hard-drive backplane power cable	Hard-drive backplane power connector (J29)	Backplane
3	Power distribution board cable	Control connector (J31)	Power distribution board 2
4	I2C cables	System board control connectors (J5&J6)	Middle planes
5	Backplane control cable	Hard-drive backplane control connector (J17)	Backplane
6	System fan cable	System fan connector (J9)	System fans
7	12V power cables	Power distribution board 1/2	Middle planes
8	Ground power cables	Power distribution board 1/2	Middle planes

Figure 3-67. Cable Routing–Power Distribution Board 2 (Bottom)

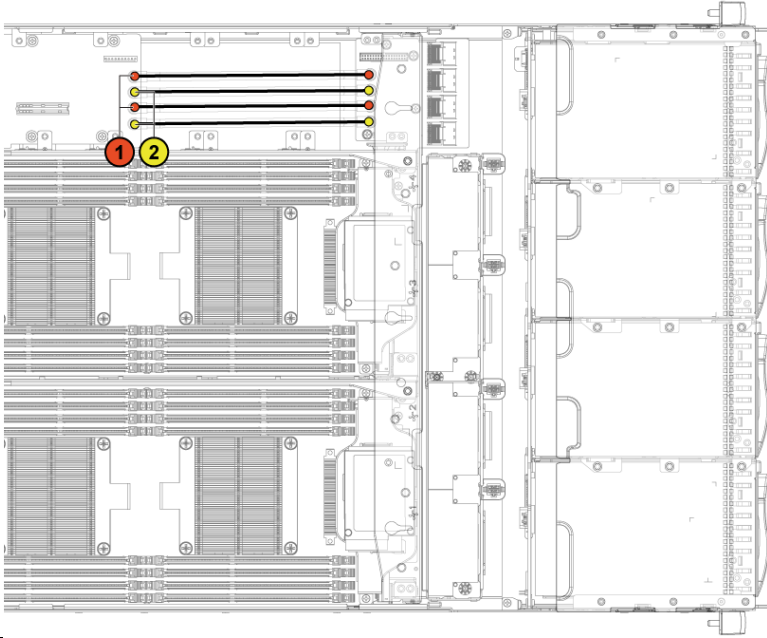

Item	Cable	From (Power Distribution Board 2)	To
1	Ground power cables	Power distribution board 1/2	Middle planes
2	12V power cables	Power distribution board 1/2	Middle planes

Middle Planes

Removing the Middle Planes



CAUTION: Many repairs may only be done by a certified service technician. You should only perform troubleshooting and simple repairs as authorized in your product documentation, or as directed by the online or telephone service and support team. Damage due to servicing that is not authorized by Dell is not covered by your warranty. Read and follow the safety instructions that came with the product.

- 1 It is recommended to turn off the system, including any attached peripherals, and disconnect the system from its electrical outlet.
- 2 Open the system. See “Opening the System” on page 218.
- 3 Remove the system-board assemblies. See “Removing a System-Board Assembly” on page 142.
- 4 Remove the cooling-fan cage. See “Removing a Cooling Fan” on page 220.

- 5 Remove the screws that secure the middle-wall bracket to the chassis. See Figure 3-68.
- 6 Lift the middle-wall bracket out of chassis. See Figure 3-68.

Figure 3-68. Removing and Installing the Middle-Wall Bracket

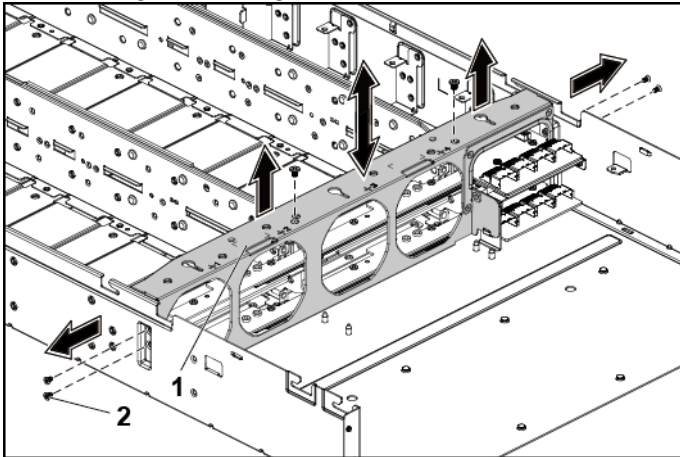

- 1 middle-wall bracket
- 2 screw (6)

- 7 Disconnect all the cables from the upper middle plane. Note the routing of the cable on the chassis as you remove them from the system. You must route these cables properly when you replace them to prevent the cables from being pinched or crimped.

- 8 Remove the screw that secures the power cable cover to the upper middle plane. See Figure 3-69.
- 9 Lift it up straightly from the locking hole on the upper middle plane. Then, lift it completely out of the upper middle plane. See Figure 3-69.

Figure 3-69. Removing and Installing the Power Cable Cover

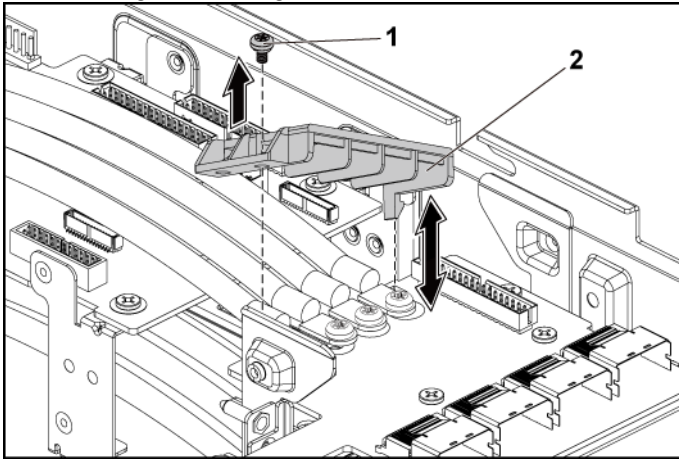

1 screw

2 power cable cover

10 Remove the four screws that secure the power cables to the upper middle plane. See Figure 3-70.

Figure 3-70. Removing and Installing the Power Cables

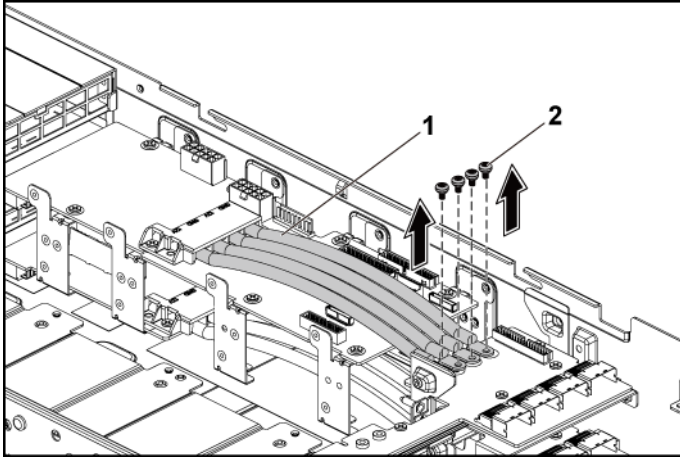

1 power cables (4)

2 screw (4)

- 11 Remove the screws that secure the upper middle plane to the middle plane holder. Figure 3-71.
- 12 Lift the upper middle plane out. See Figure 3-71.

Figure 3-71. Removing and Installing the Upper Middle Plane

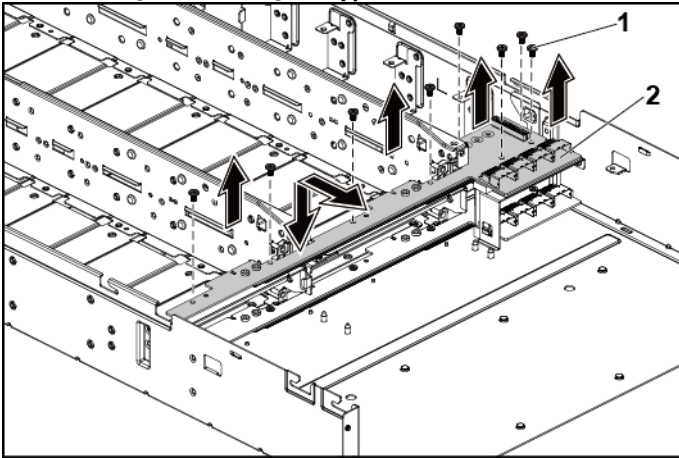

1 screw (8)

2 upper middle plane

- 13 Remove the screws that secure the mid-plane holder support to the chassis. See Figure 3-72.
- 14 Lift the mid-plane holder support out of the chassis. See Figure 3-72.

Figure 3-72. Removing and Installing the Mid-plane Holder Support

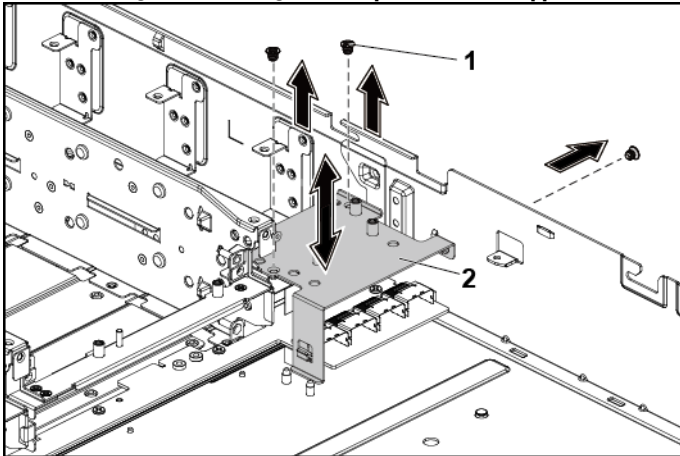

1 screw (3)

2 mid-plane holder support

- 15 Remove the screws that secure the mid-plane holder to the chassis.
Figure 3-73.
- 16 Lift the mid-plane holder out of the chassis. See Figure 3-73.

Figure 3-73. Removing and Installing the Mid-plane Holder

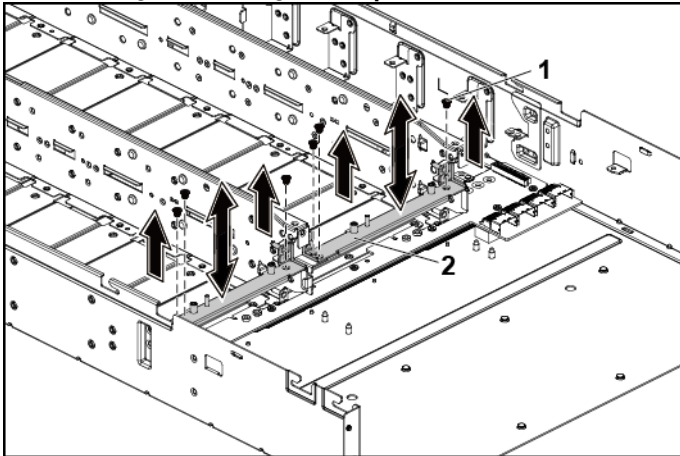

1 screw (6)

2 mid-plane holder

- 17 Disconnect all the cables from the lower middle plane.
Note the routing of the cable on the chassis as you remove them from the system. You must route these cables properly when you replace them to prevent the cables from being pinched or crimped.
- 18 Remove the power cable cover from the lower middle plane. See Figure 3-69.
- 19 Remove the four power cables from the lower middle plane. See Figure 3-70.

- 20 Remove the screws that secure the lower middle plane to the chassis.
Figure 3-74.
- 21 Lift the lower middle plane out of the chassis. See Figure 3-74.

Figure 3-74. Removing and Installing the Lower Middle Plane

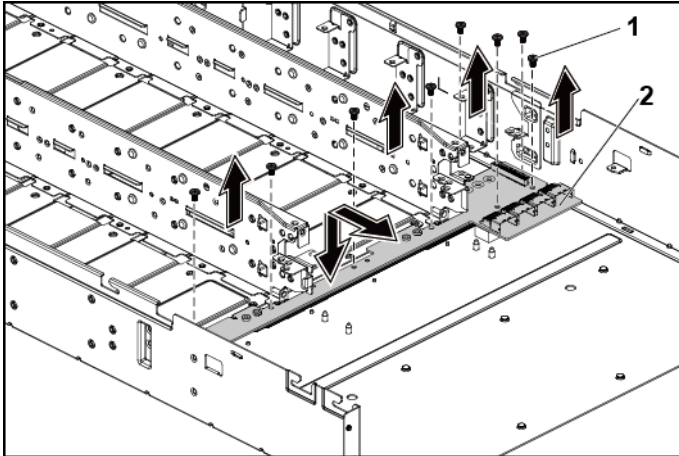

- | | | | |
|---|-----------|---|--------------------|
| 1 | screw (8) | 2 | lower middle plane |
|---|-----------|---|--------------------|

Installing the Middle Planes



CAUTION: Many repairs may only be done by a certified service technician. You should only perform troubleshooting and simple repairs as authorized in your product documentation, or as directed by the online or telephone service and support team. Damage due to servicing that is not authorized by Dell is not covered by your warranty. Read and follow the safety instructions that came with the product.

- 1 Place the lower middle plane into the chassis. See Figure 3-74.
- 2 Replace the screws that secure the lower middle plane to the chassis.
See Figure 3-74.
- 3 Connect all the cables to the lower middle plane.
You must route these cables properly on the chassis to prevent them from being pinched or crimped.

- 4 Secure the screws that secure the power cables to the lower middle plane.
- 5 Replace the power cable cover to the lower middle plane.
- 6 Place the middle plane holder into the chassis. See Figure 3-73.
- 7 Replace the screws that secure the middle plane holder to the chassis. See Figure 3-73.
- 8 Place the mid-plane holder support into the chassis. See Figure 3-72.
- 9 Replace the screws that secure the mid-plane holder support to the chassis. See Figure 3-72.
- 10 Place the upper middle plane on the mid-plane holder. See Figure 3-71.
- 11 Replace the screws that secure the middle plane to the middle plane holder. See Figure 3-71.
- 12 Connect all the cables to the upper middle plane.
You must route these cables properly on the chassis to prevent them from being pinched or crimped.
- 13 Secure the screws that secure the power cables to the upper middle plane.
- 14 Replace the power cable cover to the upper lower middle plane.
- 15 Place the middle-wall bracket into the chassis. See Figure 3-68.
- 16 Replace the screws that secure the middle-wall bracket to the chassis. See Figure 3-68.
- 17 Replace the cooling-fan cage. See Figure 3-59.
- 18 Replace the cooling fans. See “Installing a Cooling Fan” on page 222.
- 19 Replace the system-board assemblies. See “Installing a System-Board Assembly” on page 143.
- 20 Close the system, see “Closing the System” on page 219.
- 21 Reconnect the system to its electrical outlet and turn on the system, including any attached peripherals.

Cable Routing for Middle Plane to Direct Hard-Drive Backplane
Figure 3-75. Cable Routing—Top Middle Plane to Direct Backplane for 12 x3.5”
Hard-Drive Configuration

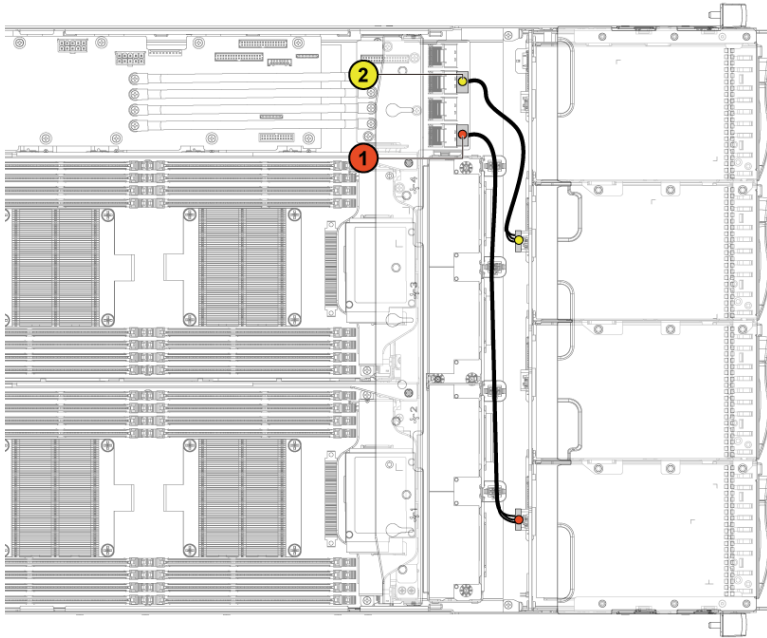

Item	Cable	From (Top Middle Plane)	To (Direct Backplane)
1	Hard-drive backplane cable	mini-SAS connector for system board 1 and 2 (hard drive 1,2,3 and 4) (J1)	SATA2 hard drive connectors 1,2, and 3 for system board 1 (from top to bottom)
2	Hard-drive backplane cable	mini-SAS connector for system board 3 and 4 (hard drive 1,2,3 and 4) (J3)	SATA2 hard drive connectors 1,2, and 3 for system board 3 (from top to bottom)

Figure 3-76. Cable Routing—Bottom Middle Plane to Direct Backplane for 12 x3.5" Hard-Drive Configuration

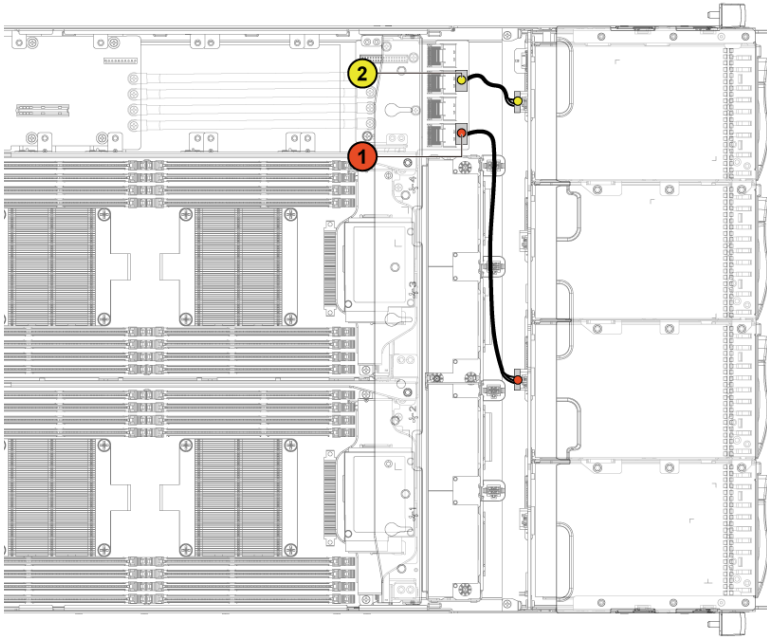

Item	Cable	From (Bottom Middle Plane)	To (Direct Backplane)
1	Hard-drive backplane cable	mini-SAS connector for system board 1 and 2 (hard drive 1,2,3 and 4) (J1)	SATA2 hard drive connectors 1,2, and 3 for system board 2 (from top to bottom)
2	Hard-drive backplane cable	mini-SAS connector for system board 3 and 4 (hard drive 1,2,3 and 4) (J3)	SATA2 hard drive connectors 1,2, and 3 for system board 4 (from top to bottom)

Figure 3-77. Cable Routing—Top Middle Plane to Direct Backplane for 24 x2.5” Hard-Drive Configuration

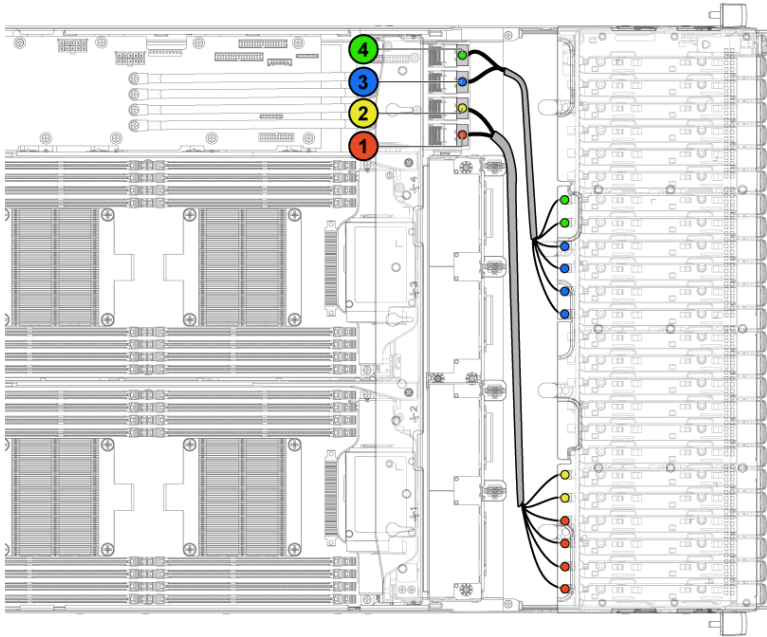

Item	Cable	From (Top Middle Plane)	To (Direct Backplane)
1	Hard-drive backplane cable	Mini-SAS connector for system board 1 and 2 (hard drive 1, 2, 3 and 4) (J1)	SATA2 hard drive connectors 1 to 4 for system board 1 (from right to left)
2	Hard-drive backplane cable	Mini-SAS connector for system board 1 and 2 (hard drive 5 and 6) (J2)	SATA2 hard drive connectors 5 to 6 for system board 1 (from right to left)
3	Hard-drive backplane cable	Mini-SAS connector for system board 3 and 4 (hard drive 1, 2, 3 and 4) (J3)	SATA2 hard drive connectors 1 to 4 for system board 3 (from right to left)

Item	Cable	From (Top Middle Plane)	To (Direct Backplane)
4	Hard-drive backplane cable	Mini-SAS connector for system board 3 and 4 (hard drive 5 and 6) (J4)	SATA2 hard drive connectors 5 to 6 for system board 3 (from right to left)

Figure 3-78. Cable Routing—Bottom Middle Plane to Direct Backplane for 24 x2.5" Hard-Drive Configuration

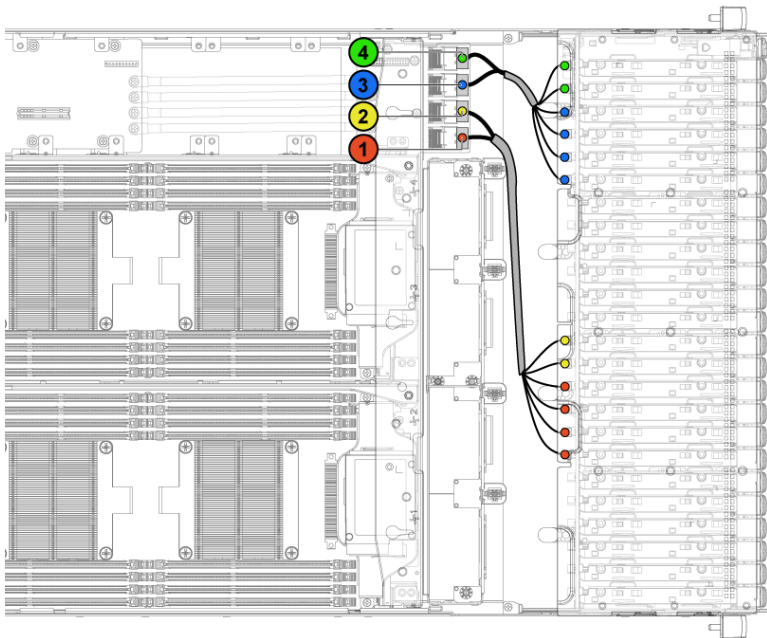

Item	Cable	From (Bottom Middle Plane)	To (Direct Backplane)
1	Hard-drive backplane cable	mini-SAS connector for system board 1 and 2 (hard drive 1,2,3 and 4) (J1)	SATA2 hard drive connectors 1 to 4 for system board 2 (from right to left)

Item	Cable	From (Bottom Middle Plane)	To (Direct Backplane)
2	Hard-drive backplane cable	mini-SAS connector for system board 1 and 2 (hard drive 5 and 6) (J2)	SATA2 hard drive connectors 5 to 6 for system board 2 (from right to left)
3	Hard-drive backplane cable	mini-SAS connector for system board 3 and 4 (hard drive 1,2,3 and 4) (J3)	SATA2 hard drive connectors 1 to 4 for system board 4 (from right to left)
4	Hard-drive backplane cable	mini-SAS connector for system board 3 and 4 (hard drive 5 and 6) (J4)	SATA2 hard drive connectors 5 to 6 for system board 4 (from right to left)

Cable Routing for Middle Plane to 2.5" Hard-Drive Backplane for Expander Configuration

Figure 3-79. Cable Routing–Top Middle Plane to 2.5" Hard Drive for Expander Configuration

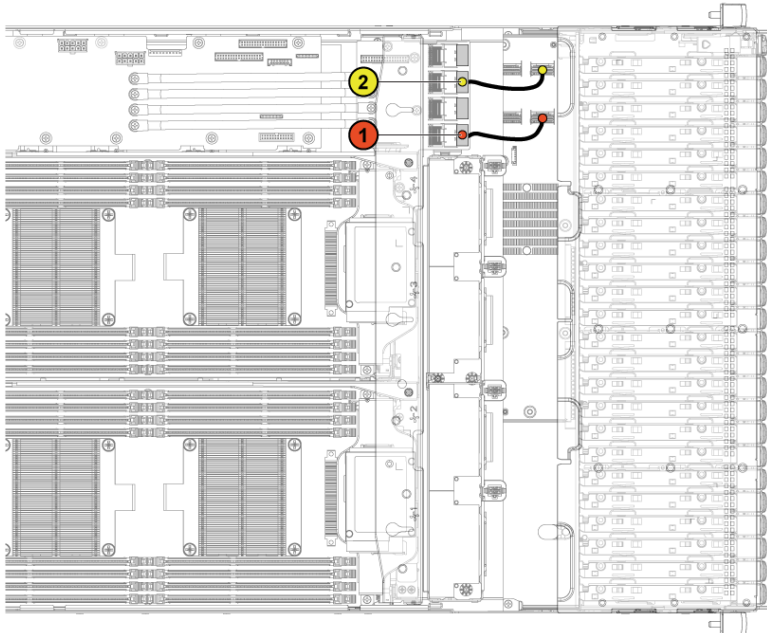

Item	Cable	From (Top Middle Plane)	To (Expander Card)
①	Hard-drive backplane cable	mini-SAS connector for system board 1 (J1)	mini-SAS connector (0~3) for system board 1
②	Hard-drive backplane cable	mini-SAS connector for system board 3 (J3)	mini-SAS connector (8~11) for system board 3

Figure 3-80. Cable Routing—Bottom Middle Plane to 2.5" Hard Drive for Expander Configuration

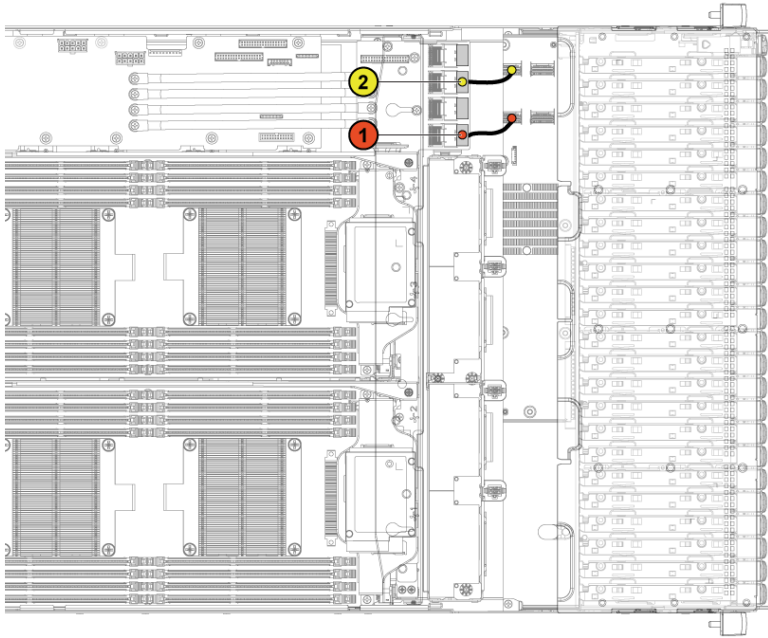

Item	Cable	From (Bottom Middle Plane)	To (Expander Card)
①	Hard-drive backplane cable	mini-SAS connector for system board 1 (J1)	mini-SAS connector (4~7) for system board 1
②	Hard-drive backplane cable	mini-SAS connector for system board 3 (J3)	mini-SAS connector (12~15) for system board 3

Direct Backplanes



NOTE: Following is the replacement procedure of SATA2 and SAS Direct Backplane for 3.5-inch hard drive systems. Replacement procedure for 2.5-inch of SATA2 and SAS Direct Backplane is similar to the Direct Backplane for 3.5-inch hard drive systems.

Removing the Direct Backplane



CAUTION: Many repairs may only be done by a certified service technician. You should only perform troubleshooting and simple repairs as authorized in your product documentation, or as directed by the online or telephone service and support team. Damage due to servicing that is not authorized by Dell is not covered by your warranty. Read and follow the safety instructions that came with the product.

- 1 It is recommended to turn off the system, including any attached peripherals, and disconnect the system from its electrical outlet.
- 2 Remove all the hard drives. See “Removing a Hard-Drive Carrier” on page 135.
- 3 Open the system. See “Opening the System” on page 218.



CAUTION: To prevent damage to the drives and backplane, you must remove the hard drives from the system before removing the backplane.



CAUTION: You must note the number of each hard drive and temporarily label them before removal so that you can replace them in the same locations.

- Disconnect all the cables from the backplane. See Figure 3-81 for 3.5-inch hard drives and Figure 3-82 for 2.5-inch hard drives.
Note the routing of the cable on the chassis as you remove them from the system. You must route these cables properly when you replace them to prevent the cables from being pinched or crimped.

Figure 3-81. Back View of the 3.5" Direct Backplane

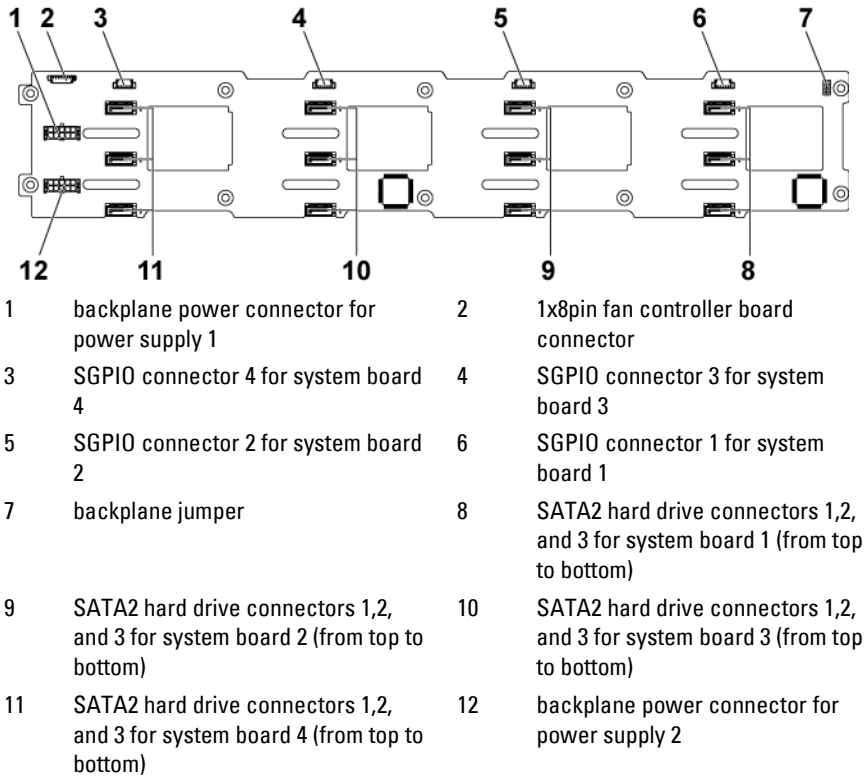
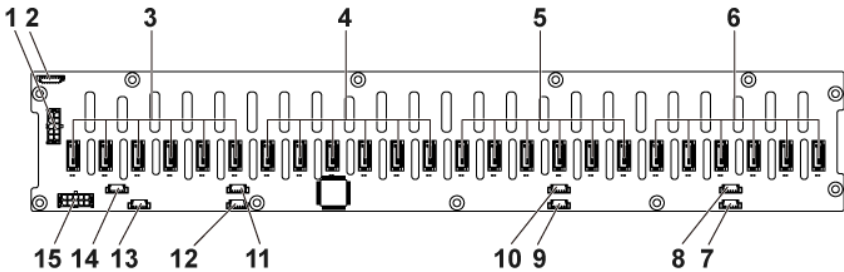

Figure 3-82. Back View of the 2.5" Direct Backplane



- | | | | |
|----|--|----|--|
| 1 | backplane power connector for power supply 1 | 2 | system fan board connector |
| 3 | SATA2 hard drive connectors 1 to 6 for system board 4 (from right to left) | 4 | SATA2 hard drive connectors 1 to 6 for system board 3 (from right to left) |
| 5 | SATA2 hard drive connectors 1 to 6 for system board 2 (from right to left) | 6 | SATA2 hard drive connectors 1 to 6 for system board 1 (from right to left) |
| 7 | SGPIO connector A for system board 1 | 8 | SGPIO connector B for system board 1 |
| 9 | SGPIO connector A for system board 2 | 10 | SGPIO connector B for system board 2 |
| 11 | SGPIO connector A for system board 3 | 12 | SGPIO connector B for system board 3 |
| 13 | SGPIO connector A for system board 4 | 14 | SGPIO Connector B for system board 4 |
| 15 | backplane power connector for power supply 2 | | |

- 5 Disconnect front panel cables from the power distribution board. See Figure 3-66.
Note the routing of the cable on the chassis as you remove them from the system. You must route these cables properly when you replace them to prevent the cables from being pinched or crimped.
- 6 Remove the screws that secure the hard-drive cage to the chassis. See Figure 3-83.

Figure 3-83. Removing and Installing the Direct Backplane

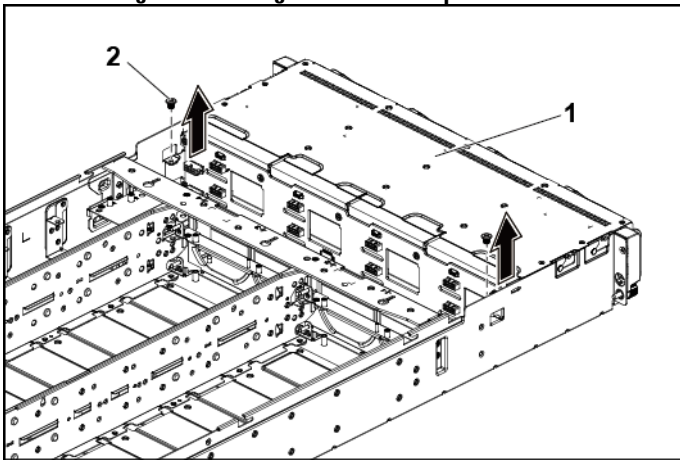

1 hard-drive cage

2 screw (2)

- 7 Remove the screws that secure the front-panel assemblies to the chassis. See Figure 3-84.
- 8 Remove the hard-drive cage from the chassis. See Figure 3-84.

Figure 3-84. Removing and Installing the Hard-Drive Cage Cable Routing for Middle Plane to Direct Backplane

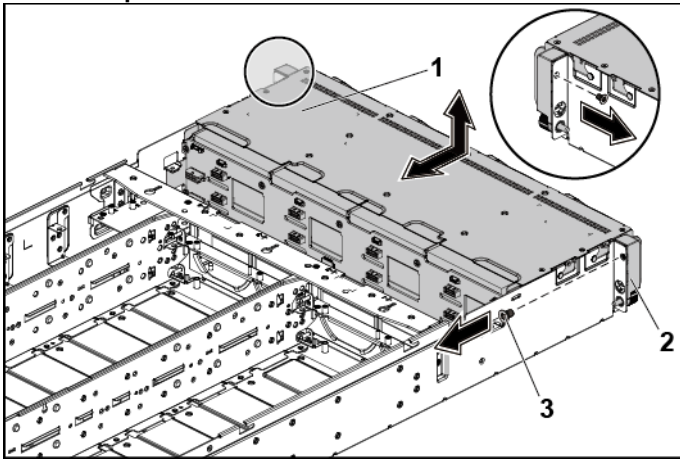

- 1 hard-drive cage
- 3 screw (2)

- 2 front-panel assembly (2)

- 9 Remove the screws that secure the backplane to the hard-drive cage. See Figure 3-85.
- 10 Remove the backplane from the hard-drive cage. See Figure 3-85.

Figure 3-85. Removing and Installing the Direct Backplane From the Hard-Drive Cage

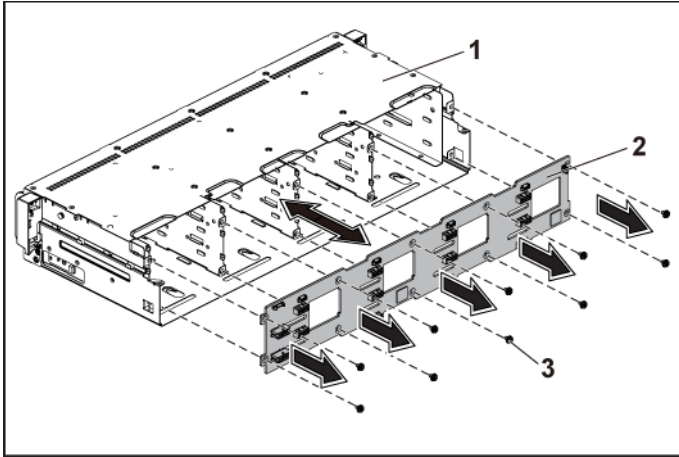

- | | | | |
|---|-----------------|---|---------------------------|
| 1 | hard-drive cage | 2 | 3.5-inch Direct Backplane |
| 3 | screw (10) | | |

Installing the Direct Backplane



CAUTION: Many repairs may only be done by a certified service technician. You should only perform troubleshooting and simple repairs as authorized in your product documentation, or as directed by the online or telephone service and support team. Damage due to servicing that is not authorized by Dell is not covered by your warranty. Read and follow the safety instructions that came with the product.

- 1 Install the backplane into the hard-drive cage. See Figure 3-85.
- 2 Replace the screws that secure the backplane to the hard-drive cage. See Figure 3-85.
- 3 Replace the hard-drive cage into the chassis. See Figure 3-84.

- 4 Replace the screws that secure the front-panel assemblies to the chassis. See Figure 3-84.
- 5 Connect all the cables to the backplane. See Figure 3-81 for 3.5-inch hard drives and Figure 3-82 for 2.5-inch hard drives.
You must route these cables properly through the tabs on the chassis to prevent them from being pinched or crimped.
- 6 Connect front panel cables to the power distribution board. See Figure 3-96. You must route these cables properly on the chassis to prevent them from being pinched or crimped.
- 7 Replace the screws that secure the hard-drive cage. See Figure 3-83.
- 8 Close the system, see “Closing the System” on page 219.
- 9 Replace the hard drives. See “Installing a Hard Drive into a Hard-Drive Carrier” on page 138.
- 10 Reconnect the system to its electrical outlet and turn on the system, including any attached peripherals.

2.5-inch Hard Drive Expander Configuration



NOTE: Following is the replacement procedure of SATA2 and SAS backplane for 2.5-inch hard drive expander configuration. The configuration can apply to 1 ~ 4 System-Boards and support up to 24 hard drives. For more information on the direction details, see the HDD Zoning configuration tool at dell.com/support.

Removing the 2.5-inch Hard Drive Backplane for Expander Configuration



CAUTION: Many repairs may only be done by a certified service technician. You should only perform troubleshooting and simple repairs as authorized in your product documentation, or as directed by the online or telephone service and support team. Damage due to servicing that is not authorized by Dell is not covered by your warranty. Read and follow the safety instructions that came with the product.

- 1 It is recommended to turn off the system, including any attached peripherals, and disconnect the system from its electrical outlet.
- 2 Remove all the hard drives. See “Removing a Hard-Drive Carrier” on page 135.
- 3 Open the system. See “Opening the System” on page 218.



CAUTION: To prevent damage to the drives and backplane, you must remove the hard drives from the system before removing the backplane.



CAUTION: You must note the number of each hard drive and temporarily label them before removal so that you can replace them in the same locations.

- 4 Disconnect all the cables from the backplane and expander card. See Figure 3-86 and Figure 3-87 for 2.5-inch hard drives expander configuration.

Note the routing of the cable on the chassis as you remove them from the system. You must route these cables properly when you replace them to prevent the cables from being pinched or crimped.

Figure 3-86. Back View of the 2.5" Hard-Drive Backplane for Expander Configuration

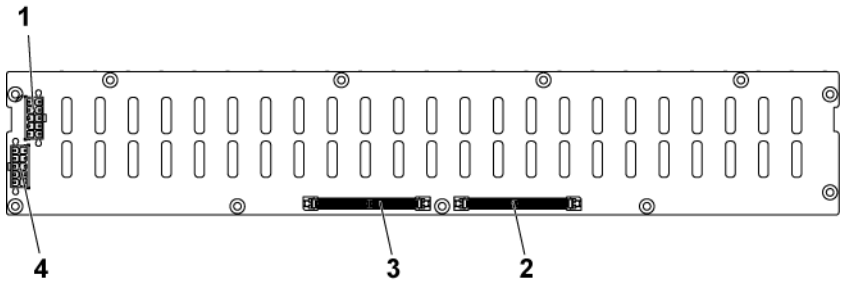

- | | | | |
|---|--|---|--|
| 1 | backplane power connector for power supply 1 | 2 | Expander-card connector 1 |
| 3 | Expander-card connector 2 | 4 | backplane power connector for power supply 2 |

Figure 3-87. Top View of the Expander Card

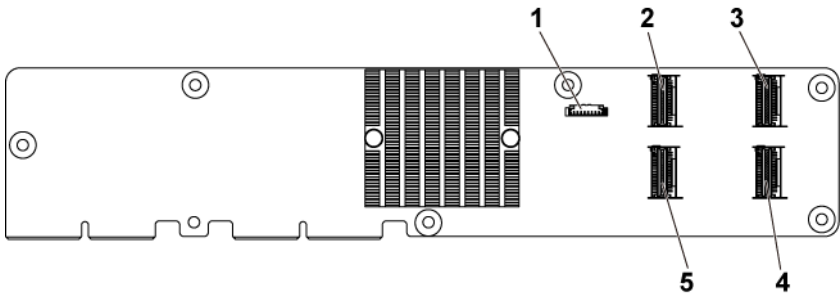

- | | | | |
|---|----------------------------|---|---------------------------|
| 1 | Power control connector | 2 | mini-SAS connector (4~7) |
| 3 | mini-SAS connector (12~15) | 4 | mini-SAS connector (8~11) |
| 5 | mini-SAS connector (0~3) | | |

- 5 Disconnect front panel cables from the power distribution board. See Figure 3-96.

Note the routing of the cable on the chassis as you remove them from the system. You must route these cables properly when you replace them to prevent the cables from being pinched or crimped.

- 6 Remove the screws that secure the hard-drive cage to the chassis. See Figure 3-88.

Figure 3-88. Removing and Installing the 2.5" Hard-Drive Backplane for Expander Configuration

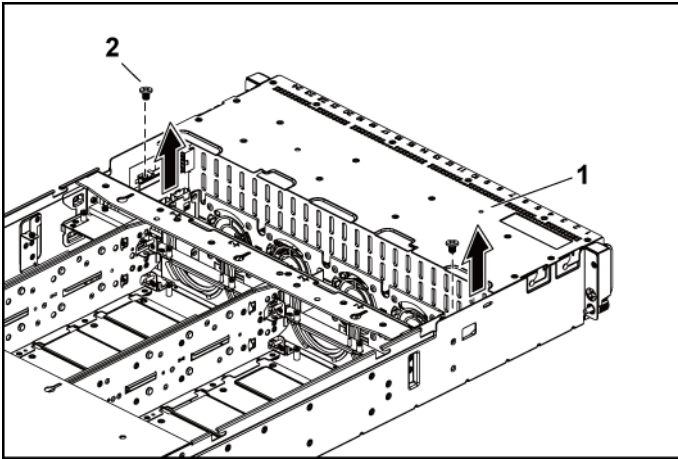

1 hard-drive cage

2 screw (2)

- 7 Remove the screws that secure the front-panel assemblies to the chassis. See Figure 3-89.
- 8 Remove the hard-drive cage from the chassis. See Figure 3-89.

Figure 3-89 Removing and Installing the 2.5" Hard-Drive Cage for Expander Configuration

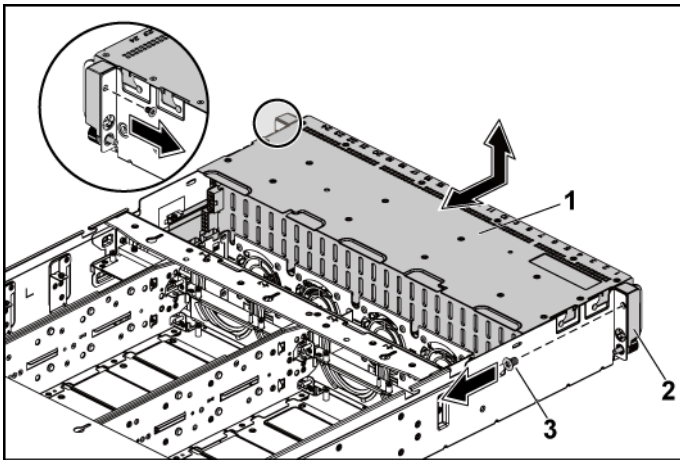

- 1 hard-drive cage
- 3 screw (2)

- 2 front-panel assembly (2)

- 9 Remove the screws that secure the expander card assembly to the hard-drive cage. See Figure 3-90.

Figure 3-90. Removing and Installing the screws securing the expander card assembly to the hard-drive cage

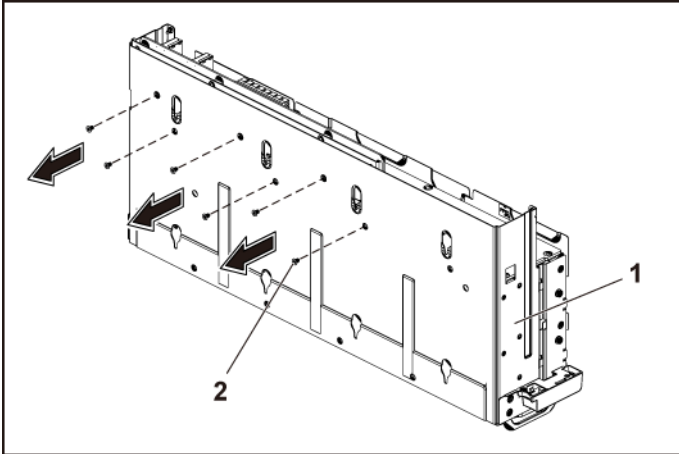

1 hard-drive cage

2 screw (6)

- 10 Remove the expander card assembly from the hard-drive cage. See Figure 3-91

Figure 3-91. Removing and Installing the 2.5" Hard-Drive Expander Card Assembly from the Hard-Drive Cage

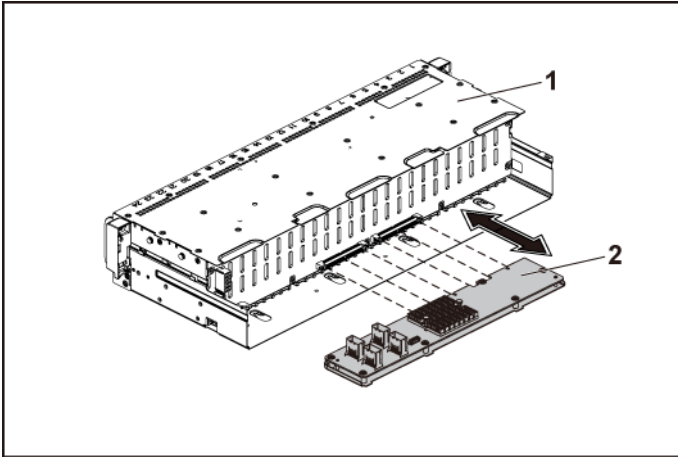

1 hard-drive cage

2 expander card assembly

- 11 Remove the screws that secure the backplane for expander configuration to the hard-drive cage. See Figure 3-92
- 12 Remove the backplane for expander configuration from the hard-drive cage. See Figure 3-92

Figure 3-92. Removing and Installing the Backplane for Expander Configuration From the Hard-Drive Cage

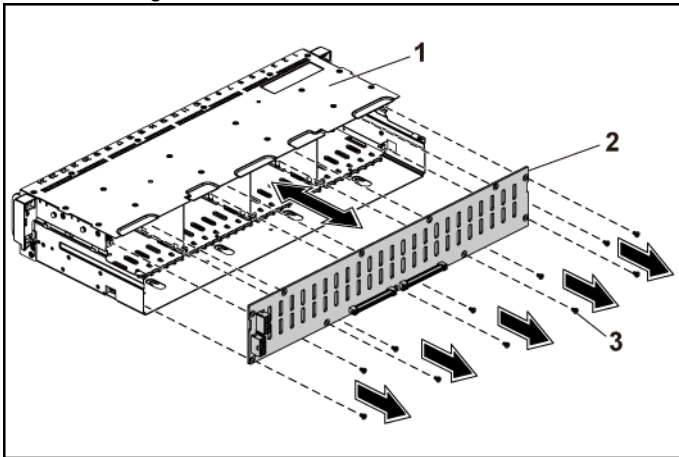

1 hard-drive cage

2 2.5-inch hard-drive backplane
for Expander Configuration

3 screw (11)

Installing the 2.5-inch Hard Drive Backplane for Expander Configuration



CAUTION: Many repairs may only be done by a certified service technician. You should only perform troubleshooting and simple repairs as authorized in your product documentation, or as directed by the online or telephone service and support team. Damage due to servicing that is not authorized by Dell is not covered by your warranty. Read and follow the safety instructions that came with the product.

- 1 Replace the backplane for expander configuration to the hard-drive cage. See Figure 3-92
- 2 Replace the screws securing the backplane for expander configuration to the hard-drive cage. See Figure 3-91
- 3 Install the expander card assembly to the hard-drive cage. See Figure 3-90.
- 4 Replace the screws that secure the expander card assembly to the hard-drive cage. See Figure 3-90.
- 5 Replace the hard-drive cage into the chassis. See Figure 3-89
- 6 Replace the screws that secure the front-panel assemblies to the chassis. See Figure 3-89.
- 7 Connect all the cables to the backplane for expander configuration and expander card. See Figure 3-86 and Figure 3-87 for 2.5-inch hard drives expander configuration.
You must route these cables properly through the tabs on the chassis to prevent them from being pinched or crimped.
- 8 Connect front panel cables to the power distribution board. See Figure 3-96. You must route these cables properly on the chassis to prevent them from being pinched or crimped.
- 9 Replace the screws that secure the hard-drive cage. See Figure 3-88..
- 10 Close the system, see “Closing the System” on page 219.
- 11 Replace the hard drives. See “Installing a Hard Drive into a Hard-Drive Carrier” on page 138.

- 12 Reconnect the system to its electrical outlet and turn on the system, including any attached peripherals.

Front Panels

Removing the Front Panel



CAUTION: Many repairs may only be done by a certified service technician. You should only perform troubleshooting and simple repairs as authorized in your product documentation, or as directed by the online or telephone service and support team. Damage due to servicing that is not authorized by Dell is not covered by your warranty. Read and follow the safety instructions that came with the product.

- 1 It is recommended to turn off the system, including any attached peripherals, and disconnect the system from the electrical outlet.
- 2 Remove all the hard drives. See “Removing a Hard-Drive Carrier” on page 135.
- 3 Open the system. See “Opening the System” on page 218.
- 4 Disconnect all the cables from the backplane. See Figure 3-81 for 3.5-inch hard drives and Figure 3-82 for 2.5-inch hard drives.
Note the routing of the cable on the chassis as you remove them from the system. You must route these cables properly when you replace them to prevent the cables from being pinched or crimped.
- 5 Disconnect front panel cables from the power distribution board. See Figure 3-96 or Figure 3-99.
Note the routing of the cable on the chassis as you remove them from the system. You must route these cables properly when you replace them to prevent the cables from being pinched or crimped.
- 6 Remove the screws that secure the hard-drive cage to the chassis. See Figure 3-83.
- 7 Remove the screws that secure the front-panel assemblies to the chassis. See Figure 3-84.
- 8 Remove the hard-drive cage from the chassis. See Figure 3-84.

- 9 Remove the screws that secure the front-panel assembly to the hard-drive cage. See Figure 3-93.
- 10 Remove the front-panel assembly from the hard-drive cage. See Figure 3-93.

Figure 3-93. Removing and Installing a Front Panel Assembly

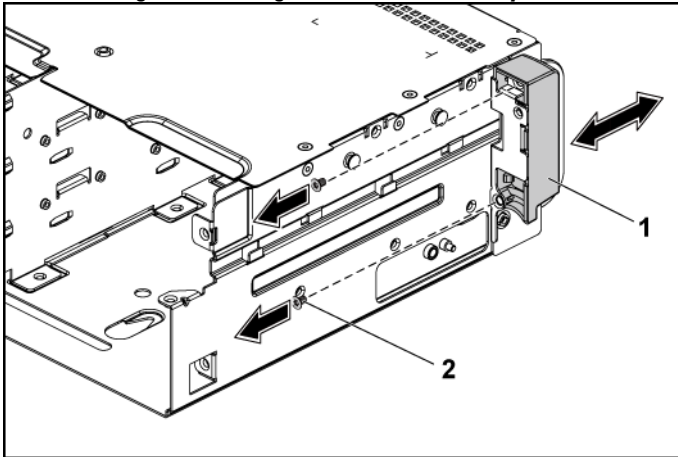

1 front-panel assembly

2 screw (2)

- 11 Push aside the retention hooks on the front-panel assembly. See Figure 3-94.
- 12 Remove the front panel from the front-panel assembly. See Figure 3-94

Figure 3-94. Removing and Installing a Front Panel

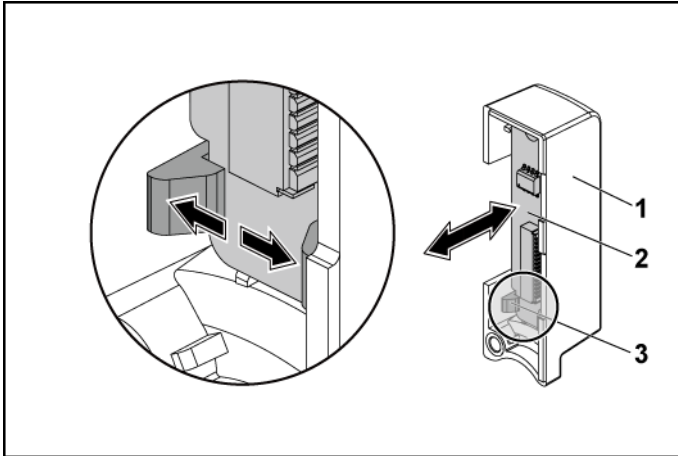

- 1 front-panel assembly
- 3 retention hooks

- 2 front panel

Installing the Front Panel



CAUTION: Many repairs may only be done by a certified service technician. You should only perform troubleshooting and simple repairs as authorized in your product documentation, or as directed by the online or telephone service and support team. Damage due to servicing that is not authorized by Dell is not covered by your warranty. Read and follow the safety instructions that came with the product.

- 1 Push aside the retention hooks on the front-panel assembly and place the front panel into the front-panel assembly. See Figure 3-94.
- 2 Replace the front-panel assembly into the hard-drive cage. See Figure 3-93.
- 3 Replace the screws that secure the front-panel assembly to the hard-

- drive cage. See Figure 3-93.
- 4 Replace the hard-drive cage into the chassis. See Figure 3-84.
 - 5 Replace the screws that secure the front-panel assemblies to the chassis. See Figure 3-84.
 - 6 Replace the screws that secure the hard-drive cage to the chassis. See Figure 3-83.
 - 7 Connect front panel cables to the power distribution board. See Figure 3-96 or Figure 3-99.
You must route these cables properly on the chassis to prevent them from being pinched or crimped.
 - 8 Connect all the cables to the backplane. See Figure 3-81 for 3.5-inch hard drives and Figure 3-82 for 2.5-inch hard drives.
You must route these cables properly on the chassis to prevent them from being pinched or crimped.
 - 9 Close the system. See “Closing the System” on page 219.
 - 10 Replace the hard drives. See “Installing a Hard Drive into a Hard-Drive Carrier” on page 138.
 - 11 Reconnect the system to its electrical outlet and turn on the system, including any attached peripherals.

Sensor Boards

Removing the Sensor Board for 3.5" Hard-Drive System



CAUTION: Many repairs may only be done by a certified service technician. You should only perform troubleshooting and simple repairs as authorized in your product documentation, or as directed by the online or telephone service and support team. Damage due to servicing that is not authorized by Dell is not covered by your warranty. Read and follow the safety instructions that came with the product.

- 1 It is recommend to turn off the system, including any attached peripherals, and disconnect the system from the electrical outlet.
- 2 Remove all the hard drives. See “Removing a Hard-Drive Carrier” on page 135.
- 3 Open the system. See “Opening the System” on page 218.
- 4 Disconnect all the cables from the backplane. See Figure 5-3 for 3.5-inch hard drives.

Note the routing of the cable on the chassis as you remove them from the system. You must route these cables properly when you replace them to prevent the cables from being pinched or crimped.

- 5 Disconnect front panel cables from the power distribution board. See Figure 3-96 or Figure 3-99.

Note the routing of the cable on the chassis as you remove them from the system. You must route these cables properly when you replace them to prevent the cables from being pinched or crimped.

- 6 Remove the hard drive cage from the chassis. See Figure 3-84.
- 7 Disconnect the cable from the sensor board. See Figure 3-96.

- 8 Remove the screw that secure the sensor board to the hard drive cage.
See Figure 3-95.
- 9 Remove the sensor board from the hard drive cage. See Figure 3-95.

Figure 3-95. Removing and Installing the Sensor Board

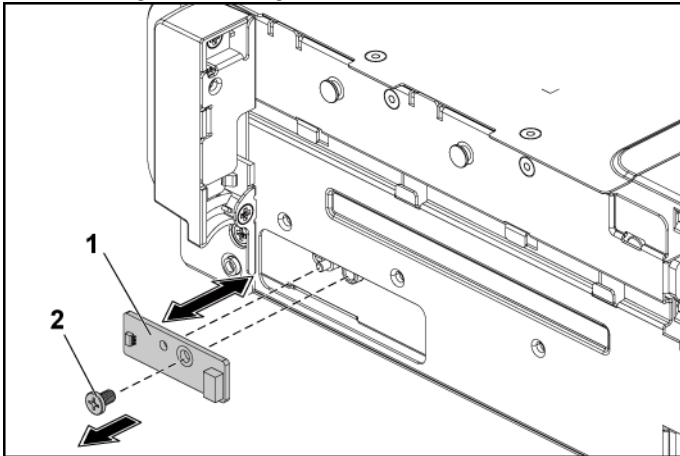

1 sensor board

2 screw

Installing the Sensor Board for 3.5" Hard-Drive System



CAUTION: Many repairs may only be done by a certified service technician. You should only perform troubleshooting and simple repairs as authorized in your product documentation, or as directed by the online or telephone service and support team. Damage due to servicing that is not authorized by Dell is not covered by your warranty. Read and follow the safety instructions that came with the product.

- 1 Replace the sensor board into the hard drive cage. See Figure 3-95.
- 2 Replace the screw that secure the sensor board to the hard drive cage.
See Figure 3-95.
- 3 Connect the sensor board cable to the sensor board. See Figure 3-96.
- 4 Replace the hard drive cage into the chassis. See Figure 3-84.

- 5 Replace the screws that secure the hard-drive cage to the chassis. See Figure 3-83.
- 6 Connect all the cables to the backplane. See Figure 3-81 for 3.5-inch hard drives.
You must route these cables properly on the chassis to prevent them from being pinched or crimped.
- 7 Connect front panel cables to the power distribution board. See Figure 3-96 or Figure 3-99.
You must route these cables properly on the chassis to prevent them from being pinched or crimped.
- 8 Close the system. See “Closing the System” on page 219.
- 9 Replace the hard drives. See “Installing a Hard Drive into a Hard-Drive Carrier” on page 138.
- 10 Reconnect the system to its electrical outlet and turn on the system, including any attached peripherals.

Cable Routing for Sensor Board and Front Panel for 3.5” Hard Drive System

- 1 Connect the Y-shaped cable for sensor board and front panel 2 to the connector on the power distribution board 1, and connect the other two ends of the cable to the connectors on the sensor board and the front panel 2 separately.
- 2 Connect the front panel cable to the connector on the power distribution board 1, and connect the other end of the cable to the connector on the front panel 1.

Figure 3-96. Cable Routing–Sensor Board and Front Panel

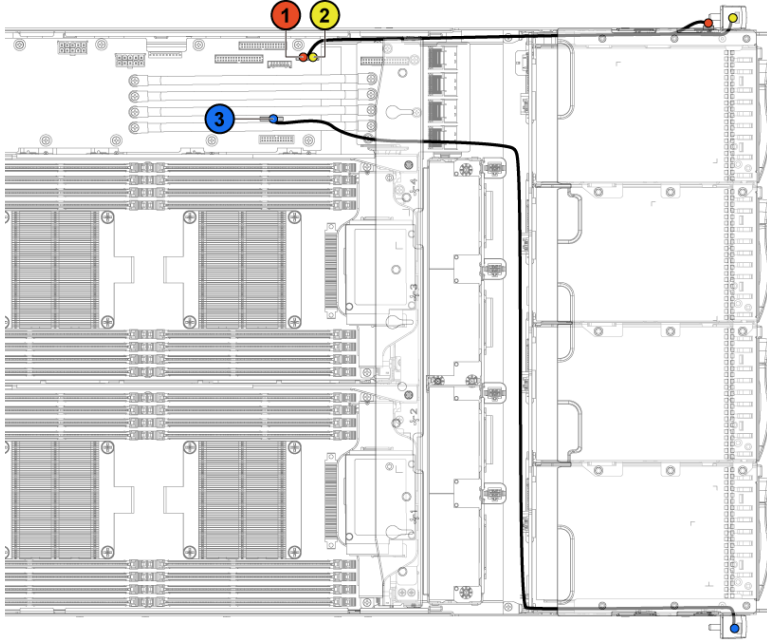

Item	Cable	From (Power Distribution Board)	To (Sensor Board and Front Panels)
1	Sensor board cable	Sensor board power connector (J1)	Sensor Board
2	Front panel cable	Front panel connector (J16)	Front Panel 2
3	Front panel cable	Front Panel connector (J18)	Front panel 1

Removing the Sensor Board for 2.5" Hard-Drive System



CAUTION: Many repairs may only be done by a certified service technician. You should only perform troubleshooting and simple repairs as authorized in your product documentation, or as directed by the online or telephone service and support team. Damage due to servicing that is not authorized by Dell is not covered by your warranty. Read and follow the safety instructions that came with the product.

- 1 It is recommended to turn off the system, including any attached peripherals, and disconnect the system from the electrical outlet.
- 2 Remove all the hard drives. See “Removing a Hard-Drive Carrier” on page 135.
- 3 Open the system. See “Opening the System” on page 218.
- 4 Disconnect all the cables from the backplane. See Figure 5-5 for 2.5-inch hard drives.

Note the routing of the cable on the chassis as you remove them from the system. You must route these cables properly when you replace them to prevent the cables from being pinched or crimped.

- 5 Disconnect front panel cables from the power distribution board. See Figure 3-96 or Figure 3-99.

Note the routing of the cable on the chassis as you remove them from the system. You must route these cables properly when you replace them to prevent the cables from being pinched or crimped.

- 6 Remove the hard drive cage from the chassis. See Figure 3-84.
- 7 Disconnect the cable from the sensor board assembly. See Figure 3-99.

- 8 Remove the screw that secures the sensor board assembly to the hard drive cage. See Figure 3-97.
- 9 Remove the sensor board assembly from the hard drive cage. See Figure 3-97.

Figure 3-97. Removing and Installing the Sensor Board Assembly

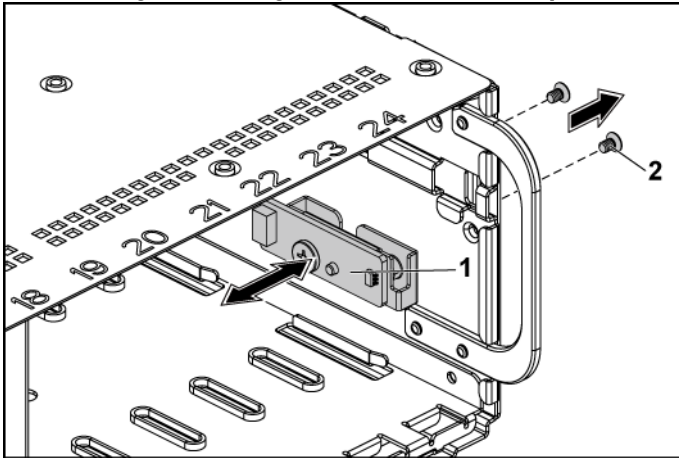

1 sensor board assembly

2 screw (2)

- 10 Remove the screw that secures the sensor board to the sensor-board holder. See Figure 3-98.
- 11 Remove the sensor board from the sensor-board holder. See Figure 3-98.

Figure 3-98. Removing and Installing the Sensor Board

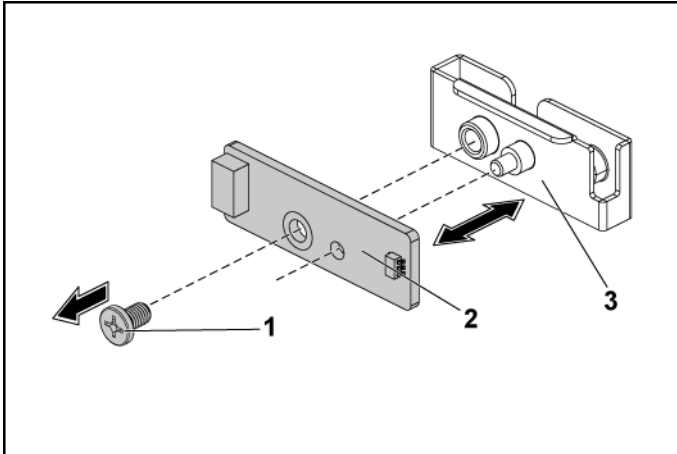

- 1 screw
- 2 sensor board
- 3 sensor-board holder

Installing the Sensor Board for 2.5" Hard-Drive System



CAUTION: Many repairs may only be done by a certified service technician. You should only perform troubleshooting and simple repairs as authorized in your product documentation, or as directed by the online or telephone service and support team. Damage due to servicing that is not authorized by Dell is not covered by your warranty. Read and follow the safety instructions that came with the product.

- 1 Replace the sensor board into the sensor-board holder. See Figure 3-98.
- 2 Replace the sensor board assembly into the hard drive cage. See Figure 3-97.

- 3 Replace the screw that secures the sensor board to the hard drive cage. See Figure 3-97.
- 4 Connect the sensor board cable to the sensor board. See Figure 3-99.
- 5 Replace the hard drive cage into the chassis. See Figure 3-84.
- 6 Replace the screws that secure the hard-drive cage to the chassis. See Figure 3-83.
- 7 Connect all the cables to the backplane. See Figure 3-82 for 2.5-inch hard drives.
You must route these cables properly on the chassis to prevent them from being pinched or crimped.
- 8 Connect front panel cables to the power distribution board. See Figure 3-96 or Figure 3-99.
You must route these cables properly on the chassis to prevent them from being pinched or crimped.
- 9 Close the system. See “Closing the System” on page 219.
- 10 Replace the hard drives. See “Installing a Hard Drive into a Hard-Drive Carrier” on page 138.
- 11 Reconnect the system to its electrical outlet and turn on the system, including any attached peripherals.

Cable Routing for Sensor Board and Front Panel for 2.5” Hard Drive System

- 1 Connect the Y-shaped cable for sensor board and front panel 2 to the connector on the power distribution board 1, and connect the other two ends of the cable to the connectors on the sensor board and the front panel 2 respectively.
- 2 Connect the front panel cable to the connector on the power distribution board 1, and connect the other end of the cable to the connector on the front panel 1.

Figure 3-99. Cable Routing–Sensor Board and Front Panel

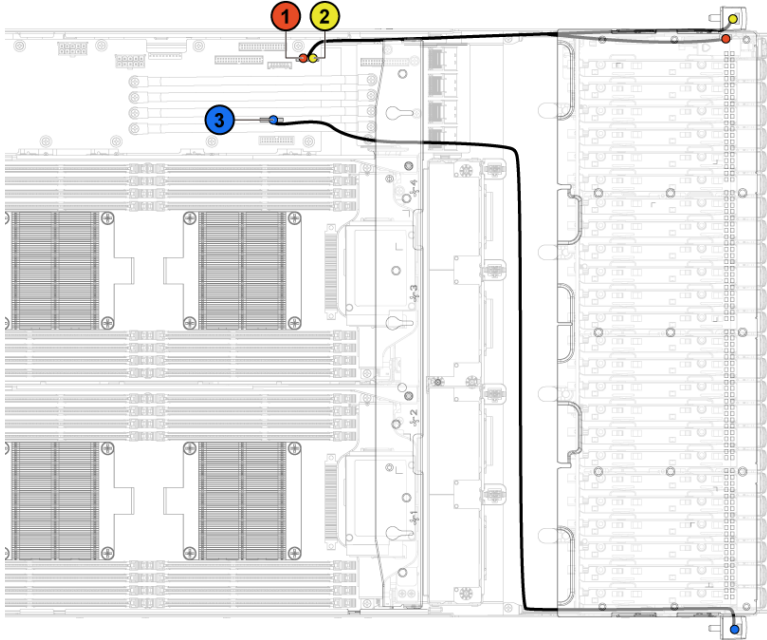

Item	Cable	From (Power Distribution Board)	To (Sensor Board and Front Panels)
1	Sensor board cable	Sensor board power connector (J1)	Sensor Board
2	Front panel cable	Front panel connector (J16)	Front Panel 2
3	Front panel cable	Front Panel connector (J18)	Front panel 1

Troubleshooting Your System

Minimum Configuration to POST

- One Power Supply
- One Processor (CPU) in socket CPU1 (minimum for troubleshooting)
- One Memory Module (DIMM) installed in the socket A1



NOTE: The three items above are the minimum configuration to POST. When the PCI-E slot 1 and slot 2 are to be used, the processor 1 must be installed; when the PCI-E slot 3 is to be used, both the processor 1 and processor 2 must be installed.

Safety First – For You and Your System



WARNING: Whenever you need to lift the system, get others to assist you. To avoid injury, do not attempt to lift the system by yourself.



WARNING: Before removing the system cover, disconnect all power, then unplug the AC power cord, and then disconnect all peripherals, and all LAN lines.



CAUTION: Many repairs may only be done by a certified service technician. You should only perform troubleshooting and simple repairs as authorized in your product documentation, or as directed by the online or telephone service and support team. Damage due to servicing that is not authorized by Dell is not covered by your warranty. Read and follow the safety instructions that came with the product.

Installation Problems

Perform the following checks when you troubleshoot installation problems:

- Check all cable and power connections (including all rack cable connections).
- Unplug the power cord and wait for one minute. Then reconnect the power cord and try again.
- If the network is reporting an error, verify that the system has enough memory and disk space.
- Remove all added peripherals, one at a time, and try to turn on the system. If after removing a peripheral the system works, it may be a problem with the peripheral or a configuration problem between the peripheral and the system. Contact the peripheral vendor for assistance.
- If the system does not power on, check the LED display. If the power LED is not on, you may not be receiving AC power. Check the AC power cord to make sure that it is securely connected.

Troubleshooting System Startup Failure

If your system halts during startup, especially after installing an operating system or reconfiguring your system's hardware, check for invalid memory configurations. These could cause the system to halt at startup without any video output.

For all other startup issues, note any system messages that appear onscreen. See “Using the System Setup Program” on page 58 for more information.

Troubleshooting External Connections

Ensure that all external cables are securely attached to the external connectors on your system before troubleshooting any external devices. See Figure 1-1 to Figure 1-6, and Figure 1-18, Figure 1-19 for the front- and back-panel connectors on your system.

Troubleshooting the Video Subsystem

- 1 Check the system and power connections to the monitor.
- 2 Check the video interface cabling from the system to the monitor.

Troubleshooting a USB Device

Use the following steps to troubleshoot a USB keyboard and/or mouse. For other USB devices, go to step 5.

- 1 Disconnect the keyboard and mouse cables from the system briefly and reconnect them.
- 2 Connect the keyboard/mouse to the USB port(s) on the opposite side of the system.
- 3 If the problem is resolved, restart the system, enter the System Setup program, and check if the nonfunctioning USB ports are enabled.
- 4 Replace the keyboard/mouse with another working keyboard/mouse. If the problem is resolved, replace the faulty keyboard/mouse. If the problem is not resolved, proceed to the next step to begin troubleshooting the other USB devices attached to the system.
- 5 Power down all attached USB devices and disconnect them from the system.
- 6 Restart the system and, if your keyboard is functioning, enter the system setup program. Verify that all USB ports are enabled. See “USB Configuration” on page 88. If your keyboard is not functioning, you can also use remote access. If the system is not accessible, see “Jumper Settings” on page 308 for instructions on setting the NVRAM_CLR jumper inside your system and restoring the BIOS to the default settings.
- 7 Reconnect and power on each USB device one at a time.
- 8 If a device causes the same problem, power down the device, replace the USB cable, and power up the device.

If the problem persists, replace the device.

If all troubleshooting fails, see “Getting Help” on page 310.

Troubleshooting a Serial I/O Device

- 1 Turn off the system and any peripheral devices connected to the serial port.
- 2 Swap the serial interface cable with another working cable, and turn on the system and the serial device.
If the problem is resolved, replace the interface cable.
- 3 Turn off the system and the serial device, and swap the device with a comparable device.
- 4 Turn on the system and the serial device.
If the problem is resolved, replace the serial device.
If the problem persists, see “Getting Help” on page 310.

Troubleshooting a NIC

- 1 Restart the system and check for any system messages pertaining to the NIC controller.
- 2 Check the appropriate indicator on the NIC connector. See “LAN Indicators (Management Port)” on page 30.
 - If the link indicator does not light, check all cable connections.
 - If the activity indicator does not light, the network driver files might be damaged or missing.
Remove and reinstall the drivers if applicable. See the NIC’s documentation.
 - Change the auto-negotiation setting, if possible.
 - Use another connector on the switch or hub.If you are using a NIC card instead of an integrated NIC, see the documentation for the NIC card.

- 3 Ensure that the appropriate drivers are installed and the protocols are bound. See the NIC's documentation.
- 4 Enter the System Setup program and confirm that the NIC ports are enabled. See "Using the System Setup Program" on page 58.
- 5 Ensure that the NICs, hubs, and switches on the network are all set to the same data transmission speed. See the documentation for each network device.
- 6 Ensure that all network cables are of the proper type and do not exceed the maximum length.
If all troubleshooting fails, see "Getting Help" on page 310.

Troubleshooting a Wet System



CAUTION: Many repairs may only be done by a certified service technician. You should only perform troubleshooting and simple repairs as authorized in your product documentation, or as directed by the online or telephone service and support team. Damage due to servicing that is not authorized by Dell is not covered by your warranty. Read and follow the safety instructions that came with the product.

- 1 Turn off the system and attached peripherals, and disconnect the system from the electrical outlet.
- 2 Open the system. See "Opening the System" on page 218.
- 3 Disassemble components from the system. See "Installing System Components" on page 130.
 - Hard drives
 - SAS backplane
 - Expansion-card
 - Power supplies
 - Fans
 - Processors and heat sinks
 - Memory modules
- 4 Let the system dry thoroughly for at least 24 hours.

- 5 Reinstall the components you removed in step 3.
- 6 Close the system. See “Closing the System” on page 219.
- 7 Reconnect the system to the electrical outlet, and turn on the system and attached peripherals.
If the system does not start properly, see “Getting Help” on page 310.
- 8 If the system starts properly, shut down the system and reinstall the expansion card that you removed. See “Installing the Expansion Card” on page 157.
- 9 If the system fails to start, see “Getting Help” on page 310.

Troubleshooting a Damaged System



CAUTION: Many repairs may only be done by a certified service technician. You should only perform troubleshooting and simple repairs as authorized in your product documentation, or as directed by the online or telephone service and support team. Damage due to servicing that is not authorized by Dell is not covered by your warranty. Read and follow the safety instructions that came with the product.

- 1 Turn off the system and attached peripherals, and disconnect the system from the electrical outlet.
- 2 Open the system. See “Opening the System” on page 218.
- 3 Ensure that the following components are properly installed:
 - Expansion-card assembly
 - Power supplies
 - Fans
 - Processors and heat sinks
 - Memory modules
 - Hard-drive carriers
- 4 Ensure that all cables are properly connected.
- 5 Close the system. See “Closing the System” on page 219.
- 6 If the system fails to start, see “Getting Help” on page 310.

Troubleshooting the System Battery



NOTE: If the system is turned off for long periods of time (for weeks or months), the NVRAM may lose its system configuration information. This situation is caused by a defective battery.

- 1 Re-enter the time and date through the System Setup program. See “System Setup Options at Boot” on page 58.
- 2 Turn off the system and disconnect it from the electrical outlet for at least one hour.
- 3 Reconnect the system to the electrical outlet and turn on the system.
- 4 Enter the System Setup program.

If the date and time are not correct in the System Setup program, replace the battery. See “Replacing the System Battery” on page 214.



CAUTION: Many repairs may only be done by a certified service technician. You should only perform troubleshooting and simple repairs as authorized in your product documentation, or as directed by the online or telephone service and support team. Damage due to servicing that is not authorized by Dell is not covered by your warranty. Read and follow the safety instructions that came with the product.

If the problem is not resolved by replacing the battery, see “Getting Help” on page 310.



NOTE: Some software may cause the system time to speed up or slow down. If the system seems to operate normally except for the time kept in the System Setup program, the problem may be caused by software rather than by a defective battery.

Troubleshooting Power Supplies

- 1 Identify the faulty power supply by the power supply's fault indicator. See “Power and System Board Indicator Codes” on page 31.



CAUTION: At least one power supply must be installed for the system to operate. Operating the system with only one power supply installed for extended periods of time can cause the system to overheat.

- 2 Reseat the power supply by removing and reinstalling it. See “Power Supplies” on page 138.



NOTE: After installing a power supply, allow several seconds for the system to recognize the power supply and to determine if it is working properly. The power indicator turns green to signify that the power supply is functioning properly.

If the problem persists, replace the faulty power supply.

- 3 If all troubleshooting fails, see “Getting Help” on page 310.

Troubleshooting System Cooling Problems



CAUTION: Many repairs may only be done by a certified service technician. You should only perform troubleshooting and simple repairs as authorized in your product documentation, or as directed by the online or telephone service and support team. Damage due to servicing that is not authorized by Dell is not covered by your warranty. Read and follow the safety instructions that came with the product.

Ensure that none of the following conditions exist:

- System cover, cooling shroud, drive blank, power supply blank, or front or back filler panel is removed.
- Ambient temperature is too high.
- External airflow is obstructed.
- Cables inside the system obstruct airflow.
- An individual cooling fan is removed or has failed. See “Troubleshooting a Fan” on page 286.

Troubleshooting a Fan



CAUTION: Many repairs may only be done by a certified service technician. You should only perform troubleshooting and simple repairs as authorized in your product documentation, or as directed by the online or telephone service and support team. Damage due to servicing that is not authorized by Dell is not covered by your warranty. Read and follow the safety instructions that came with the product.

- 1 Locate the faulty fan indicated by the diagnostic software.
- 2 Turn off the system and all attached peripherals.
- 3 Open the system. See “Opening the System” on page 218.
- 4 Reseat the fan’s power cable.
- 5 Restart the system.

If the fan functions properly, close the system. See “Closing the System” on page 219.

- 6 If the fan does not function, turn off the system and install a new fan. See “Cooling Fans” on page 220.
- 7 Restart the system.

If the problem is resolved, close the system. See “Closing the System” on page 219.

If the replacement fan does not operate, see “Getting Help” on page 310.

Troubleshooting System Memory



CAUTION: Many repairs may only be done by a certified service technician. You should only perform troubleshooting and simple repairs as authorized in your product documentation, or as directed by the online or telephone service and support team. Damage due to servicing that is not authorized by Dell is not covered by your warranty. Read and follow the safety instructions that came with the product.



NOTE: Invalid memory configurations can cause your system to halt at startup without video output. See “System Memory” on page 208 and verify that your memory configuration complies with all applicable guidelines.

- 1 If the system is not operational, turn off the system and attached peripherals, and unplug the system from the power source. Wait at least 10 seconds and then reconnect the system to power.
- 2 Turn on the system and attached peripherals and note the messages on the screen.
Go to step 10 if an error message appears indicating a fault with a specific memory module.
- 3 Enter the System Setup program and check the system memory settings.
See “Main Screen” on page 66. Make any changes to the memory settings, if needed.
If the memory settings match the installed memory but a problem is still indicated, go to step 10.
- 4 Turn off the system and attached peripherals, and disconnect the system from the electrical outlet.
- 5 Remove the system-board assembly. See “Removing a System-Board Assembly” on page 142.
- 6 Reseat the memory modules in their sockets. See “Installing the Memory Modules” on page 212.
- 7 Install the system-board assembly. See “Installing a System-Board

- Assembly” on page 143.
- 8 Reconnect the system to its electrical outlet, and turn on the system and attached peripherals.
 - 9 Enter the System Setup program and check the system memory settings. See “Main Screen” on page 66.
If the problem is not resolved, proceed with the next step.
 - 10 Turn off the system and attached peripherals, and disconnect the system from the power source.
 - 11 Remove the system-board assembly. See “Removing a System-Board Assembly” on page 142.
 - 12 If a diagnostic test or error message indicates a specific memory module as faulty, swap or replace the module.
 - 13 To troubleshoot an unspecified faulty memory module, replace the memory module in the first memory module socket with a module of the same type and capacity. See “Installing the Memory Modules” on page 212.
 - 14 Install the system-board assembly. See “Removing a System-Board Assembly” on page 142.
 - 15 Reconnect the system to its electrical outlet, and turn on the system and attached peripherals.
 - 16 As the system boots, observe any error message that appears and the diagnostic indicators on the front of the system.
 - 17 If the memory problem is still indicated, repeat step 10 through step 16 for each memory module installed.
If the problem persists after all memory modules have been checked, see “Getting Help” on page 310.

Troubleshooting a Hard Drive



CAUTION: Many repairs may only be done by a certified service technician. You should only perform troubleshooting and simple repairs as authorized in your product documentation, or as directed by the online or telephone service and support team. Damage due to servicing that is not authorized by Dell is not covered by your warranty. Read and follow the safety instructions that came with the product.



CAUTION: This troubleshooting procedure can destroy data stored on the hard drive. Before you proceed, back up all files on the hard drive.

- 1 If your system has a RAID controller and your hard drives are configured in a RAID array, perform the following steps:
 - a. Restart the system and enter the host adapter configuration utility program by pressing <Ctrl><H> for LSI 9265 or <Ctrl><C> for a LSI SAS 2008 mezzanine card.
See the documentation supplied with the host adapter for information about the configuration utility.
 - b. Ensure that the hard drive(s) have been configured correctly for the RAID array.
 - c. Take the hard drive offline and reseal the drive. See “Removing a System-Board Assembly” on page 142.
 - d. Exit the configuration utility and allow the system to boot to the operating system.
- 2 Ensure that the required device drivers for your controller card are installed and are configured correctly. See the operating system documentation for more information.
- 3 Restart the system, enter the System Setup program, and verify that the controller is enabled and the drives appear in the System Setup program.
See “Using the System Setup Program” on page 58.
If the problem persists, see “Getting Help” on page 310.

Troubleshooting a Storage Controller



NOTE: When troubleshooting a SAS RAID controller, also see the documentation for your operating system and the controller.

- 1 Enter the System Setup program and ensure that the SAS controller is enabled. See “Using the System Setup Program” on page 58.
- 2 Restart the system and press the applicable key sequence to enter the configuration utility program.
 - <Ctrl><C> for a LSI SAS 2008 mezzanine card
 - <Ctl><H> for a LSI 9265-8i SAS RAID CardSee the controller’s documentation for information about configuration settings.
- 3 Check the configuration settings, make any necessary corrections, and restart the system.



CAUTION: Many repairs may only be done by a certified service technician. You should only perform troubleshooting and simple repairs as authorized in your product documentation, or as directed by the online or telephone service and support team. Damage due to servicing that is not authorized by Dell is not covered by your warranty. Read and follow the safety instructions that came with the product.

- 4 Turn off the system and attached peripherals, and disconnect the system from its electrical outlet.
- 5 Remove the system-board assembly. See “Removing a System-Board Assembly” on page 142.
- 6 Ensure that the controller card is firmly seated into the system board connector. See “Installing the Expansion Card” on page 157.
- 7 If you have a battery-cached SAS RAID controller, ensure that the RAID battery is properly connected and, if applicable, the memory module on the RAID card is properly seated.
- 8 Ensure that the cables are firmly connected to the storage controller and the SAS backplane board.

- 9 Install the system-board assembly. See “Installing a System-Board Assembly” on page 143.
- 10 Reconnect the system to its electrical outlet, and turn on the system and attached peripherals.
If the problem persists, see “Getting Help” on page 310.

Troubleshooting Expansion Cards



NOTE: When troubleshooting an expansion card, see the documentation for your operating system and the expansion card.



CAUTION: Many repairs may only be done by a certified service technician. You should only perform troubleshooting and simple repairs as authorized in your product documentation, or as directed by the online or telephone service and support team. Damage due to servicing that is not authorized by Dell is not covered by your warranty. Read and follow the safety instructions that came with the product.

- 1 Turn off the system and attached peripherals, and disconnect the system from the electrical outlet.
- 2 Remove the system-board assembly. See “Removing a System-Board Assembly” on page 142.
- 3 Ensure that each expansion card is firmly seated in its connector. See “Installing the Expansion Card” on page 157.
- 4 Install the system-board assembly. See “Installing a System-Board Assembly” on page 143.
- 5 Reconnect the system to the electrical outlet, and turn on the system and attached peripherals.
- 6 If the problem is not resolved, see “Getting Help” on page 310.

Troubleshooting Processors



CAUTION: Many repairs may only be done by a certified service technician. You should only perform troubleshooting and simple repairs as authorized in your product documentation, or as directed by the online or telephone service and support team. Damage due to servicing that is not authorized by Dell is not covered by your warranty. Read and follow the safety instructions that came with the product.

- 1 Turn off the system and attached peripherals, and disconnect the system from the electrical outlet.
- 2 Remove the system-board assembly. See “Removing a System-Board Assembly” on page 142.
- 3 Ensure that each processor and heat sink are properly installed. See “Installing a Processor” on page 149.
- 4 Install the system-board assembly. See “Installing a System-Board Assembly” on page 143.
- 5 Reconnect the system to the electrical outlet, and turn on the system and attached peripherals.
- 6 If the problem persists, turn off the system and attached peripherals, and disconnect the system from the electrical outlet.
- 7 Remove the system-board assembly. See “Removing a System-Board Assembly” on page 142.
- 8 Remove processor 2. See “Removing a Processor” on page 147.
- 9 Install the system-board assembly. See “Installing a System-Board Assembly” on page 143.
- 10 Reconnect the system to the electrical outlet, and turn on the system and attached peripherals.
If the problem persists, the processor is faulty. See “Getting Help” on page 310.
- 11 Turn off the system and attached peripherals, and disconnect the system from the electrical outlet.

- 12 Remove the system-board assembly. See “Removing a System-Board Assembly” on page 142.
- 13 Replace processor 1 with processor 2. See “Installing a Processor” on page 149.
- 14 Repeat step 9 through step 11.
If you have tested both the processors and the problem persists, the system board is faulty. See “Getting Help” on page 310.

IRQ Assignment Conflicts

Most PCI devices can share an IRQ with another device, but they cannot use an IRQ simultaneously. To avoid this type of conflict, see the documentation for each PCI device for specific IRQ requirements.

Table 4-1. Assignment Specific IRQ Requirements

IRQ Line	Assignment
IRQ0	8254 timer
IRQ1	Keyboard controller
IRQ2	Cascade for IRQ9
IRQ3	Serial port (COM2) or PCI_IRQ_POOL_DEFINITION
IRQ4	Serial port (COM1) or PCI_IRQ_POOL_DEFINITION
IRQ5	PCI_IRQ_POOL_DEFINITION
IRQ6	PCI_IRQ_POOL_DEFINITION
IRQ7	RESERVE
IRQ8	RTC
IRQ9	PCI_IRQ_POOL_DEFINITION
IRQ10	PCI_IRQ_POOL_DEFINITION
IRQ11	PCI_IRQ_POOL_DEFINITION
IRQ12	Mouse controller
IRQ13	Processor
IRQ14	Primary IDE controller
IRQ15	Secondary IDE controller



NOTE: PCI_IRQ_POOL_DEFINITION means BIOS code assign in runtime.

Jumpers and Connectors

System Board Connectors

This section provides specific information about the system jumpers. It also provides some basic information on jumpers and switches and describes the connectors on the various boards in the system.

Figure 5-1. System Board Connectors

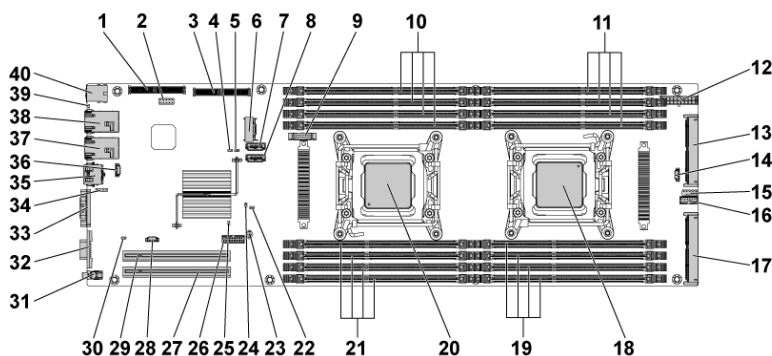

- | | | | |
|----|--------------------------------|----|----------------------------|
| 1 | PCI-E Gen3 x8 mezzanine slot 3 | 2 | internal USB connector |
| 3 | internal SAS mezzanine slot | 4 | service mode jumper |
| 5 | NVRAM clear jumper | 6 | mini-SAS connector 0 |
| 7 | onboard SATA connector 4 | 8 | onboard SATA Connector 5 |
| 9 | system battery | 10 | DIMM slots for processor 1 |
| 11 | DIMM slots for processor 2 | 12 | main power connector |
| 13 | middle plane connector | 14 | SGPIO connector 2 |
| 15 | internal serial connector | 16 | front panel connector 1 |
| 17 | PCI-E Gen3 x16 slot 4 | 18 | processor 2 |

19	DIMM slots for processor 2	20	processor 1
21	DIMM slots for processor 1	22	BIOS recovery jumper
23	PWRD_EN jumper	24	ME firmware recovery jumper
25	MEDBG1 jumper	26	LAN LED connector
27	PCI-E Gen2 x16 slot 1	28	SGPIO connector 1
29	PCI-E Gen2 x16 slot 2	30	power button pass jumper
31	power button/power & system LED	32	VGA port
33	serial port	34	BMC console connector
35	management port	36	LAN management port
37	LAN connector 2	38	LAN connector 1
39	ID LED	40	dual USB port



NOTE: The PCI-E Gen2 x16 slot 1 and slot 2 are supported up to Gen2 5.0 Gigabits bandwidth. If user inserts Gen3.0 devices into the 2 slots that will only train at Gen 2.0 speed, not Gen 3.0.

Backplane Connectors

3.5" Hard-Drive Direct Backplane

Figure 5-2. Front View of the Backplane

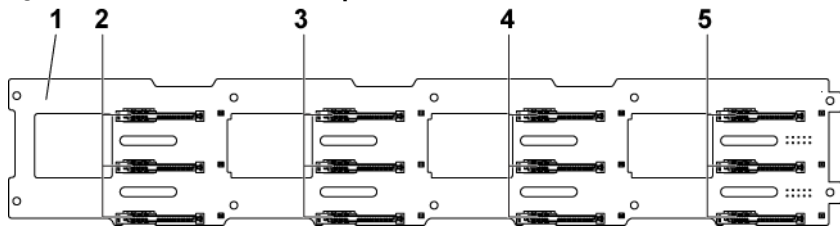

1

3

3.5"
backplane

SATA2 and
SAS
connector
1,2 and 3

for system board 2 (from top to bottom)
SATA2 and SAS connectors 1,2 and 3 for system board 4 (from top to bottom)

Figure 5-3. Back View of the Backplane

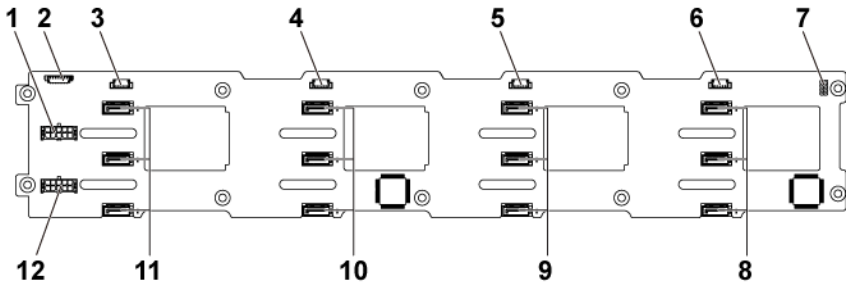

- | | |
|---|---|
| <p>1 backplane power connector for power supply 1</p> <p>3 SGPIO connector 4 for system board 4</p> <p>5 SGPIO connector 2 for system board 2</p> <p>7 backplane jumper</p> <p>9 SATA2 hard drive connectors 1,2, and 3 for system board 2 (from top to bottom)</p> | <p>2 1x8pin fan controller board connector</p> <p>4 SGPIO connector 3 for system board 3</p> <p>6 SGPIO connector 1 for system board 1</p> <p>8 SATA2 hard drive connectors 1,2, and 3 for system board 1 (from top to bottom)</p> <p>10 SATA2 hard drive connectors 1,2, and 3 for system board 3 (from top to bottom)</p> |
|---|---|

- | | | | |
|----|--|----|--|
| 11 | SATA2 hard drive connectors 1,2, and 3 for system board 4 (from top to bottom) | 12 | backplane power connector for power supply 2 |
|----|--|----|--|

2.5" Hard-Drive Direct Backplane

Figure 5-4. Front View of the Backplane

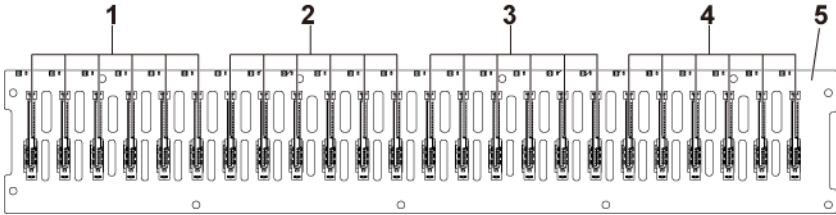

- | | | | |
|---|---|---|---|
| 1 | SATA2 and SAS connectors 1 to 6 for system board 1 (from left to right) | 2 | SATA2 and SAS connectors 1 to 6 for system board 2 (from left to right) |
| 3 | SATA2 and SAS connectors 1 to 6 for system board 3 (from left to right) | 4 | SATA2 and SAS connectors 1 to 6 for system board 4 (from left to right) |
| 5 | 2.5" backplane | | |

Figure 5-5. Back View of the Backplane

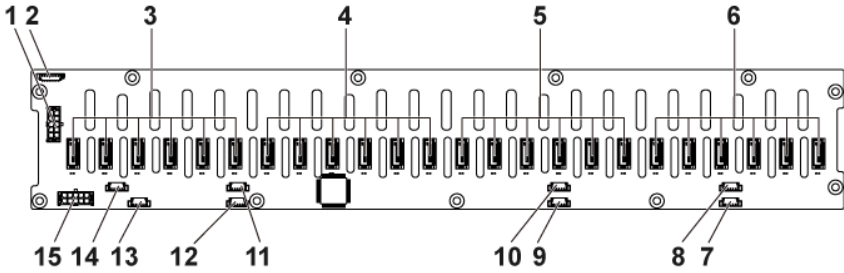

- | | | | |
|----|--|----|--|
| 1 | backplane power connector for power supply 1 | 2 | system fan board connector |
| 3 | SATA2 hard drive connectors 1 to 6 for system board 4 (from right to left) | 4 | SATA2 hard drive connectors 1 to 6 for system board 3 (from right to left) |
| 5 | SATA2 hard drive connectors 1 to 6 for system board 2 (from right to left) | 6 | SATA2 hard drive connectors 1 to 6 for system board 1 (from right to left) |
| 7 | SGPIO connector A for system board 1 | 8 | SGPIO connector B for system board 1 |
| 9 | SGPIO connector A for system board 2 | 10 | SGPIO connector B for system board 2 |
| 11 | SGPIO connector A for system board 3 | 12 | SGPIO connector B for system board 3 |
| 13 | SGPIO connector A for system board 4 | 14 | SGPIO Connector B for system board 4 |
| 15 | backplane power connector for power supply 2 | | |

2.5" Hard-Drive Expander Backplane

Figure 5-6. Front View of the Backplane

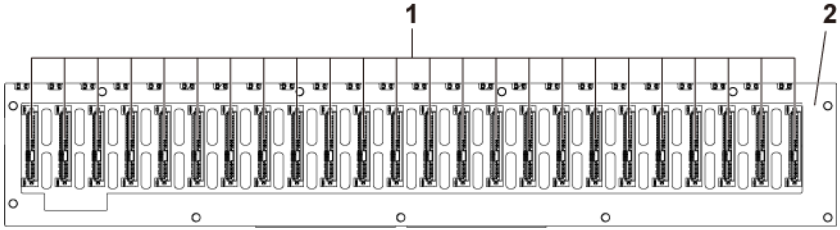

- | | | | |
|---|---|---|---|
| 1 | SATA2 and SAS connectors 1 to 24 (from left to right) | 2 | 2.5" backplane for expander configuration |
|---|---|---|---|

Figure 5-7. Back View of the Backplane

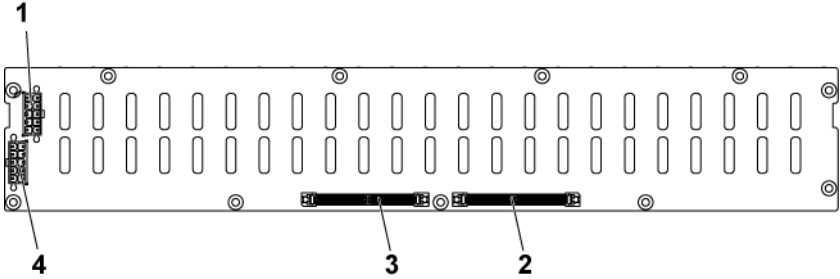

- | | | | |
|---|--|---|--|
| 1 | backplane power connector for power supply 1 | 2 | Expander-card connector 1 |
| 3 | Expander-card connector 2 | 4 | backplane power connector for power supply 2 |

Figure 3-8. Top View of the 2.5" Hard-Drive Expander Card

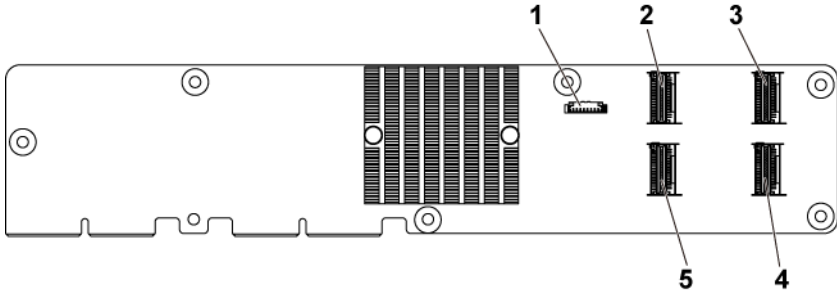

- | | | | |
|---|----------------------------|---|---------------------------|
| 1 | Power control connector | 2 | mini-SAS connector (4~7) |
| 3 | mini-SAS connector (12~15) | 4 | mini-SAS connector (8~11) |
| 5 | mini-SAS connector (0~3) | | |

Middle Plane Connectors

Figure 5-9. Middle Plane Connectors

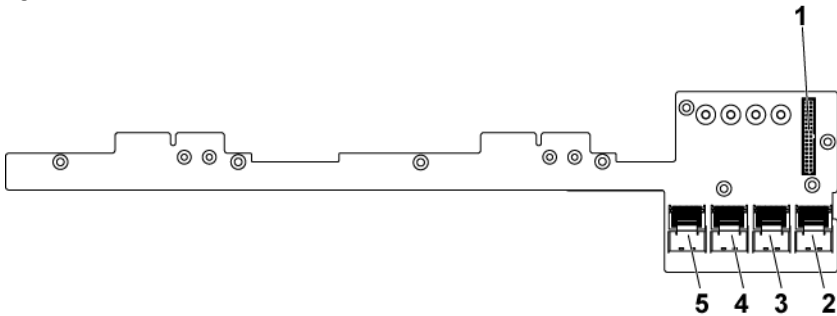

- | | | | |
|---|--|---|--|
| 1 | 2x17pin control connector for PDB1 | 2 | mini-SAS connector for system board 3 and 4 (hard drive 5 and 6) |
| 3 | mini-SAS connector for system board 3 and 4 (hard drive 1,2,3 and 4) | 4 | mini-SAS connector for system board 1 and 2 (hard drive 5 and 6) |

- 5 mini-SAS connector for system board 1 and 2 (hard drive 1,2,3 and 4)

Interposer Extender for 2U Node Connectors

Figure 5-10. Interposer Extender Connectors

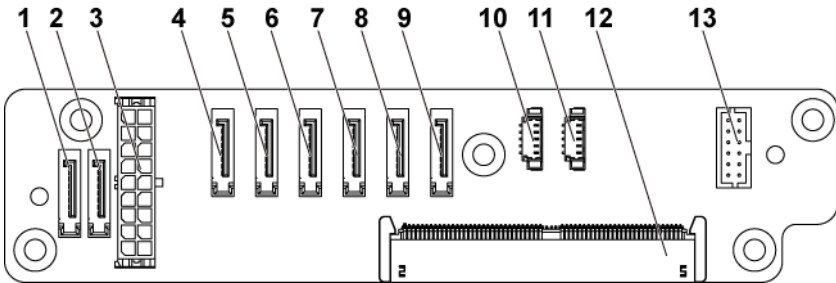

- | | | | |
|----|--------------------------------------|----|--------------------------------------|
| 1 | SATA2 and SAS connectors connector 6 | 2 | SATA2 and SAS connectors connector 7 |
| 3 | 2x9pin power connector | 4 | SATA2 and SAS connectors connector 5 |
| 5 | SATA2 and SAS connectors 4 | 6 | SATA2 and SAS connectors connector 3 |
| 7 | SATA2 and SAS connectors 2 | 8 | SATA2 and SAS connectors connector 1 |
| 9 | SATA2 and SAS connectors 0 | 10 | SGPIO Connector 2 |
| 11 | SGPIO Connector 1 | 12 | middle plane connector |
| 13 | 2x6pin control connector | | |

LSI 2008 SAS Mezzanine Card Connectors

Figure 5-11. LSI 2008 SAS Mezzanine Card Connectors

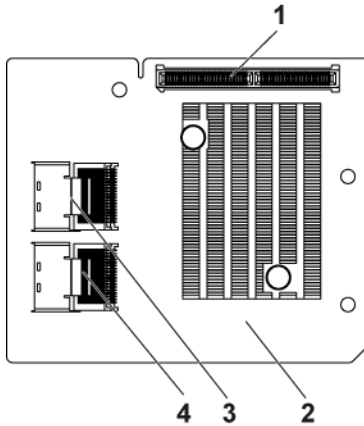

- | | | | |
|---|-------------------------------|---|-------------------------------|
| 1 | mezzanine card connector | 2 | LSI 2008 mezzanine card |
| 3 | mini-SAS connector (port 4-7) | 4 | mini-SAS connector (port 0-3) |

1GbE Mezzanine Card Connectors

Figure 5-12. 1GbE Mezzanine Card Connectors

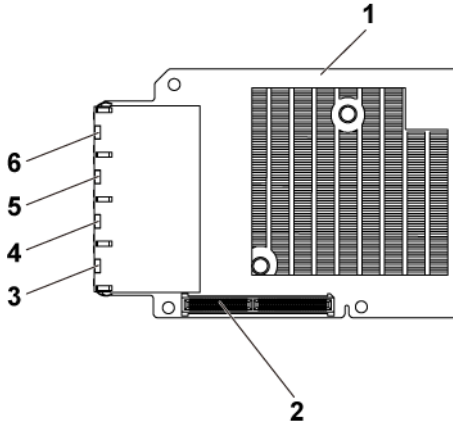

- | | | | |
|---|---------------------|---|--------------------------|
| 1 | 1GbE mezzanine card | 2 | mezzanine card connector |
| 3 | NIC connector 4 | 4 | NIC connector 3 |
| 5 | NIC connector 2 | 6 | NIC connector 1 |

10GbE Mezzanine Card Connectors

Figure 5-13. 10GbE Mezzanine Card Connectors

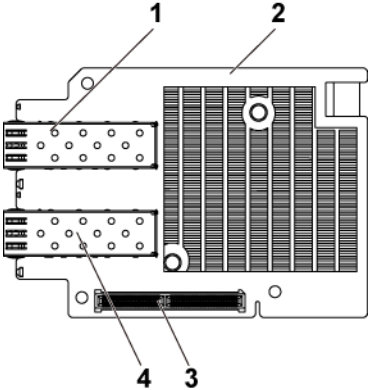

- 1 SFP + port 0
- 2 10GbE mezzanine card
- 3 mezzanine card connector
- 4 SFP + port 1

Power Distribution Board 1 Connectors

Figure 5-14. Power Distribution Board 1 Connectors

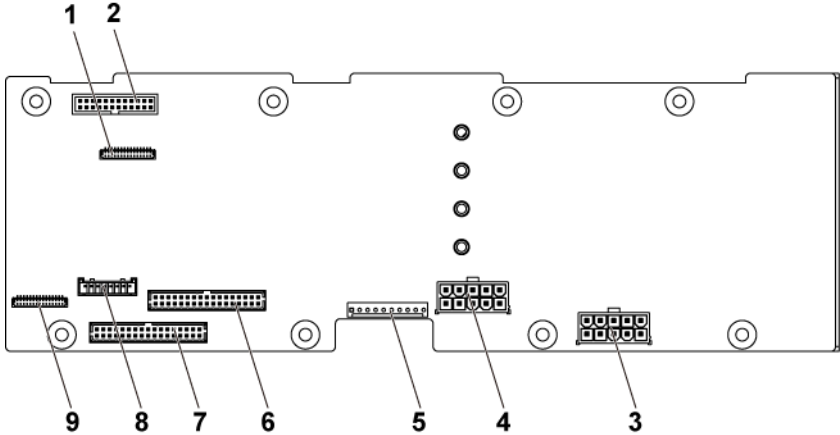

- | | | | |
|---|--|---|--|
| 1 | front panel connector for system board 1 and 2 | 2 | system fan connector |
| 3 | hard drive backplane power connector 1 | 4 | hard drive backplane power connector 2 |
| 5 | 1x10pin control connector | 6 | 2x17pin control connector for system board 2 and 4 |
| 7 | 2x17pin control connector for system board 1 and 3 | 8 | 1x8pin control connector to hard drive backplane |
| 9 | front panel connector for system board 3 and 4 | | |

Power Distribution Board 2 Connectors

Figure 5-15. Power Distribution Board 2 Connectors

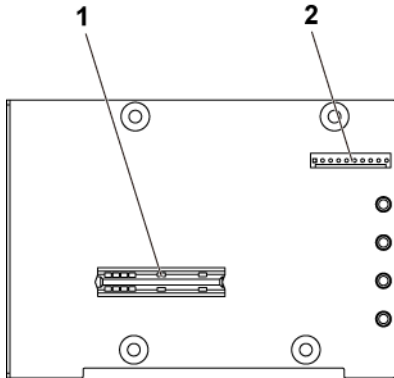

1 bridge card connector

2 1x10pin control connector

Sensor Board Connectors

Figure 5-16. Sensor Board Connectors

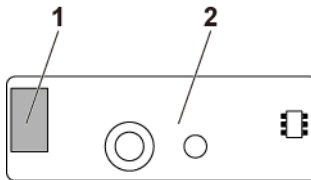

1 power connector

2 sensor board

Jumper Settings



CAUTION: Many repairs may only be done by a certified service technician. You should only perform troubleshooting and simple repairs as authorized in your product documentation, or as directed by the online or telephone service and support team. Damage due to servicing that is not authorized by Dell is not covered by your warranty. Read and follow the safety instructions that came with the product.

System Configuration Jumper Settings

The function of system configuration jumper installed on each system board is shown below:

Figure 5-17. System Configuration Jumpers

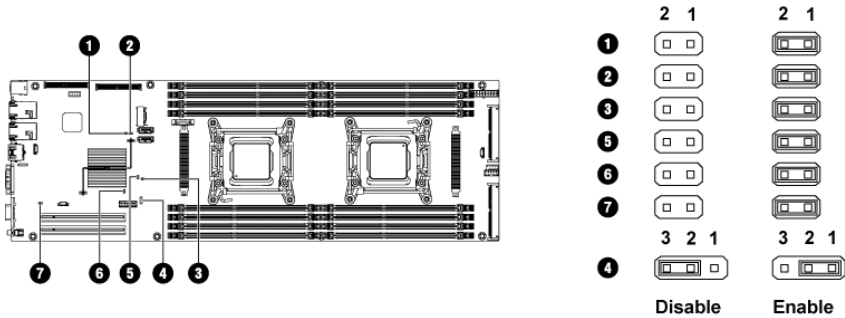

Table 5-1. System Configuration Jumper

Jumper	Function	Off	On
1	Service Mode	*Disable	Enable
2	NVRAM Clear	*Disable	Enable
3	BIOS Recovery	*Disable	Enable
5	ME Firmware Recovery	*Disable	Enable
6	MEDBG1	*Disable	Enable
7	Power Button Pass	*Disable	Enable
Jumper	Function	Pin1-2	Pin2-3
4	PWRD_EN	*Enable	Disable



NOTE: The * in the table of system configuration jumper describes the default status and the default state is not active state.

Direct Backplane Jumper Settings



CAUTION: Many repairs may only be done by a certified service technician. You should only perform troubleshooting and simple repairs as authorized in your product documentation, or as directed by the online or telephone service and support team. Damage due to servicing that is not authorized by Dell is not covered by your warranty. Read and follow the safety instructions that came with the product.

The function of jumpers installed on 3.5" HDD Direct Backplane and 2.5" HDD Direct Backplane is the same. Following is an example using the jumpers installed on 3.5" HDD Direct Backplane.

Figure 5-18. Jumper Installed on Direct Backplane

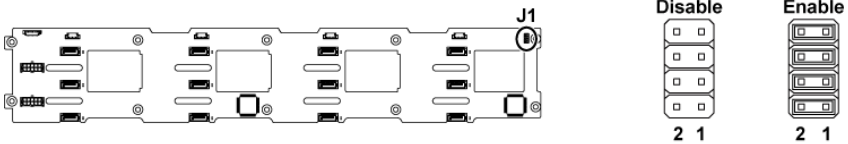

Table 5-2. Jumpers Installed on Direct Backplane

Jumper	Function	Off	On
SW1 (pin1-2)	Reserved	*Disable	Enable
SW2 (pin3-4)	Reserved	*Disable	Enable
SW3 (pin5-6)	SGPIO I ² C Select	*Disable	Enable
SW4 (pin7-8)	MFG Test	*Disable	Enable



NOTE: The * in the table of Direct Backplane jumper describes the default status and the default state is not active state.

Getting Help

Contacting Dell

For customers in the United States, call 800-WWW-DELL (800-999-3355).



NOTE: If you do not have an active Internet connection, you can find contact information on your purchase invoice, packing slip, bill, or Dell product catalog.

Dell provides several online and telephone-based support and service options. Availability varies by country and product, and some services may not be available in your area. To contact Dell for sales, technical support, or customer service issues:

- 1 Visit **support.dell.com**. Click your country/region at the bottom of the page. For a full listing of country/region, click **All**. Click **All Support** from **Support** menu.
- 2 Select the appropriate service or support link based on your need.
- 3 Choose the method of contacting Dell that is convenient for you.

Index

A

about your system, 12

B

back panel features, 24

backplane

installing direct BP, 255

removing 2.5-inch hard drive
backplane for expander
configuration, 257

removing direct BP, 250

backplane

installing 2.5-inch hard drive
backplane for expander
configuration, 265

backplane jumper settings, 309

batteries

troubleshooting, 285

battery (system)

replacing, 215

blank

hard drive, 133, 134

C

cable routing

LSI 9265-8i card (1U node),
170

LSI 9265-8i card (2U node),

177

power distribution board, 231,
244, 248, 272, 277

Riser card, 193

SAS mezzanine card (1U
node), 196

SAS mezzanine card (2U
node), 197

collecting system event log, 35,
47

contacting dell, 310

cooling fans

installing, 223

removing, 221

troubleshooting, 287

D

damaged systems

troubleshooting, 284

Dell

contacting, 310

drive blank

installing, 133, 134

removing, 133, 134

E

expander card

installing expander card for
2.5-inch hard drive
backplane, 264

- removing expander card from
 - 2.5-inch hard drive backplane, 264
- expansion card
 - troubleshooting, 292
- expansion card connector for 1U node
 - installing, 188
 - removing, 187
- expansion card connector for 2U node
 - installing, 192
 - removing, 189
- expansion card for 1U node
 - installing, 158
 - removing, 155
- expansion card for 2U node
 - installing, 163
 - removing, 159

F

- features and indicators
 - front panel, 13
- fresh air
 - support, 53
- front panel features, 13
- front panel installing, 268
- front panel removing, 266

H

- hard drive
 - installing hot-swap hard drive, 136

- removing hot-swap hard drive, 135
- troubleshooting, 290
- heat sink installing, 147
- heat sink removing, 144, 145
- heat sinks
 - installing, 147
 - removing, 144, 145

I

- indicator codes
 - AC power, 32
 - hard-drive indicator, 18
- NIC**, 29
- NIC (management port)**, 30
 - power and system board, 31
- indicators
 - back panel, 24
 - front panel, 13
- installing
 - 2.5-inch hard drive backplane
 - for expander configuration, 265
 - cooling fans, 223
 - direct BP, 255
 - expander card for 2.5-inch hard drive backplane, 264
 - expansion card connector for 1U node, 188
 - expansion card connector for 2U node, 192
 - expansion card for 1U node, 158
 - expansion card for 2U node,

- 163
- front panel, 268
- hard drive blank, 133, 134
- heat sink, 147
- hot-swap hard drive, 136
- interposer extender, 153
- interposer extender tray, 155
- LSI 9265-8i card for 1U node, 169
- LSI 9265-8i card for 2U node, 176
- mezzanine card (10GbE), 206
- mezzanine card (1GbE), 202
- middle planes, 241
- power distribution board, 229
- power supply, 140
- processor, 150
- SAS Mezzanine card, 195
- sensor board, 271
- system board, 218
- system board assembly, 143
- installing the LSI 9265-8i raid battery, 184
- installing the LSI 9265-8i raid battery assembly, 182
- Installing the mezzanine-card bridge board, 208
- interposer extender
 - installing, 153
 - removing, 152
- interposer extender tray
 - installing, 155
 - removing, 154

K

- keyboards
 - troubleshooting, 281

L

- LEDs
 - BMC heart beat, 34
- LSI 9265-8i card for 1U node
 - installing, 169
 - removing, 166
- LSI 9265-8i card for 2U node
 - installing, 176
 - removing, 172
- LSI 9265-8i raid battery assembly
 - removing, 181

M

- memory
 - troubleshooting, 288
- memory modules
 - removing, 211
- memory modules (DIMMs)
 - configuring, 209
- mezzanine card (10GbE)
 - installing, 206
 - removing, 203
- mezzanine card (1GbE)
 - installing, 202
 - removing, 200
- Micro SD card
 - socket location, 57
- middle planes

- installing, 241
- removing, 234

N

- NICs
 - troubleshooting, 282

P

- phone numbers, 310

POST

- accessing system features, 12

power distribution board

- installing, 229
- removing, 224

power supplies

- installing, 140
- removing, 139

processor

- installing, 150
- removing, 148

processors

- troubleshooting, 293

R

removing

- cooling fans, 221
- direct BP, 250
- expander card for 2.5-inch
 - hard drive backplane, 264
- expansion card connector for
 - 1U node, 187
- expansion card connector for

- 2U node, 189

- expansion card for 1U node,
 - 155

- expansion card for 2U node,
 - 159

- front panel, 266

- hard drive blank, 133, 134

- heat sink, 144, 145

- hot-swap hard drive, 135

- interposer extender, 152

- interposer extender tray, 154

- LSI 9265-8i card for 1U node,
 - 166

- LSI 9265-8i card for 2U node,
 - 172

- LSI 9265-8i raid battery
 - assembly, 181

- memory modules (DIMMs),
 - 211

- mezzanine card (1GbE), 200

- mezzanine card(10GbE), 203

- middle planes, 234

- power distribution board, 224

- power supply, 139

- processor, 148

- SAS Mezzanine card, 194

- sensor board, 270

- system board, 217

- system board assembly, 141,
 - 142

- removing the LSI 9265-8i RAID
 - battery, 183

- Removing the mezzanine-card
 - bridge board, 207

- replacing

system battery, 215

S

safety, 130

SAS controller daughter card
troubleshooting, 291

SAS Mezzanine card
installing, 195
removing, 194

SAS raid controller daughter card
troubleshooting, 291

startup
accessing system features, 12

support
contacting Dell, 310
fresh air, 53

system
closing, 220
opening, 219

system board
connectors, 295
installing, 218
jumper settings, 308
removing, 217

system board assembly
installing, 143
removing, 141, 142

system cooling
troubleshooting, 286

system features
accessing, 12

system setup
LAN configuration, 93
memory configuration, 76

PCI configuration, 81
power management, 69
processor configuration, 71
remote access configuration,
94
SATA configuration, 78
USB configuration, 88

T

telephone number, 310
troubleshooting
cooling fans, 287
damaged system, 284
expansion card, 292
external connections, 280
hard drive, 290
keyboard, 281
memory, 288
NIC, 282
processors, 293
SAS raid controller daughter
card, 291
sequence, 280
system battery, 285
system boot issues, 35, 47
system cooling, 286
wet system, 283

W

warranty, 53
wet system
troubleshooting, 283

